

# ***TMS370 Family***

## *Data Manual*





# ***TMS370 Family Data Manual***



**TEXAS  
INSTRUMENTS**

## IMPORTANT NOTICE

Texas Instruments (TI) reserves the right to make changes to or to discontinue any semiconductor product or service identified in this publication without notice. TI advises its customers to obtain the latest version of the relevant information to verify, before placing orders, that the information being relied upon is current.

TI warrants performance of its semiconductor products to current specifications in accordance with TI's standard warranty. Testing and other quality control techniques are utilized to the extent TI deems necessary to support this warranty. Unless mandated by government requirements, specific testing of all parameters of each device is not necessarily performed.

TI assumes no liability for TI applications assistance, customer product design, software performance, or infringement of patents or services described herein. Nor does TI warrant or represent that license, either express or implied, is granted under any patent right, copyright, mask work right, or other intellectual property right of TI covering or relating to any combination, machine, or process in which such semiconductor products or services might be or are used.

Texas Instruments products are not intended for use in life-support appliances, devices, or systems. Use of a TI product in such applications without the written consent of the appropriate TI officer is prohibited.

Throughout this manual, the term *TMS370* or *TMS370 family* refers to all members of the group.

## TRADEMARKS

Kermit is a registered trademark of Columbia University.

MS-DOS is a trademark of Microsoft Corp.

PC-DOS is a trademark of International Business Machines.

PROCOMM is a registered trademark of Datastorm Technologies Inc.

XDS is a trademark of Texas Instruments Incorporated.

VAX and VMS are trademarks of Digital Equipment Corp.

XTALK is a registered trademark of Microstuf Inc.

Introduction	1
Assembly Language Instruction Set	13
TMS370 Family Devices	2
Design Aids	14
CPU and Memory Organization	3
Development Support	15
System and Digital I/O Configuration	4
Electrical Specifications	16
Interrupts and System Reset	5
Customer Information	17
EEPROM Modules	6
Appendices	A-H
Timer 1 Module	7
Timer 2 Module	8
Serial Communications Interface (SCI) Port	9
Serial Peripheral Interface (SPI) Module	10
Analog-to-Digital Converter Module	11
TMS370 Programmable Acquisition and Control Timer	12





## Read This First

---

---

### *How to Use This Manual*

This document contains the following chapters:

**Chapter 1 Introduction**

**Chapter 2 Family Devices**

Presents the features of TMS370 family members including pinouts.

**Chapters 3–12**

Describe the operation and programming of each major function in the TMS370 architecture.

**Chapter 13 Instruction Set**

Describes the TMS370 addressing modes and each of the 73 instructions including samples and examples.

**Chapter 14 Design Aids**

Gives sample interface circuits and programming examples.

**Chapter 15 Development Support**

Describes the hardware and software design-development tools available for the TMS370 series.

**Chapter 16 Electrical Specifications**

Gives timing diagrams and electrical specifications.

**Chapter 17 Customer Information**

Gives packaging, numbering, and ordering information.

**Appendix A Peripheral File Map**

Gives reference tables for TMS370 control bits.

**Appendix B Block Diagrams**

Gives reference block diagrams with control bits.

**Appendix C Character Sets**

Give reference tables for the TMS370 character set.

**Appendix D Opcode/Instruction Cross Reference**

Gives an opcode-to-instruction cross reference of all 73 mnemonics and 246 opcodes of the TMS370 instruction set.

**Appendix E Instruction/Opcode Cross Reference**

Gives an instruction-to-opcode cross reference of all 73 mnemonics and 246 opcodes of the TMS370 instruction set and bus activity table.

**Appendix F PLCC to PGA Pinouts**

Gives PLCC to PGA Pinout (bottom view) for the TMS370 devices.

**Appendix G PACT.H**

Gives PACT.H macro used with PACT example programs.

**Appendix H Glossary**

**Appendix I Index**

***Related Documentation***

- 1) *TMS370 Family Assembly Language Tools User's Guide*, SPNU010.
- 2) *TMS370 Family XDS/22 User's Guide*, SPNU008A.
- 3) *TMS370 Family XDS/11 User's Guide*, SPNU015.
- 4) *TMS370 Application Board User's Guide*, SPNU013.
- 5) *TMS370/EEPROM Programmer's User's Guide*, SPNU011.
- 6) *TMS370Cx5x 8-Bit Microcontrollers Data Sheet*, SPNS010A.
- 7) *TMS370Cx10 8-Bit Microcontrollers Data Sheet*, SPNS012A.
- 8) *TMS370Cx32 8-Bit Microcontrollers Data Sheet*, SPNS015.
- 9) *Using the TMS370 A/D Converter Module Application Report*, SPNA005.
- 10) *Using the TMS370 SPI and SCI Modules Application Report*, SPNA006.
- 11) *Using the TMS370 Timer Modules Application Report*, SPNA008.
- 12) *Using the TMS370 EEPROM Module Application Report* (planned).

## Style and Symbol Conventions

This document uses the following conventions:

Symbol	Example	Description
(xxxxxx.n)	SPICTL.4	Bit location convention used in text, where 'xxxxxx' is the name of the register containing the bit and 'n' is the bit number (7 = msb, 0 = lsb).
(xx.n)	4A.0	Bit location convention used in figures, where 'xx' is the hexadecimal address of the peripheral register containing the bit and 'n' is the bit number (7 = msb, 0 = lsb).
h	1000h	Designates a number in the hexadecimal number system.
set		When used in reference to bits, means to write a logic 1 to the bit.
clear		When used in reference to bits, means to write a logic 0 to the bit.
P0n	P012	Hexadecimal Peripheral File (PF) address used in instructions accessing the PF. (i.e., P012 = P18)
Pn	P18	Decimal Peripheral File (PF) address used in instructions accessing the PF. (i.e., P18 = P012).
R0n	R010	Hexadecimal Register File (RF) address used in instructions accessing the RF. (i.e., R010 = R16)
Rn	R16	Decimal Register File (RF) address used in instructions accessing the RF. (i.e., R16 = R010)

- Program listings, program examples, interactive displays, filenames, and symbol names are shown in a special font. Examples use a bold version of the special font for emphasis. Here is a sample program listing:

```

7011 CAEF    0014 DJNZ  B,LOOP    ;loop until done
7013 FC     0015 POP   ST        ;restore stack to starting
              0016              ;position
0014 F9     0017 RTS          ;back to calling routine

```

- In syntax descriptions, the instruction, command, or directive is in a **bold face font** and parameters are in *italics*. Portions of a syntax that are in **bold face** should be entered as shown; portions of a syntax that are in *italics* describe the type of information that should be entered. Here is an example of a command syntax:

**CMPBIT** *name*

**CMPBIT** is the complement bit command and *name* indicates where a bit name must be entered.

- Braces ( { and } ) indicate a list. The symbol | (read as *or*) separates items within the list. Here's an example of a list:

```
{ + | - }
```

This provides two choices: + or -.

Unless the list is enclosed in square brackets, you must choose one item from the list.

- ❑ Some directives can have a varying number of parameters. For example, the `.byte` directive can have up to 100 parameters. The syntax for this directive is:

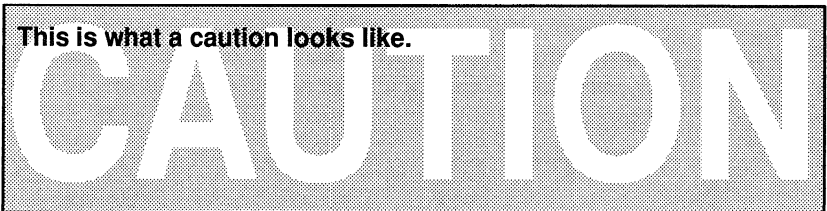
`.byte value1 [, ... , valuen]`

This syntax shows that `.byte` must have at least one value parameter, but you have the option of supplying additional value parameters, separated by commas.

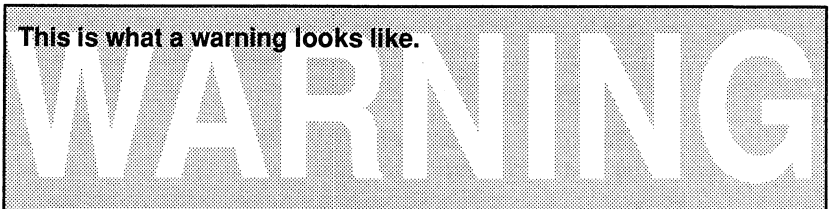
## Information about Cautions and Warnings

This book may contain cautions and warnings.

- ❑ A **caution** describes a situation that could potentially damage your software or equipment.



- ❑ A **warning** describes a situation that could potentially cause harm to you.



The information in a caution or a warning is provided for your protection. Please read each caution and warning carefully.



## Updates Added to This Manual

This manual replaces the previous *TMS370 Family Data Manual*, literature number SPNS014. Additional information has been added or modified to the following sections:

- |   |  |                |
|---|--|----------------|
| ☐ | TMS370Cx1x Devices – New configurations added: |                |
|   |  | <b>Section</b> |
| ■ | Family Features .....                          | 1.1            |
| ■ | Summary .....                                  | 2.1            |
| ■ | TMS370Cx1x Clockout Timing .....               | 16.1           |
| ☐ | TMS370Cx5x Devices – New configurations added: |                |
|   |  | <b>Section</b> |
| ■ | Family Features .....                          | 1.1            |
| ■ | Summary .....                                  | 2.1            |
| ■ | Memory Maps .....                              | 3.4            |
| ☐ | TMS370Cx3x Devices – New configurations added: |                |
|   |  | <b>Section</b> |
| ■ | Family Features .....                          | 1.1            |
| ■ | Architectural Overview .....                   | 1.2            |
| ■ | Summary .....                                  | 2.1            |
| ■ | Features .....                                 | 2.2            |
| ■ | TMS370Cx3x Pinout .....                        | 2.3.3          |
| ■ | TMS370Cx3x Pin Description .....               | 2.3.4          |
| ■ | Peripheral File Address Map .....              | 3.3.2          |
| ■ | Vector Address Map .....                       | 3.3.4          |
| ■ | Memory Operating Modes .....                   | 3.4            |
| ■ | Privilege Mode Bits .....                      | 4.1.1          |
| ■ | Module Interrupt Priority .....                | 5.1.1          |
| ■ | Interrupt Vector Sources .....                 | 5.1.1          |
| ■ | PACT Module .....                              | Chapter 12     |
| ■ | PACT Programming Examples .....                | 14.5           |
| ■ | PACT XDS/22 (in circuit emulator) .....        | 15.3           |
| ■ | TMS370Cx3x Electrical Specification .....      | 16.2           |
| ■ | Mechanical Package Information .....           | 17.2           |
| ■ | PLCC to PGA Pinout .....                       | Appendix F     |
| ■ | PACT Macros (for programming examples) ....    | Appendix G     |
| ☐ | New Modules                                    |                |
|   |  | <b>Section</b> |
| ■ | EPROM Module .....                             | 6.3            |
| ■ | PACT Module .....                              | Chapter 12     |

□	Bit Descriptions enhanced/modified	
		<b>Section</b>
■	Oscillator Power Bit .....	4.1.5.1
■	Array Program (Data EEPROM) .....	6.1.1.2
■	Timer 2 Edge Detect Bits .....	8.3.3
■	Flags Affected by Software Reset .....	9.3.2
□	New Information	
		<b>Section</b>
■	Programmers Model Figure .....	3.1
■	Program Memory Options .....	3.3.4
■	Oscillator Fault Operation .....	4.1.2
■	Using Interrupts to Exit from Powerdown Modes ....	4.1.4.3
■	Reset Circuit with Low Voltage Detect .....	5.2.2
■	Timer 1 Compare Register Formula .....	7.2.7
■	Timer 2 Compare Register Formula .....	8.2.8
■	Common SCI Baud Rates .....	9.2.3
■	Common SPI Bit Rates .....	10.2.3
■	PACT XDS/22 System .....	15.3
■	XDS/11 System .....	15.4
■	Design Kit .....	15.6
■	FFE Support of ROM Devices .....	15.7
■	Block Diagrams with Peripheral Files .....	Appendix B
■	Instruction Bus Activity Table .....	Appendix E
■	PLCC to PGA Pinouts .....	Appendix F
□	Updated Information	
		<b>Section</b>
■	XDS System Configuration Requirements .....	15.5
■	Standard Debugger Interface (SDI) .....	15.7
■	TMS370Cx1x Clockout Timing .....	16.1
■	Mechanical Package Information .....	17.2
■	Device Numbering Convention .....	17.3.2
■	Device Symbolization .....	17.3.3
■	Development Tool Support Ordering Information ....	17.4

# Contents

---

---

---

<b>1</b>	<b>Introduction</b>	<b>1-1</b>
1.1	TMS370 Overview	1-2
1.2	TMS370 Architecture Overview	1-5
1.3	Manual Organization	1-11
1.4	Symbols and Conventions	1-12
1.5	Applicable Documents	1-13
<b>2</b>	<b>TMS370 Family Devices</b>	<b>2-1</b>
2.1	Summary and Device Comparison	2-4
2.2	TMS370 Features	2-6
2.2.1	TMS370Cx1x Features	2-7
2.2.2	TMS370Cx3x Features	2-7
2.2.3	TMS370Cx5x Features	2-8
2.3	TMS370 Family Pinouts/Pin Descriptions	2-9
2.3.1	TMS370Cx1x Pinouts	2-9
2.3.2	TMS370Cx1x Pin Descriptions	2-10
2.3.3	TMS370Cx3x Pinouts	2-11
2.3.4	TMS370Cx3x Pin Descriptions	2-12
2.3.5	TMS370Cx5x Pinouts	2-14
2.3.6	TMS370Cx5x Pin Descriptions	2-15
<b>3</b>	<b>CPU and Memory Organization</b>	<b>3-1</b>
3.1	CPU/Register File Interaction	3-2
3.2	CPU Registers	3-3
3.2.1	Stack Pointer (SP)	3-3
3.2.2	Status Register (ST)	3-5
3.2.3	Program Counter	3-7
3.3	Memory Map	3-8
3.3.1	Register File	3-8
3.3.2	Peripheral File	3-10
3.3.3	Data EEPROM Modules	3-12
3.3.4	Program Memory	3-12
3.4	Memory Operating Modes	3-15

3.4.1	Microcomputer Mode Single-Chip .....	3-16
3.4.2	Microcomputer Mode with External Expansion (All devices with Bus Expansion and Internal Program Memory) .....	3-17
3.4.3	Microprocessor Mode without Internal Memory (Bus Expansion Devices Only) .....	3-21
3.4.4	Microprocessor Mode with Internal Program Memory (Bus Expansion Devices Only) .....	3-22
3.4.5	Memory Mode Summary .....	3-24
<b>4</b>	<b>System and Digital I/O Configuration .....</b>	<b>4-1</b>
4.1	System Configuration .....	4-2
4.1.1	Privilege Mode .....	4-2
4.1.2	Oscillator Fault .....	4-3
4.1.3	Automatic Wait States .....	4-4
4.1.4	Powerdown and Idle Modes .....	4-6
4.1.5	System Control Registers .....	4-10
4.2	Digital I/O Configuration .....	4-15
4.2.1	Microprocessor Mode .....	4-21
4.2.2	Microcomputer Mode .....	4-21
<b>5</b>	<b>Interrupts and System Reset .....</b>	<b>5-1</b>
5.1	Interrupts .....	5-2
5.1.1	Interrupt Operation .....	5-2
5.1.2	External Interrupts .....	5-7
5.1.3	Interrupt Control Registers .....	5-10
5.1.4	Multiple Interrupt Servicing .....	5-13
5.2	Resets .....	5-14
5.2.1	Simple Reset Circuitry .....	5-15
5.2.2	Reset Circuitry with Low-voltage Detection .....	5-16
<b>6</b>	<b>EPROM and EEPROM Modules .....</b>	<b>6-1</b>
6.1	Data EEPROM Module .....	6-2
6.1.1	Control Registers .....	6-2
6.1.2	Programming the Data EEPROM .....	6-5
6.1.3	Write Protection Register Operation .....	6-8
6.2	Program EEPROM Module .....	6-9
6.2.1	Program EEPROM Control Register (PEECTL) .....	6-10
6.2.2	Programming the Program EEPROM .....	6-11
6.2.3	Write Protection of Program EEPROM .....	6-11
6.3	Program EPROM Modules .....	6-12
6.3.1	Program EPROM Control Register (EPCTL) .....	6-13
6.3.2	Programming the Program EPROM .....	6-14



6.3.3	Write Protection of Program EPROM .....	6-16
<b>7</b>	<b>Timer 1 Module .....</b>	<b>7-1</b>
7.1	Timer 1 Overview .....	7-2
7.1.1	Introduction .....	7-2
7.1.2	Major Components .....	7-3
7.1.3	Operating Modes Overview .....	7-6
7.2	Timer 1 Operation .....	7-7
7.2.1	General Purpose Timer Operating Modes .....	7-7
7.2.2	Clock Prescaler/External Clock Source .....	7-11
7.2.3	Edge Detection .....	7-13
7.2.4	General Purpose Counter .....	7-14
7.2.5	Compare Register .....	7-15
7.2.6	Capture/Compare Register .....	7-16
7.2.7	Timer 1: Compare Register Formula .....	7-17
7.2.8	Interrupts .....	7-18
7.3	Watchdog Timer .....	7-19
7.3.1	Watchdog Counter .....	7-19
7.3.2	Power-up Reset .....	7-21
7.3.3	Reset Frequency .....	7-22
7.3.4	Overflow Flag .....	7-22
7.4	Low-Power Modes .....	7-23
7.4.1	Halt .....	7-23
7.4.2	Standby .....	7-23
7.5	Timer 1 Control Registers .....	7-24
7.5.1	Timer 1 Counter Control Register 1 .....	7-26
7.5.2	Timer 1 Counter Control Register 2 .....	7-28
7.5.3	Timer 1 Counter Control Register 3 .....	7-30
7.5.4	Timer 1 Counter Control Register 4 .....	7-32
7.5.5	Timer 1 Port Control Registers .....	7-34
7.5.6	Timer 1 Interrupt Priority Control Register .....	7-37
<b>8</b>	<b>Timer 2 Module .....</b>	<b>8-1</b>
8.1	Timer 2 Overview .....	8-2
8.2	Timer 2 Operation .....	8-5
8.2.1	Operation Modes .....	8-5
8.2.2	Clock Sources .....	8-8
8.2.3	Timer 2 Edge Detection Circuitry .....	8-9
8.2.4	16-Bit Resettable Up Counter .....	8-10
8.2.5	Compare Register .....	8-11
8.2.6	Capture Register (Dual Capture Mode Only) .....	8-11

8.2.7	Capture/Compare Register .....	8-12
8.2.8	Timer 2: Compare Register Formula .....	8-13
8.2.9	Timer 2 I/O Pin Functions .....	8-13
8.2.10	Timer 2 Interrupts .....	8-14
8.2.11	Power-Down Modes .....	8-15
8.3	Timer 2 Control Registers .....	8-16
8.3.1	Timer 2 Control Register 1 .....	8-18
8.3.2	Timer 2 Control Register 2 .....	8-19
8.3.3	Timer 2 Control Register 3 .....	8-21
8.3.4	Timer 2 Port Control Registers .....	8-23
8.3.5	Timer 2 Interrupt Priority Control Register .....	8-26
<b>9</b>	<b>Serial Communications Interface (SCI) Port .....</b>	<b>9-1</b>
9.1	SCI Overview .....	9-2
9.1.1	Physical Description .....	9-2
9.1.2	SCI Features .....	9-3
9.1.3	SCI Formats and Operation Modes .....	9-4
9.1.4	SCI Control Registers .....	9-5
9.2	SCI Operation .....	9-6
9.2.1	SCI Programmable Data Format .....	9-6
9.2.2	SCI Port Interrupts .....	9-6
9.2.3	SCI Clock Sources .....	9-7
9.2.4	SCI Communications Modes .....	9-8
9.2.5	SCI Multiprocessor Communications .....	9-11
9.2.6	SCI Initialization Examples .....	9-15
9.3	SCI Control Registers .....	9-19
9.3.1	Communication Control Register (SCICCR) .....	9-20
9.3.2	Control Register (SCICTL) .....	9-22
9.3.3	Baud Select Registers (BAUD MSB and BAUD LSB) .....	9-24
9.3.4	Transmitter Interrupt Control and Status Register (TXCTL) .....	9-25
9.3.5	Receiver Interrupt Control and Status Register (RXCTL) .....	9-26
9.3.6	Receiver Data Buffer Register (RXBUF) .....	9-28
9.3.7	Transmit Data Buffer Register (TXBUF) .....	9-28
9.3.8	Port Control Register 1 (SCIPC1) .....	9-29
9.3.9	Port Control Register 2 (SCIPC2) .....	9-30
9.3.10	Priority Control Register (SCIPRI) .....	9-31
<b>10</b>	<b>Serial Peripheral Interface (SPI) Module .....</b>	<b>10-1</b>
10.1	Serial Peripheral Interface (SPI) Module Overview .....	10-2
10.1.1	Physical Description .....	10-2
10.1.2	SPI Control Registers .....	10-4

10.2	SPI Operation .....	10-5
10.2.1	SPI Data Format .....	10-5
10.2.2	SPI Interrupts .....	10-6
10.2.3	SPI Clock Sources .....	10-7
10.2.4	SPI Operation Modes .....	10-8
10.2.5	Initialization .....	10-9
10.2.6	SPI Example .....	10-10
10.3	SPI Control Registers .....	10-11
10.3.1	SPI Configuration Control Register .....	10-12
10.3.2	SPI Operation Control Register .....	10-14
10.3.3	Serial Input Buffer (SPIBUF) .....	10-15
10.3.4	Serial Data Register (SPIDAT) .....	10-16
10.3.5	Port Control Registers .....	10-17
10.3.6	SPI Interrupt Priority Control Register (SPIPRI) .....	10-20
<b>11</b>	<b>Analog-to-Digital Converter Module .....</b>	<b>11-1</b>
11.1	Analog-to-Digital Converter (A/D) Overview .....	11-2
11.1.1	A/D Physical Description .....	11-2
11.1.2	A/D Control Registers .....	11-4
11.2	A/D Operation .....	11-5
11.2.1	Input/Output Pins .....	11-5
11.2.2	A/D Sampling Time .....	11-5
11.2.3	A/D Conversion .....	11-5
11.2.4	A/D Interrupts .....	11-6
11.2.5	A/D Programming Considerations .....	11-7
11.3	A/D Example Program .....	11-8
11.4	A/D Control Registers .....	11-10
11.4.1	Analog Control Register (ADCTL) .....	11-11
11.4.2	Analog Status and Interrupt Register, (ADSTAT) .....	11-13
11.4.3	Analog Conversion Data Register (ADDATA) .....	11-14
11.4.4	Analog Port E Data Input Register (ADIN) .....	11-15
11.4.5	Analog Port E Input Enable Register (ADENA) .....	11-16
11.4.6	Analog Interrupt Priority Register (ADPRI) .....	11-17
<b>12</b>	<b>TMS370 Programmable Acquisition and Control Timer .....</b>	<b>12-1</b>
12.1	Features .....	12-2
12.2	Overview .....	12-3
12.3	Time Base .....	12-4
12.4	Inputs .....	12-5
12.5	Memory Organization .....	12-6
12.6	Control and Outputs .....	12-8

12.6.1	Standard Compare Command	12-9
12.6.2	Virtual Timers	12-10
12.6.3	Double Event Compare Command	12-11
12.6.4	Offset Timer Definition-Time From Last Event	12-12
12.6.5	Conditional Compare Command	12-13
12.6.6	Baud Rate Timer Definition	12-13
12.7	Architecture	12-14
12.7.1	Hardware Pin Allocation	12-14
12.7.2	RAM Organization	12-14
12.7.3	Command/Definition File Format	12-16
12.7.4	Time Slot Availability	12-16
12.7.5	Timer Prescaler	12-18
12.8	Input Capture Functions	12-19
12.9	Command/Definition Area	12-21
12.9.2	Command/Definition Summary	12-21
12.10	Interrupts	12-29
12.11	Watchdog	12-32
12.12	Serial Communication Interface (SCI)	12-33
12.13	PWM Example	12-34
12.13.1	Defining the Command/Definition Area	12-34
12.13.2	Copying the Command/Definition Area to Dual-Port RAM	12-34
12.13.3	Initializing the PACT Peripheral Frame	12-35
12.14	PACT Block Diagram	12-37
12.15	Peripheral Frame Control Registers	12-38
12.15.1	Setup Control Register	12-40
12.15.2	Command/Definition Area Start Register	12-42
12.15.3	Command/Definition Area End Register	12-43
12.15.4	Buffer Pointer Register	12-44
12.15.5	PACT-SCI Control Register	12-45
12.15.6	PACT-SCI RX Data Register	12-46
12.15.7	PACT-SCI TX Data Register	12-46
12.15.8	Output Pin 1 – 8 State Register	12-47
12.15.9	Command/Definition Entry Flags Register	12-48
12.15.10	Setup CP Control Register 1	12-49
12.15.11	Setup CP Control Register 2	12-51
12.15.12	Setup CP Control Register 3	12-53
12.15.13	CP Input Control Register	12-55
12.15.14	Global Function Control Register	12-57
<b>13</b>	<b>Assembly Language Instruction Set</b>	<b>13-1</b>
13.1	Instruction Operation	13-2



13.2	Addressing Modes .....	13-3
13.2.1	General Addressing Modes .....	13-4
13.2.2	Extended Addressing Modes .....	13-10
13.2.3	Additional Addressing Modes .....	13-17
13.2.4	Status Register .....	13-17
13.3	Instruction Set Overview .....	13-18
13.4	Instruction Set Descriptions .....	13-30
<b>14</b>	<b>Design Aids .....</b>	<b>14-1</b>
14.1	Microcomputer Interface Example .....	14-2
14.1.1	Read Cycle Timing .....	14-6
14.1.2	Write Cycle Timing .....	14-10
14.1.3	Design Options .....	14-11
14.1.4	Software Examples For Bank Switching .....	14-13
14.2	Programming with the TMS370 Family .....	14-16
14.3	Serial Communications .....	14-20
14.3.1	SPI Port Interfacing .....	14-20
14.3.2	SCI Port Interfacing .....	14-21
14.4	Analog/Digital Converter .....	14-24
14.5	PACT Module .....	14-25
14.5.1	Time After Event Example .....	14-25
14.5.2	Double Event Command Example .....	14-29
14.5.3	PACT SCI Example .....	14-31
14.6	Sample Routines .....	14-33
14.6.1	T1PWM Pin Setup .....	14-33
14.6.2	Clear RAM .....	14-34
14.6.3	RAM Self Test .....	14-35
14.6.4	ROM Checksum .....	14-36
14.6.5	Binary-to-BCD Conversion .....	14-37
14.6.6	BCD-To-Binary Conversion .....	14-38
14.6.7	BCD String Addition .....	14-39
14.6.8	Fast Parity .....	14-40
14.6.9	Bubble Sort .....	14-41
14.6.10	Table Search .....	14-42
14.6.11	16-by-16 (32-Bit) Multiplication .....	14-43
14.6.12	Keyboard Scan .....	14-44
14.6.13	Divide 1 .....	14-46
14.6.14	Divide Instruction 2 .....	14-47
<b>15</b>	<b>Development Support .....</b>	<b>15-1</b>
15.1	The Assembly Language Tools .....	15-3

15.1.1	The Assembler .....	15-4
15.1.2	The Linker .....	15-5
15.1.3	The Archiver .....	15-7
15.1.4	Code Conversion Utility .....	15-7
15.2	The XDS/22 System .....	15-8
15.3	The PACT XDS/22 System .....	15-9
15.4	The XDS/11 System .....	15-10
15.5	XDS System Configuration Requirements .....	15-11
15.6	Design Kit .....	15-12
15.6.1	Modes of Operation .....	15-12
15.7	Standard Debugger Interface .....	15-14
15.7.2	Breakpoint/Trace/Timing Functions .....	15-17
15.8	XDS System Operating Considerations .....	15-24
15.8.1	Mode Control Pin .....	15-24
15.8.2	Reset .....	15-24
15.8.3	Clock In .....	15-24
15.9	The TI EEPROM Programmer .....	15-25
15.10	Form Factor Emulators .....	15-27
<b>16</b>	<b>Electrical Specifications .....</b>	<b>16-1</b>
16.1	TMS370Cx1x Specifications .....	16-2
16.1.1	Timing Parameter Symbology .....	16-6
16.1.2	Parameter Measurement Information .....	16-6
16.2	TMS370Cx3x Specifications .....	16-11
16.2.1	Timing Parameter Symbology .....	16-15
16.2.2	Parameter Measurement Information .....	16-15
16.2.3	A/D Converter .....	16-18
16.3	TMS370Cx5x Specifications .....	16-21
16.3.1	Timing Parameter Symbology .....	16-26
16.3.2	Parameter Measurement Information .....	16-26
16.3.3	A/D Converter .....	16-36
<b>17</b>	<b>Customer Information .....</b>	<b>17-1</b>
17.1	Mask ROM Prototype and Production Flow .....	17-2
17.2	Mechanical Package Information .....	17-6
17.3	TMS370 Family Numbering and Symbol Conventions .....	17-10
17.3.1	Device Prefix Designators .....	17-10
17.3.2	Device Numbering Convention .....	17-11
17.3.3	Device Symbols .....	17-11
17.4	Development Support Tools Ordering Information .....	17-15
17.4.1	TMS370 Macro Assembler, Linker, and Utilities .....	17-15

17.4.2	TMS370 Design Kit .....	17-15
17.4.3	TMS370 EEPROM Programmer .....	17-15
17.4.4	TMS370 XDS Systems .....	17-15
17.4.5	Complete TMS370 Development System .....	17-16
17.4.6	XDS Upgrade .....	17-16
17.4.7	XDS Target Connectors .....	17-16
<b>A</b>	<b>Peripheral File Map .....</b>	<b>A-1</b>
<b>B</b>	<b>Block Diagrams .....</b>	<b>B-1</b>
<b>C</b>	<b>Character Sets .....</b>	<b>C-1</b>
<b>D</b>	<b>Opcode/Instruction Cross Reference .....</b>	<b>D-1</b>
<b>E</b>	<b>Instruction/Opcode Cross Reference &amp; Bus Activity Table .....</b>	<b>E-1</b>
E.1	Instruction/Opcode Cross Reference .....	E-2
E.2	Bus Activity Tables .....	E-4
E.2.1	Possible Bus Cycles .....	E-5
E.2.2	Internal Cycles .....	E-5
<b>F</b>	<b>PLCC to PGA Pinouts .....</b>	<b>F-1</b>
<b>G</b>	<b>PACT.H .....</b>	<b>G-1</b>
G.1	General Comments .....	G-2
G.1.1	Addressing Commands and Definitions in Dual-Port RAM .....	G-2
G.1.2	Defining Output Pins .....	G-3
G.1.3	Defining Actions .....	G-3
G.2	Comments for Specific Macros .....	G-4
G.2.1	Standard Compare Command .....	G-4
G.2.2	Conditional Compare Command .....	G-4
G.2.3	Virtual Timer Definition .....	G-4
G.2.4	Baud Rate Timer Definition .....	G-4
G.3	PACT.H Macros .....	G-5
<b>H</b>	<b>Glossary .....</b>	<b>H-1</b>

# Figures

---

---

1-1	TMS370Cx1x Block Diagram .....	1-5
1-2	TMS370Cx3x Block Diagram .....	1-6
1-3	TMS370Cx5x Block Diagram .....	1-7
2-1	Pinouts for TMS370Cx1x .....	2-9
2-2	Pinout for TMS370Cx3x .....	2-11
2-3	Pinouts for TMS370Cx5x .....	2-14
3-1	Programmer's Model .....	3-2
3-2	Stack Example .....	3-3
3-3	Program Counter After Reset .....	3-7
3-4	TMS370 Memory Map .....	3-8
3-5	Register File Addresses .....	3-9
3-6	Microcomputer, Single Chip Mode .....	3-17
3-7	Microcomputer Mode with Function A Expansion .....	3-19
3-8	Microcomputer Mode with Function B Expansion .....	3-20
3-9	Microprocessor Mode without Internal Memory .....	3-21
3-10	Microprocessor Mode with Internal Program Memory .....	3-23
3-11	Memory Operating Modes .....	3-25
4-1	System Configuration and Control Registers .....	4-2
4-2	Correct Method to Enter Halt Mode .....	4-8
4-3	Improper Method to Enter Halt Mode .....	4-9
4-4	Digital Port Control Registers .....	4-15
4-5	Port Control Register Operation .....	4-16
4-6	Port Configuration Registers Set-Up .....	4-17
4-7	System Interface Example .....	4-22
5-1	Interrupt Control .....	5-3
5-2	Peripheral File Frame 1 – External Interrupt Control Registers .....	5-7
5-3	Interrupt 1 Block Diagram .....	5-9
5-4	Interrupts 2 and 3 Block Diagram .....	5-9
5-5	Typical Reset Circuit .....	5-16

---

5-6	Typical Reset Circuit with Low-voltage Detection .....	5-17
6-1	Write Protection Bits .....	6-3
6-2	EEPROM Programming Example .....	6-6
6-3	EPROM Programming Operation .....	6-15
7-1	Timer 1 Block Diagram .....	7-4
7-2	Dual Compare Mode .....	7-9
7-3	Capture/Compare Mode .....	7-10
7-4	Timer 1 System Clock Prescaler .....	7-11
7-5	Pulse Accumulation .....	7-13
7-6	Watchdog Timer .....	7-19
7-7	Peripheral File Frame 4 – Timer 1 Control Registers .....	7-25
8-1	Timer 2 Block Diagram .....	8-3
8-2	Dual Compare Mode .....	8-6
8-3	Dual Capture Mode .....	8-7
8-4	Timer 2 Clock Sources .....	8-9
9-1	SCI Block Diagram .....	9-3
9-2	SCI Data Frame Formats .....	9-6
9-3	Asynchronous Communication Format .....	9-9
9-4	Isosynchronous Communication Format .....	9-9
9-5	SCI RX Signals in Communication Modes .....	9-10
9-6	SCI TX Signals in Communications Modes .....	9-11
9-7	Idle Line Multiprocessor Communication Format .....	9-13
9-8	Double-Buffered WUT and TXSHF .....	9-14
9-9	Address Bit Multiprocessor Communication Format .....	9-15
10-1	SPI Block Diagram .....	10-3
10-2	SPI Master/Slave Connection .....	10-5
10-3	SPI Control Registers .....	10-11
11-1	Analog-to-Digital Converter Block Diagram .....	11-3
11-2	Ratiometric Conversion Example .....	11-6
12-1	PACT Overview .....	12-3
12-2	Time Base Block Diagram .....	12-4
12-3	Input Capture Block Diagram .....	12-5
12-4	Dual-Port RAM Organization .....	12-6
12-5	RAM Organization .....	12-7
12-6	Output Control Section .....	12-8

12-7	Standard Compare Command	12-9
12-8	Virtual Timer Implementation	12-11
12-9	Mode A and B RAM Organization	12-16
12-10	Prescaler Circuit	12-18
12-11	PACT Block Diagram	12-37
13-1	Implied Addressing Mode	13-4
13-2	Register Addressing Mode	13-5
13-3	Peripheral Addressing Mode	13-6
13-4	Immediate Addressing Mode	13-7
13-5	Program Counter Relative Addressing Mode	13-8
13-6	Stack Pointer Relative Addressing Mode	13-9
13-7	Absolute Direct Addressing Mode	13-11
13-8	Relative Direct Addressing Mode	13-11
13-9	Absolute Indexed Addressing Mode	13-12
13-10	Relative Indexed Addressing Mode	13-13
13-11	Absolute Indirect Addressing Mode	13-14
13-12	Relative Indirect Addressing Mode	13-14
13-13	Absolute Offset Indirect Addressing Mode	13-15
13-14	Relative Offset Indirect Addressing Mode	13-16
13-15	Status Register (ST)	13-17
14-1	Microcomputer Interface Example	14-3
14-2	Valid Address-To-Data Read Timing	14-6
14-3	Chip Select Low To Data Read Timing	14-7
14-4	Chip Select High To Next Data Bus Drive Timing	14-8
14-5	Read Data Hold After Chip Select High Timing	14-9
14-6	Write Data Setup Timing	14-10
14-7	Write Data Hold After Chip Select High	14-11
14-8	Master/Slave SPI Interface Example	14-20
14-9	SCI/RS-232 Interface Example	14-21
14-10	Auto Baud rate Waveform	14-22
14-11	A/D Converter Sample Applications	14-24
14-12	Time After Event – Example Waveforms	14-25
14-13	Double Event – Example Waveforms	14-29
14-14	Keyboard Scan Values	14-44
15-1	Software Development Flow	15-3

---

15-2	Linker Output Generation .....	15-6
15-3	Typical XDS System Configuration .....	15-11
15-4	XDS Debugger Top Level Screen .....	15-15
15-5	BTT Operation (XDS/22 Systems Only) .....	15-19
15-6	BTT Screen (XDS/22 Systems Only) .....	15-20
15-7	Trace Sample Screen (XDS/22 Systems Only) .....	15-22
15-8	Typical EEPROM/VEEPROM Programmer Configuration .....	15-25
16-1	Recommended Crystal/Clock Connections .....	16-5
16-2	Typical Output Load Circuit .....	16-5
16-3	External Clock Timing .....	16-7
16-4	CLKOUT Timing .....	16-7
16-5	Switching Time Measurement Points .....	16-8
16-6	SPI Master External Timing .....	16-9
16-7	SPI Slave External Timing .....	16-10
16-8	Recommended Crystal/Clock Connections .....	16-14
16-9	Typical Output Load Circuit .....	16-14
16-10	External Clock Timing .....	16-16
16-11	CLKOUT Timing .....	16-16
16-12	Switching Time Measurement Points .....	16-17
16-13	Analog Timing .....	16-20
16-14	Recommended Crystal/Clock Connections .....	16-25
16-15	Typical Output Load Circuit .....	16-25
16-16	External Clock Timing .....	16-27
16-17	Switching Time Measurement Points .....	16-27
16-18	External Read Timing .....	16-30
16-19	External Write Timing .....	16-31
16-20	SPI Master External Timing .....	16-32
16-21	SPI Slave External Timing .....	16-33
16-22	SCI Isosynchronous Mode Timing Diagram for Internal Clock .....	16-34
16-23	SCI Isosynchronous Mode Timing Diagram for External Clock .....	16-35
16-24	Analog Timing .....	16-38
17-1	Prototype and Production Flow .....	17-2
17-2	28-Pin Plastic Dual-Inline Package, 100-MIL Pin Spacing (Type N Package Suffix) .....	17-7
17-3	Plastic-Leaded Chip Carrier Package (Type FN Package Suffix) .....	17-8

17-4	Ceramic Leaded Chip Carrier Package (FJ suffix)	17-9
17-5	Development Flowchart	17-10
17-6	TMS370 Family Nomenclature	17-11
17-7	TI Standard Symbolization for Mask ROM Device in 28-Pin N-Type Package	17-12
17-8	TI Standard Symbolization for Mask ROM Device in 28-Pin FN Type Package	17-12
17-9	TI Standard Symbolization for Mask ROM Device in 44-Pin FN Type Package	17-12
17-10	TI Standard Symbolization for Mask ROM Device in 68-Pin FN Type Package	17-12
17-11	TI Standard Symbolization for Program EEPROM Device in N-Type Package	17-13
17-12	TI Standard Symbolization for EEPROM Device in FN-Type Package	17-13
17-13	TI Standard Symbolization for Program EPROM Device in FJ-Type Package (68-Pin and 44-Pin)	17-14
B-1	Interrupt 1 Block Diagram	B-2
B-2	Interrupts 2 and 3 Block Diagram	B-3
B-3	Timer 1 System Clock Prescaler	B-4
B-4	Timer 1: Watchdog Timer	B-5
B-5	Timer 1: Dual Compare Mode	B-6
B-6	Timer 1: Capture/Compare Mode	B-8
B-7	Timer 2: Dual Compare Mode	B-10
B-8	Timer 2: Dual Capture Mode	B-12
B-9	SCI Block Diagram	B-14
B-10	Analog-to-Digital Converter Block Diagram	B-16
B-11	SPI Block Diagram	B-18
F-1	68-Pin PGA Pinout (Bottom View)	F-2
F-2	TMS370Cx5x Device PGA Pinout (Bottom View)	F-3
F-3	44-Pin PGA Pinout (Bottom View)	F-4
F-4	TMS370Cx3x Device PGA Pinout (Bottom View)	F-5
F-5	28-Pin PGA Pinout (Bottom View)	F-6
F-6	TMS370Cx1x Device PGA Pinout (Bottom View)	F-6
F-7	Pinouts for TMS370Cx1x (Top View)	F-7
F-8	Pinout for TMS370Cx3x (Top View)	F-8



---

F-9 Pinouts for TMS370Cx5x (Top View) ..... F-9

# Tables

---

---

1-1	TMS370 Family Features .....	1-3
2-1	TMS370 Family of 8-Bit Microcontrollers .....	2-3
2-2	TMS370 Family Feature Summary .....	2-5
2-3	TMS370Cx1x Pin Descriptions .....	2-10
2-4	TMS370Cx3x Pin Descriptions .....	2-12
2-5	TMS370Cx5x Pin Descriptions .....	2-15
3-1	Peripheral File Address Map .....	3-11
3-2	Vector Address Map .....	3-13
3-3	Memory Modes Available .....	3-15
3-4	Operating Mode Summary .....	3-24
4-1	Privilege-Mode Configuration Bits .....	4-3
4-2	Wait State Control Bits .....	4-5
4-3	Powerdown/Idle Control Bits .....	4-6
5-1	Module Interrupt Priority .....	5-3
5-2	Interrupt Vector Sources .....	5-4
5-3	Reset Sources .....	5-14
5-4	Control-Bit States Following Reset .....	5-15
7-1	Timer 1 I/O Pin Definitions .....	7-4
7-2	Timer 1 and Watchdog Counter Memory Map .....	7-5
7-3	Counter Overflow Rates .....	7-12
7-4	Timer 1 Compare Values: (CLKIN = 20 MHz) .....	7-17
8-1	Timer 2 Memory Map .....	8-4
8-2	Timer 2 Compare Values: (CLKIN = 20 MHz) .....	8-13
8-3	Timer 2 I/O Pin Definitions .....	8-13
8-4	Peripheral File Frame 6: Timer 2 Control Registers .....	8-17
9-1	SCI Memory Map .....	9-5
9-2	Asynchronous Baud Rate Register Values for Common SCI Baud Rates ..	9-8
9-3	SCI Control Registers .....	9-19

9-4	Transmitter Character Bit Length .....	9-20
9-5	Flags Affected by SCI SW RST .....	9-23
10-1	SPI Memory Map .....	10-4
10-2	Common SPI Bit Rates .....	10-7
10-3	SPI Character Bit Length .....	10-12
10-4	SPI Clock Frequency .....	10-13
11-1	A/D Memory Map .....	11-4
11-2	Peripheral File Frame 7: A-to-D Converter Control Registers .....	11-10
12-1	Number of Time Slots Available for Each Prescale Setting .....	12-17
12-2	Interrupt Vector Sources .....	12-30
13-1	Addressing Modes .....	13-3
13-2	TMS370 Symbol Definitions .....	13-18
13-3	TMS370 Family Instruction Overview .....	13-19
13-4	TMS370 Family Opcode/Instruction Map .....	13-28
13-5	Compare Instruction Examples – Status Bit Values .....	13-43
14-1	Wait State Control Bits .....	14-4
14-2	Memory Interface Timing .....	14-5
15-1	FFE Support of ROM Devices .....	15-27
16-1	Absolute Maximum Ratings over Operational Free-Air Temperature Range (unless otherwise noted) .....	16-2
16-2	Recommended Operating Conditions .....	16-3
16-3	Electrical Characteristics over Full Ranges of Recommended Operating Conditions .....	16-4
16-4	External Clocking Requirements .....	16-7
16-5	Switching Characteristics and Timing Requirements .....	16-7
16-6	General Purpose Output Signal Switching Time Requirements .....	16-8
16-7	Recommended EEPROM Timing Requirements for Programming .....	16-8
16-8	SPI Master External Timing Characteristics .....	16-9
16-9	SPI Master External Timing Requirements .....	16-9
16-10	SPI Slave External Timing Characteristics .....	16-10
16-11	SPI Slave External Timing Requirements .....	16-10
16-12	Absolute Maximum Ratings over Operating Free-air Temperature Range (unless otherwise noted) .....	16-11
16-13	Recommended Operating Conditions .....	16-12

16-14	Electrical Characteristics Over Full Ranges of Recommended Operating Conditions .....	16-13
16-15	External Clocking Requirements .....	16-16
16-16	Switching Characteristics and Timing Requirements .....	16-16
16-17	General Purpose Output Signal Switching Time Requirements .....	16-17
16-18	Recommended EPROM Operating Conditions for Programming .....	16-17
16-19	Recommended EPROM Timing Requirements for Programming .....	16-17
16-20	Recommended EEPROM Timing Requirements for Programming .....	16-17
16-21	Recommended Operating Conditions .....	16-18
16-22	Operating Characteristics Over Full Ranges of Recommended Operating Conditions .....	16-19
16-23	Analog Timing Requirements .....	16-20
16-24	Absolute Maximum Ratings over Operating Free-Air Temperature Range (unless otherwise noted) .....	16-21
16-25	Recommended Operating Conditions .....	16-22
16-26	Electrical Characteristics over Full Ranges of Recommended Operating Conditions .....	16-23
16-27	External Clocking Requirements .....	16-27
16-28	Peripheral Module and General Purpose Output Switching Time Requirements .....	16-27
16-29	Recommended EPROM Operating Conditions for Programming .....	16-28
16-30	Recommended EPROM Timing Requirements for Programming .....	16-28
16-31	Recommended EEPROM Timing Requirements for Programming .....	16-28
16-32	Switching Characteristics and Timing Requirements .....	16-29
16-33	SPI Master External Timing Characteristics .....	16-32
16-34	SPI Master External Timing Requirements .....	16-32
16-35	SPI Slave External Timing Characteristics .....	16-33
16-36	SPI Slave External Timing Requirements .....	16-33
16-37	SCI Isosynchronous Mode Timing Characteristics for Internal Clock ....	16-34
16-38	SCI Isosynchronous Mode Timing Requirements for Internal Clock ....	16-34
16-39	SCI Isosynchronous Mode Timing Characteristics for External Clock ...	16-35
16-40	SCI Isosynchronous Mode Timing Requirements for External Clock ....	16-35
16-41	Recommended Operating Conditions .....	16-36
16-42	A/D Converter Operating Characteristics over Full Range of Operating Conditions .....	16-37

---

16-43	Analog Timing Requirements .....	16-38
17-1	Package Types .....	17-6
C-1	ASCII Character Set .....	C-2
C-2	Control Characters .....	C-3
D-1	TMS370 Family Opcode/Instruction Map .....	D-2
E-1	TMS370 Family Instruction/Opcode Set .....	E-2
E-2	Bus Activity Tables .....	E-6



Introduction	1
Assembly Language Instruction Set	13
TMS370 Family Devices	2
Design Aids	14
CPU and Memory Organization	3
Development Support	15
System and Digital I/O Configuration	4
Electrical Specifications	16
Interrupts and System Reset	5
Customer Information	17
EEPROM Modules	6
Appendices	A-H
Timer 1 Module	7
Timer 2 Module	8
Serial Communications Interface (SCI) Port	9
Serial Peripheral Interface (SPI) Module	10
Analog-to-Digital Converter Module	11
TMS370 Programmable Acquisition and Control Timer	12





# Chapter 1

## Introduction

---

---

---

This manual describes the TMS370 family of microcontroller products. The objective of the manual is to provide the information needed to implement a microcontroller design using a TMS370 device.

This chapter gives a broad overview of the TMS370 family covering the following topics:

<b>Section</b>	<b>Page</b>
1.1 TMS370 Overview .....	1-2
1.2 TMS370 Architecture Overview .....	1-5
1.3 Manual Organization .....	1-11
1.4 Symbols and Conventions .....	1-12
1.5 Applicable Documents .....	1-13

## 1.1 TMS370 Overview

The TMS370 family consists of VLSI, 8-bit, CMOS microcontrollers with on-chip EEPROM storage and peripheral support functions. This family of microcontrollers provides superior performance in complex real-time control applications in demanding environments. With devices available in mask-programmable read-only memory (ROM), electrically-erasable programmable read-only memory (EEPROM), and electrically programmable read-only memory (EPROM), the designer has a significant range of options to choose from in deciding the most economical, efficient manner for getting a product to market.

The prototyping and production devices of the TMS370 family are totally interchangeable. This reduces development costs and cycle time, and facilitates rapid product modification and upgrade. The alterable non-volatile memory (EEPROM) allows a designer to customize his equipment for a specific application with quick turnaround.

The TMS370 family is fully supported by a host of TI development tools which provide simplified software development for quicker market introduction of new products. These development support tools include an Assembler, a Linker, a design kit, in-circuit emulators (XDS – eXtended Development Support), and an EEPROM/EPROM programmer. All of these tools work together using an MS™-DOS-based Personal Computer (PC) as the host and central control element. This allows selection of the host computer and the text management and editing tools based on user preference.

### TMS370 Features and Benefits

Features	Benefits
— Sub 2-Micron Technology	— Low power consumption over wide temperature range
— Series of compatible devices	— Supports software migration
— EPROM Technology	— Alterable, non-volatile memory on-chip to support form factor emulation and one-time programming (OTP*) option.
— EEPROM Technology	— Alterable, non-volatile memory on-chip to support in-socket programming and form factor emulation.
— A/D Technology	— Allows interface to analog signals.
— Versatile memory configurations	— Many memory options to meet applications requirements
— Programmable Interrupt Handling	— Provides design flexibility
— 14 Addressing Modes	— Increases programmer's flexibility during software development phase

\*For OTP (PLCC) availability information, contact local TI sales office or distributor.

**Table 1–1. TMS370 Family Features**

Feature	370Cx1x	370Cx3x	370Cx5x	Comments/Benefits
Program Memory	4 Kbytes ROM/EEPROM	8 Kbytes ROM/EPROM	4 – 16 Kbytes ROM/EPROM/EEPROM	Provides alternatives to meet the needs of the application.
Static RAM	128 bytes	256 bytes	256/512 bytes	Data retention in low-power modes.
Data EEPROM	0/256 bytes	0/256 bytes	0/256/512 bytes	Data retention in power-off mode. In-circuit programmability.
Watchdog Timer	Y	See Note	Y	Helps ensure system integrity, or can be used as general purpose Timer.
Timer 1	Y	–	Y	16-bit timer with 8-bit prescale. Up to 200 ns resolution at 20 MHz.
Timer 2	–	–	Y	16-bit timer with up to 200 ns resolution at 20 MHz.
PACT	–	Y	–	20-bit timer, with up to 6 input capture, 8 timer-driven outputs. 18 independent interrupt vectors. Watchdog with selectable time out period. Mini SCI.
A/D Converter	–	Y	Y	8 channel, 8-bit accuracy with selectable reference.
Serial Communications Interface	–	See Note	Y	Async. transmission up to 156 kbits/s; Sync transmission up to 2.5 Mbits/s; software selectable baud rate and data format.
Serial Peripheral Interface	Y	–	Y	Synchronous data transmission up to 2.5 Mbits/s.
External Interrupt	Y	Y	Y	Selectable edge detection
External Memory Bus Expansion	–	–	Y	Non-multiplexed address bus and data bus. Eliminates requirements for glue chips and saves board space.
Max. Digital I/O	22	36	55	Provides the designer with multi-purpose ports for increased flexibility.
Pin Count	28	44	68	Provides alternatives to meet the requirements of the application.
Packaging	DIP/PLCC	PLCC/CLCC	PLCC/CLCC	Supports high density surface mount.

**Note:** This function is included in the PACT module. See Chapter 12 for details.

## TMS370 Applications

### Industrial

- Motor control
- Temperature controllers
- Process control
- Meter control
- Medical instrumentation
- Security systems

### Automotive

- Climate control systems
- Cruise control
- Entertainment systems
- Instrumentation
- Navigational systems
- Engine control
- Anti-Lock Braking

### Telecommunications

- Modems
- Intelligent phones
- Intelligent line card control
- Telecopiers
- Debit cards

### Computer

- Keyboards
- Peripheral interface control
- Disk controllers
- Terminals

## 1.2 TMS370 Architecture Overview

The TMS370 family is based on a register-to-register architecture which allows access to a register file (up to 256 bytes) in a single bus cycle. On-chip memory includes Program Memory (mask ROM, EPROM, or EEPROM), Static RAM, and Data EEPROM.

The versatile on-chip peripheral functions include (depending on the specific member of the series) an Analog-to-Digital converter (A/D), a Serial Communications Interface (SCI), a Serial Peripheral Interface (SPI), 3 different Timer modules, and up to 55 digital Input/Output pins.

Figure 1-1 is a block diagram of the TMS370Cx1x devices, showing the major functional blocks.

**Figure 1-1. TMS370Cx1x Block Diagram**

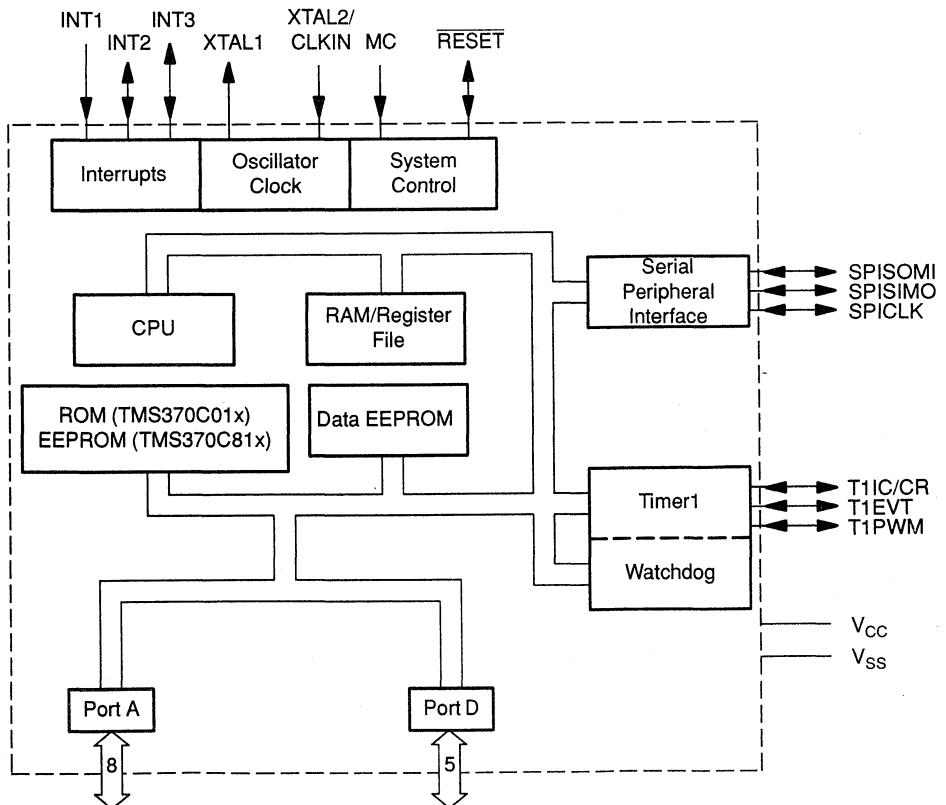
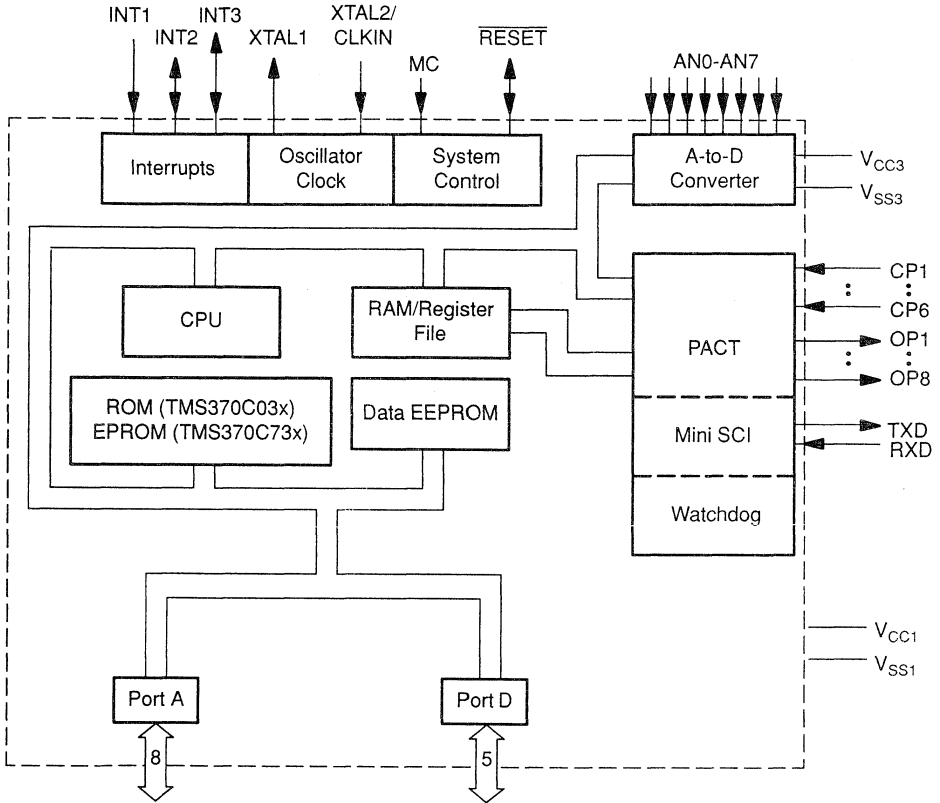


Figure 1–2 is a block diagram of the TMS370Cx3x devices, showing the major functional blocks.

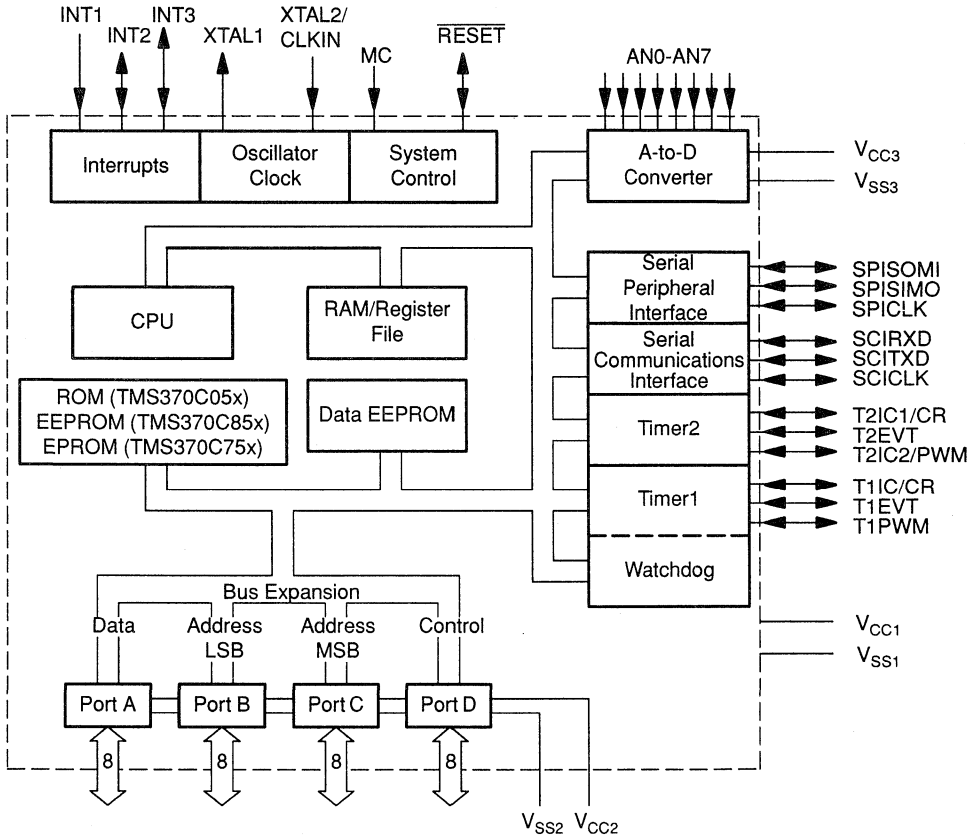
**Figure 1–2. TMS370Cx3x Block Diagram**



**Note:** Three of Port D's four I/O buffers (D4, D6, and D7) are internally connected to three of the PACT module's inputs (CP3, CP4, and CP5). This gives the actual pins D4/CP3, D6/CP4, and D7/CP5.

Figure 1–3 is a block diagram of the TMS370Cx5x devices, showing the major functional blocks.

**Figure 1–3. TMS370Cx5x Block Diagram**



## CPU

The TMS370 CPU is an 8-bit processor with status register, Program Counter register, and Stack Pointer internal to the CPU module. The CPU uses the register file as working registers, accessed on the internal bus in one bus cycle. The 8-bit internal bus also allows access to memory and the peripheral interfaces. TMS370Cx5x devices allow external bus expansion through Ports A, B, C, and D.

## Register File

The register file is located at the beginning of the TMS370 memory map. Register-access instructions in the TMS370 instruction set allow access to any of the first 256 registers (if available) in one bus cycle. This segment of the memory map is used as general purpose RAM and the stack.

## RAM

All other RAM modules are mapped after the register file. The TMS370 accesses this RAM in 2 cycles.

## Data EEPROM

The Data EEPROM modules contain 256 or 512 bytes of Electrically Erasable Programmable Read Only Memory. This memory is useful for constants and infrequently changed variables required by the application program. The EEPROM can be programmed and erased using available Programmers or by the TMS370 itself under program control.

## Program Memory

The Program Memory modules presently contain 4, 8, or 16 kilobytes of memory. The program memory in TMS370C8xx devices is EEPROM. EEPROM allows the devices to be programmed and reprogrammed in socket, for prototyping or small production runs. The program memory in TMS370C7xx devices is EPROM. EPROM can be programmed, erased, and reprogrammed for prototyping (in ceramic package). EPROM devices that do not have a window (in plastic package) are one time programmable (OTP) used for small production runs. In TMS370C0xx and TMS370C3xx devices, the program memory is mask ROM programmed at the factory.

## Input/Output Ports

**TMS370Cx1x** devices have two ports: Ports A and D. Port A is an 8-bit wide Port while Port D is a 5-bit wide Port. Both of these ports can be programmed, bit-by-bit, to function as either a digital input or a digital output.

**TMS370Cx3x** devices have two ports: Ports A and D. Port A is an 8-bit wide port while Port D is a 4-bit wide port. Both of these ports can be programmed, bit-by-bit, to function as either a digital input or a digital output.



**TMS370Cx5x** devices have four eight-bit ports: Ports A, B, C, and D. These ports can be configured by software as the data, control, and address lines for an external bus. Any bits not needed for an external bus can be programmed to be either a digital input or a digital output.

### **Watchdog Timer**

The Watchdog Timer can be programmed to generate a hardware reset when it times out. This function provides a hardware monitor over the software to prevent a "lost" program. If not needed as a watchdog, this timer can be used as a general purpose timer.

### **Timer 1 And Timer 2**

These timers can be programmed to one of many configurations to count events, compare the counter contents to a preset value, or time-out after a preset interval. The results of these operations can generate an interrupt to the CPU, set flag bits, reset the timer counter, toggle an I/O line, or generate pulse-width-modulated (PWM) outputs.

### **PACT, Programmable Acquisition and Control Timer**

The PACT module is a programmable timing module that uses some of the on-chip RAM to store its commands as well as the timer values. This module allows input capture on up to 6 pins, 4 of which have a programmable prescaler. One of the input capture pins can be used to drive an 8-bit event counter. Up to 8 outputs can be timer driven. The module has up to a 20-bit timer capability. There is also interaction between the event counter and the timer activity. This module has 18 independent interrupt vectors to allow better servicing of events. This module also contains a Watchdog timer with selectable time-out period, and a mini SCI which works as a full duplex UART. Once set up, the PACT requires no CPU overhead, except to service interrupts.

### **SCI, Serial Communications Interface**

The SCI module is a built-in serial interface which can be programmed to be asynchronous or isosynchronous. All timing, data format, and protocol factors are programmable and controlled by the SCI module in operation. The CPU takes no part in the serial communications except to write data to be transmitted to registers in the SCI and read received data from registers in the SCI when interrupted.

## **SPI, Serial Peripheral Interface**

The SPI module is a built-in serial interface which facilitates communication between network master, slave CPUs, and external peripheral devices. As in the SCI, the SPI is setup by software and from then on, the CPU takes no part in timing, data format, or protocol. Also, as in the SCI, the CPU reads and writes to memory mapped registers to receive and transmit data. An SPI interrupt alerts the CPU when received data is ready.

## **A-to-D Converter**

The A-to-D Converter module is an 8-channel, 8-bit, successive-approximation, analog-to-digital converter. The reference source and input channel are selectable. The conversion result can be programmed to be the ratio of the input voltage to the reference voltage or the ratio of one analog input to another. Input lines not required for A/D conversion can be programmed to be digital input lines.

## 1.3 Manual Organization

The following sections of this manual and their contents are summarized below.

### **Chapter 2: Family Devices**

Presents the features of TMS370 family members including pinouts.

### **Chapters 3 - 12**

Describes the operation and programming of each major function in the TMS370 architecture.

### **Chapter 13: Instruction Set**

Describes the TMS370 addressing modes and each of the 73 instructions including samples and examples.

### **Chapter 14: Design Aids**

Gives sample interface circuits and programming examples.

### **Chapter 15: Development Support**

Describes the hardware and software design-development tools available for the TMS370 series.

### **Chapter 16: Electrical Specifications**

Gives timing diagrams and electrical specifications.

### **Chapter 17: Customer Information**

Gives packaging, numbering, and ordering information.

### **Appendix A:**

Gives reference tables for TMS370 control bits.

### **Appendix B:**

Gives reference block diagrams with control bits.

### **Appendix C - E:**

Give reference tables for the TMS370 character set, instruction set, op-codes, and bus activity table.

### **Appendix F:**

Gives PLCC to PGA Pinout (bottom view) for the TMS370 devices.

### **Appendix G:**

Gives PACT.H macro used with PACT example programs.

### **Appendix H: Glossary**

### **Index**

## 1.4 Symbols and Conventions

The following symbols and conventions are used in this manual.

Symbol	Example	Description
(xxxxxx.n)	SPICTL.4	Bit location convention used in text, where 'xxxxxx' is the name of the register containing the bit and 'n' is the bit number (7 = msb, 0 = lsb).
(xx.n)	4A.0	Bit location convention used in figures, where 'xx' is the hexadecimal address of the peripheral register containing the bit and 'n' is the bit number (7 = msb, 0 = lsb).
h	1000h	Designates a number in the hexadecimal number system.
set		When used in reference to bits, means to write a logic 1 to the bit.
clear		When used in reference to bits, means to write a logic 0 to the bit.
P0n	P012	Hexadecimal Peripheral File (PF) address used in instructions accessing the PF. (i.e., P012 = P18)
Pn	P18	Decimal Peripheral File (PF) address used in instructions accessing the PF. (i.e., P18 = P012).
R0n	R010	Hexadecimal Register File (RF) address used in instructions accessing the RF. (i.e., R010 = R16)
Rn	R16	Decimal Register File (RF) address used in instructions accessing the RF. (i.e., R16 = R010)

## 1.5 Applicable Documents

- 1) *TMS370 Family Assembly Language Tools User's Guide*, SPNU010.
- 2) *TMS370 Family XDS/22 User's Guide*, SPNU008A.
- 3) *TMS370 Family XDS/11 User's Guide*, SPNU015.
- 4) *TMS370 Application Board User's Guide*, SPNU013.
- 5) *TMS370/EEPROM Programmer's User's Guide*, SPNU011.
- 6) *TMS370Cx5x 8-Bit Microcontrollers Data Sheet*, SPNS010A.
- 7) *TMS370Cx10 8-Bit Microcontrollers Data Sheet*, SPNS012A.
- 8) *TMS370Cx32 8-Bit Microcontrollers Data Sheet*, SPNS015.
- 9) *Using the TMS370 A/D Converter Module Application Report*, SPNA005.
- 10) *Using the TMS370 SPI and SCI Modules Application Report*, SPNA006.
- 11) *Using the TMS370 Timer Modules Application Report*, SPNA008.
- 12) *Using the TMS370 EEPROM Module Application Report* (planned).



Introduction	1
Assembly Language Instruction Set	13
TMS370 Family Devices	2
Design Aids	14
CPU and Memory Organization	3
Development Support	15
System and Digital I/O Configuration	4
Electrical Specifications	16
Interrupts and System Reset	5
Customer Information	17
EEPROM Modules	6
Appendices	A-H
Timer 1 Module	7
Timer 2 Module	8
Serial Communications Interface (SCI) Port	9
Serial Peripheral Interface (SPI) Module	10
Analog-to-Digital Converter Module	11
TMS370 Programmable Acquisition and Control Timer	12





# TMS370 Family Devices

This chapter discusses the features of the TMS370 family of microcomputers. All family members are software compatible, allowing easy migration within the TMS370 family by maintaining a software base, development tools, and design expertise.

The TMS370 family devices are divided into three categories:

- ❑ **TMS370Cx1x** devices which include the TMS370C010, TMS370C310, and TMS370C810
- ❑ **TMS370Cx3x** devices which include the TMS370C032, TMS370C332, and TMS370C732
- ❑ **TMS370Cx5x** devices which include the TMS370C050, TMS370C150, TMS370C250, TMS370C350, TMS370C850, TMS370C052, TMS370C352, TMS370C056, TMS370C156, TMS370C256, TMS370C356, and TMS370C756.

All categories are supported by development tools that include the in-circuit emulators, Assembler, and Linker.

This chapter begins with a summary and comparison of the TMS370 family devices, and then provides key features, pinouts, and pin descriptions for the individual categories.

<b>Section</b>	<b>Page</b>
2.1 Summary and Device Comparison .....	2-4
2.2 TMS370 Features .....	2-6
2.3 TMS370 Family Pinouts/Pin Descriptions .....	2-9

Table 2-1 shows all of the standard devices available at time of printing. For current list of available family members check with the local Texas Instruments Field Sales Office or the 8-bit Microcontroller Technical Hotline.

Table 2-1. TMS370 Family of 8-Bit Microcontrollers

Device	Program Memory (Bytes)		Data Memory (Bytes)		Off-Chip Memory Expansion (Bytes)	Serial Interface Modules	Timer Modules	A/D Channels	I/O Pins	No. of Pins /Package
	ROM	EEPROM	EEPROM	RAM						
ROM	370C010	4K	—	256	None	SPI	T1	—	22	28 DIP/PLCC
	370C050	4K	—	256	112K	SPI/SCI	T1/T2	8	55	68 PLCC
	370C032	8K	—	256	None	PACT-SCI	PACT	8	36	44 PLCC
	370C052	8K	—	256	112K	SPI/SCI	T1/T2	8	55	68 PLCC
370C056	16K	—	512	112K	SPI/SCI	T1/T2	8	55	68 PLCC	
ROM-less§	370C310	4K	—	128	None	SPI	T1	—	22	28 DIP/PLCC
	370C350	4K	—	256	112K	SPI/SCI	T1/T2	8	55	68 PLCC
	370C332	8K	—	256	None	PACT-SCI	PACT	8	36	44 PLCC
	370C352	8K	—	256	112K	SPI/SCI	T1/T2	8	55	68 PLCC
370C356	16K	—	512	112K	SPI/SCI	T1/T2	8	55	68 PLCC	
ROM-less§	370C150	—	—	256	112K	SPI/SCI	T1/T2	8	55	68 PLCC
	370C250	—	—	256	112K	SPI/SCI	T1/T2	8	55	68 PLCC
	370C156	—	—	512	112K	SPI/SCI	T1/T2	8	55	68 PLCC
	370C256	—	—	512	112K	SPI/SCI	T1/T2	8	55	68 PLCC
FFE	370C810	—	4K	256	None	SPI	T1	—	22	28 DIP/PLCC
	370C850	—	4K	256	112K	SPI/SCI	T1/T2	8	55	68 PLCC
	370C732	—	8K	256	None	PACT-SCI	PACT	8	36	44 CLCC¶
	370C756	—	16K	512	112K	SPI/SCI	T1/T2	8	55	68 CLCC¶

◇ Timer 1 module has a Watchdog timer included which can be programmed to a general purpose 16 bit timer.

PACT module has a Watchdog timer included.

♣ PACT module has a mini SCI port.

§ In ROM-less (microprocessor) mode all Address, Data, and Control lines are fixed as their function.

¶ For OTP (PLCC) availability information, contact local TI sales office or distributor.

2

## 2.1 Summary and Device Comparison

The TMS370 family **CMOS** devices contain multiple modules as illustrated in Table 2–2 and can be summarized as follows:

- ❑ The **TMS370Cx1x** are 8-bit, single-chip microcomputers, containing a CPU, a 16-bit timer (with Watchdog timer), flexible I/O, a Serial Peripheral Interface, static RAM, and an optional Data EEPROM. The Form Factor Emulator (FFE) has user programmable program memory (EEPROM) in place of ROM.
- ❑ The **TMS370Cx3x** devices are 8-bit, single chip microcomputers, containing a CPU, a programmable timing module (PACT) with built-in Watchdog timer and a mini serial communications interface, an eight channel 8-bit A/D converter, flexible I/O, static RAM, and optional Data EEPROM. The Form Factor Emulator (FFE) has user programmable program memory (EPROM) in place of ROM.
- ❑ The **TMS370Cx5x** devices have the same basic features as the TMS370Cx1x with the addition of another 16-bit timer (Timer 2), a Serial Communications Interface, memory expansion ports, and an eight channel 8-bit A/D converter. The Form Factor Emulators (FFE) have user programmable program memory (EEPROM or EPROM) in place of ROM.
- ❑ Development tools include a design kit (for evaluation), in-circuit emulators, device programmers, assembler, and linker.

Table 2–2. TMS370 Family Feature Summary

Feature	TMS370Cx1x	TMS370Cx3x	TMS370Cx5x
Oscillator Frequency Range	2 - 20 MHz	2 - 20 MHz	2 - 20 MHz
Voltage	5 V $\pm$ 10%	5 V $\pm$ 10%	5 V $\pm$ 10%
Operating temperature	-40°C to 85°C	-40°C to 85°C	-40°C to 85°C
Program Memory	4 Kbyte ROM / EEPROM	8 Kbyte ROM / EPROM	0–16 Kbyte ROM / EPROM / EEPROM
Static RAM	128 bytes	256 bytes	256 / 512 bytes
Data EEPROM	0 / 256 bytes	0 / 256 bytes	0 / 256 / 512 bytes
<b>Modules</b>			
SPI	Yes	–	Yes
Timer 1	Yes	–	Yes
Watchdog Timer	Yes	See Note.	Yes
Timer 2	–	–	Yes
PACT	–	Yes	–
SCI	–	See Note.	Yes
A/D Converter	–	Yes	Yes
<b>Maximum Digital I/O</b>			
Bidirectional	21	14	46
Input Only	1	13	9
Output Only	0	9	0
External Memory Bus Expansion	No	No	Yes
<b>Interrupts/Reset</b>			
External	4	4	4
Vectors total	6	23	10
Sources total	13	25	23
Pin Count	28	44	68
Packaging	DIP / PLCC	PLCC / CLCC	PLCC / CLCC

**Note:** This function is included in the PACT module.

## 2.2 TMS370 Family Features

2

The following are key features of all TMS370 family members.

- ❑ CMOS EEPROM Technology
  - EEPROM programming with single 5-volt supply.
  - EEPROM for reprogrammable program memory (FFE), used for prototypes and can be reprogrammed in socket.
- ❑ CMOS EPROM Technology
  - EPROM for reprogrammable program memory (FFE), used for prototypes and small volume production.
- ❑ CMOS A/D Technology
  - Conversion of analog signals to digital values.
- ❑ Static RAM/Registers
- ❑ Flexible operating features
  - Power reduction STANDBY and HALT modes
  - -40°C to 85°C operating temperature
  - 2 MHz to 20 MHz input clock frequency
- ❑ Flexible interrupt handling
  - Two software programmable interrupt levels
  - Programmable rising or falling edge detect
- ❑ System integrity features
  - Oscillator fault detection
  - Privileged mode lockout
  - Watchdog timer
- ❑ Memory-mapped ports for easy addressing
- ❑ 14 addressing modes using eight formats, including:
  - Register-to-register arithmetic
  - Indirect addressing
  - Indexed and indirect branches and calls
- ❑ 250 mA typical latch-up immunity at 25°C
- ❑ ESD protection exceeds 2,000 V per MIL-STD -883C Method 3015

## 2.2.1 TMS370Cx1x Features

The TMS370Cx1x devices contain the features of the TMS370 family shown in Section 2.2 plus these additional capabilities.

- 16-bit general-purpose timer (Timer 1), software configurable as:
  - Programmable 8-bit prescaler for effective 24-bit timer
  - 16-bit event timer
  - 16-bit pulse accumulator
  - 16-bit input-capture function
  - Two 16-bit compare registers
  - Self contained PWM output function
- On-chip 24-bit watchdog timer (Timer 1)
- Serial peripheral interface (SPI)
  - Variable-length high-speed shift register
  - Synchronous master/slave operation
  - Error detection flags

## 2.2.2 TMS370Cx3x Features

The TMS370Cx3x devices contain the features of the TMS370 family shown in Section 2.2 plus these additional capabilities:

- Eight channel 8-bit A/D converter
- Programmable Acquisition and Control Timer (PACT) module
  - Input capture on up to 6 pins, 4 of which may have a programmable prescaler
  - One input capture pin can drive an 8-bit event counter
  - Up to 8 timer driven outputs
  - Up to 20-bit timer capability
  - Interaction between event counter and timer activity
  - 18 independent interrupt vectors
  - Watchdog with selectable time-out period
  - Mini SCI

### 2.2.3 TMS370Cx5x Features

The TMS370Cx5x devices contain the features of the TMS370 family shown in Section 2.2 plus these additional capabilities:

- ❑ 16-bit general purpose timer (Timer 1), software configurable as:
  - Programmable 8-bit prescaler for effective 24-bit timer
  - 16-bit event timer
  - 16-bit pulse accumulator
  - 16-bit input-capture function
  - Two 16-bit compare registers
  - Self contained PWM output function
- ❑ On-chip 24-bit watchdog timer (Timer 1)
- ❑ Serial peripheral interface (SPI)
  - Variable-length high-speed shift register
  - Synchronous master/slave operation
  - Error detection flags
- ❑ Second 16-bit (Timer 2) timer
- ❑ Eight channel 8-bit A/D converter
- ❑ Serial communications interface (SCI)
  - Asynchronous and Isosynchronous modes
  - Full duplex, double buffered Rx and Tx
  - Programmable format with error checking capabilities
- ❑ Flexible system memory configurations
  - Precoded external chip select outputs
  - Programmable external memory/peripheral WAIT states
  - Addressable memory expansion to over 112 Kbytes
  - No logic needed for external memory addressing
  - WAIT line to extend bus cycles



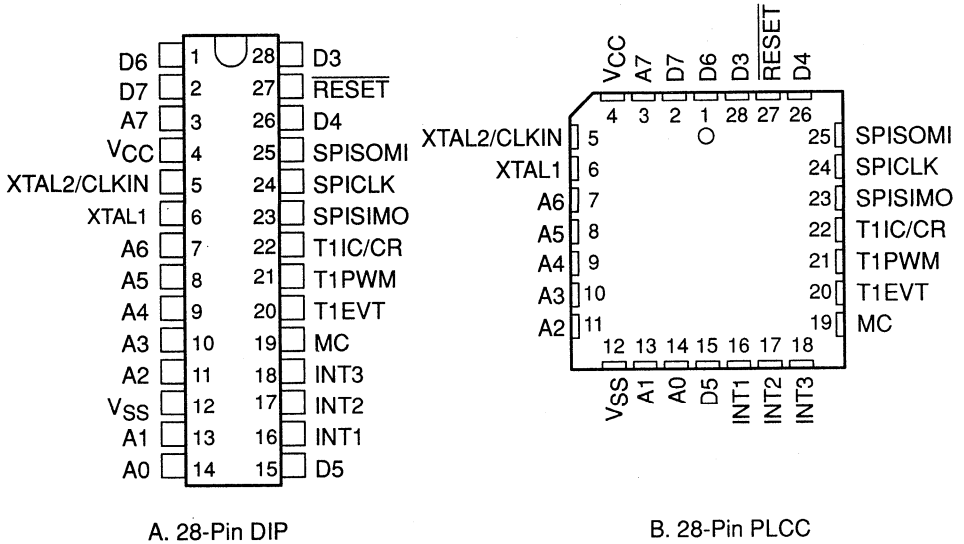
## 2.3 TMS370 Family Pinouts/Pin Descriptions

### 2.3.1 TMS370Cx1x Pinouts

2

The pinouts for the TMS370Cx1x devices are shown below.

Figure 2–1. Pinouts for TMS370Cx1x



## 2.3.2 TMS370Cx1x Pin Descriptions

2 Table 2–3. TMS370Cx1x Pin Descriptions

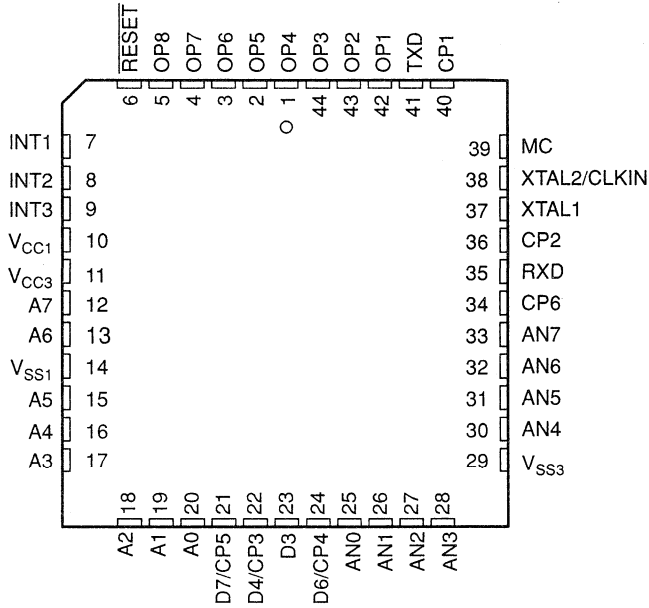
Pin		I/O	Description (see Note)
Name	No.		
A0	14	I/O	Port A is a general purpose bidirectional I/O port.
A1	13	I/O	
A2	11	I/O	
A3	10	I/O	
A4	9	I/O	
A5	8	I/O	
A6	7	I/O	
A7	3	I/O	
D3	28	I/O	Port D is a general purpose bidirectional I/O port. I/O pin: also configurable as CLKOUT.
D4	26	I/O	
D5	15	I/O	
D6	1	I/O	
D7	2	I/O	
INT1	16	I	External non-maskable or maskable interrupt/general purpose input pin
INT2	17	I/O	
INT3	18	I/O	
T1IC/CR	22	I/O	Timer 1 Input Capture/Counter Reset input pin/general purpose bidirectional pin.
T1PWM	21	I/O	
T1EVT	20	I/O	
SPI SOMI	25	I/O	SPI Slave Output pin. Master Input pin/general purpose bidirectional pin.
SPI SIMO	23	I/O	
SPI CLK	24	I/O	
RESET	27	I/O	System reset bidirectional pin. As an input it initializes microcontroller, as an open-drain output it indicates an internal failure was detected by the Watchdog or Oscillator Fault circuit.
MC	19	I	Mode control input pin; enables EEPROM Write Protection Override (WPO) mode.
XTAL2/ CLKIN	5	I	Internal oscillator crystal input/External clock source input.
XTAL1	6	O	
Vcc	4		Positive supply voltage
Vss	12		Ground reference

**Note:** Each pin associated with Interrupt 2, Interrupt 3, Timer 1, and SPI functional blocks may be individually programmed as a general purpose bidirectional pin if it is not used for its primary block function. D3 may be configured as CLKOUT by appropriately programming the DPORT1 and DPORT2 registers.

### 2.3.3 TMS370Cx3x Pinouts

The pinouts for the TMS370Cx3x devices are shown below.

Figure 2–2. Pinout for TMS370Cx3x



## 2.3.4 TMS370Cx3x Pin Descriptions

**2** Table 2–4. TMS370Cx3x Pin Descriptions

Pin		I/O	Description
Name	No.		
A0 A1 A2 A3 A4 A5 A6 A7	20 19 18 17 16 15 13 12	I/O I/O I/O I/O I/O I/O I/O I/O	Port A is a general purpose bidirectional port.
D3 D4/CP3 D6/CP4 D7/CP5	23 22 24 21	I/O I/O I/O I/O	Port D is a general purpose bidirectional port. I/O pin: Also configurable as CLKOUT. (See Note 1.) I/O pin: PACT input capture 3. (See Note 2.) I/O pin: PACT input capture 4. (See Note 2.) I/O pin: PACT input capture 5. (See Note 2.)
INT1  INT2  INT3	7  8  9	I  I/O  I/O	External interrupt (non-maskable or maskable)/general purpose input pin. Externable maskable interrupt input/general purpose bidirectional pin. Externable maskable interrupt input/general purpose bidirectional pin.
CP1 CP2 CP6	40 36 34	I I I	PACT input capture pin 1. PACT input capture pin 2. PACT input capture pin 6. External Event input pin (for event counter).
TXD RXD	41 35	O I	PACT SCI transmit output pin. PACT SCI receive input pin.
OP1 OP2 OP3 OP4 OP5 OP6 OP7 OP8	42 43 44 1 2 3 4 5	O O O O O O O O	PACT output pin 1. PACT output pin 2. PACT output pin 3. PACT output pin 4. PACT output pin 5. PACT output pin 6. PACT output pin 7. PACT output pin 8.

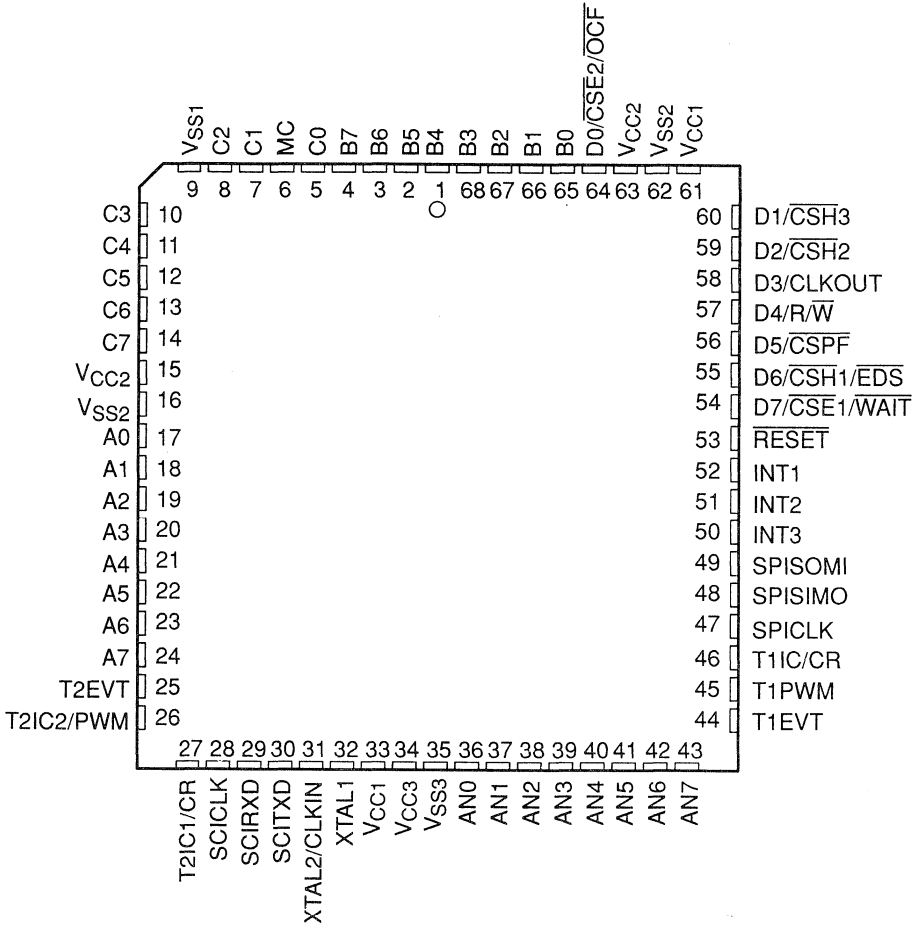
- Notes:**
- 1) D3 may be configured as CLKOUT by appropriately programming the DPORT1 and DPORT2 registers.
  - 2) Some of Port D's digital I/O buffers are internally connected to some of the PACT module's input capture pins. This allows the microcontroller to read the level on the input capture pin, or if the Port D pin is configured as an output, to generate a capture. Be careful to leave the Port D pin configured as an input if the corresponding input capture pin is being driven by external circuitry.

Table 2-4. TMS370Cx3x Pin Descriptions (Concluded)

Pin		I/O	Description
Name	No.		
AN0	25	I	A/D analog input (AN0—AN7) or positive reference pins (AN1—AN7).  The analog port may be individually programmed as general purpose input pins if not used as A/D converter analog input or positive reference input.
AN1	26	I	
AN2	27	I	
AN3	28	I	
AN4	30	I	
AN5	31	I	
AN6	32	I	
AN7	33	I	
$\overline{\text{RESET}}$	6	I/O	System reset bidirectional pin. As input it initializes microcontroller, as open-drain output it indicates an internal failure was detected by the watchdog or oscillator fault circuit.
MC	39	I	Microcomputer mode control input pin, also enables EEPROM write protection override (WPO) mode.
XTAL2/ CLKIN	38	I	Internal oscillator crystal input./External clock source input.
XTAL1	37	O	Internal oscillator output for crystal.
$V_{CC1}$	10		Positive supply voltage for digital logic and digital I/O pins. Ground reference for digital logic and digital I/O pins.  A/D converter positive supply voltage and optional positive reference input. A/D converter ground supply and low reference input pin.
$V_{SS1}$	14		
$V_{CC3}$	11		
$V_{SS3}$	29		

### 2.3.5 TMS370Cx5x Pinouts

**2** Figure 2–3. Pinouts for TMS370Cx5x



## 2.3.6 TMS370Cx5x Pin Descriptions

**Table 2–5. TMS370Cx5x Pin Descriptions**

Pin			I/O	Description
Name	Alternate Function	No.		
A0	DATA0 (LSB)	17	I/O	Single-chip mode: Port A is a general purpose bidirectional port.  Expansion mode: Port A may be individually programmed as the external bidirectional data bus (DATA0–DATA7).
A1	DATA1	18	I/O	
A2	DATA2	19	I/O	
A3	DATA3	20	I/O	
A4	DATA4	21	I/O	
A5	DATA5	22	I/O	
A6	DATA6	23	I/O	
A7	DATA7 (MSB)	24	I/O	
B0	ADD0	65	I/O	Single chip mode: Port B is a general purpose bidirectional I/O port.  Expansion modes: Port B may be individually programmed as the low order address output bus (ADD0–ADD7)
B1	ADD1	66	I/O	
B2	ADD2	67	I/O	
B3	ADD3	68	I/O	
B4	ADD4	1	I/O	
B5	ADD5	2	I/O	
B6	ADD6	3	I/O	
B7	ADD7	4	I/O	
C0	ADD8	5	I/O	Single chip mode: Port C is a general purpose bidirectional I/O port.  Expansion mode: Port C may be individually programmed as the high order address output bus (ADD8–ADD15).
C1	ADD9	7	I/O	
C2	ADD10	8	I/O	
C3	ADD11	10	I/O	
C4	ADD12	11	I/O	
C5	ADD13	12	I/O	
C6	ADD14	13	I/O	
C7	ADD15	14	I/O	
INT1	INTIN	52	I	External interrupt (non-maskable or maskable)/ General purpose input pin. External maskable interrupt input/General purpose bidirectional pin. External maskable interrupt input/General purpose bidirectional pin.
INT2	INTI01	51	I/O	
INT3	INTI02	50	I/O	

Table 2–5. TMS370Cx5x Pin Descriptions (Continued)

2	Name	Alternate Function		No.	I/O	Description
		Function A                      B				
						Single chip mode: Port D is a general purpose bidirectional I/O port. Each of the Port D pins can be individually configured as either a general purpose I/O pin, primary memory control signal (Function A), or secondary memory control signal (Function B). All chip selects are independent and can be used for memory bank switching.
	D0	$\overline{\text{CSE2}}$	$\overline{\text{OCF}}$	64	I/O	I/O pin/A: Chip Select Eighth output 2 goes low during memory accesses to 2000h–3FFFh /B: Opcode fetch goes low during the opcode fetch memory cycle.
	D1	$\overline{\text{CSH3}}$		60	I/O	I/O pin/A: Chip Select Half output 3 goes low during memory accesses to 8000h–FFFFh.
	D2	$\overline{\text{CSH2}}$		59	I/O	I/O pin/A: Chip Select Half output 2 goes low during memory accesses to 8000h–FFFFh.
	D3	CLKOUT	CLK-OUT	58	I/O	I/O pin/A, B: Internal clock signal is 1/4 XTAL2/CLKIN frequency.
	D4	R/W	R/W	57	I/O	I/O pin/A, B: Read/Write output pin.
	D5	$\overline{\text{CSPF}}$		56	I/O	I/O pin/A: Chip Select Peripheral output for peripheral file goes low during memory accesses to 10C0h–10FFh.
	D6	$\overline{\text{CSH1}}$	$\overline{\text{EDS}}$	55	I/O	I/O pin/A: Chip Select Half output 1 goes low during memory accesses to 8000h–FFFFh/B: External Data Strobe output goes low during memory accesses from external memory and has the same timings as the five chip selects.
	D7	$\overline{\text{CSE1}}$	$\overline{\text{WAIT}}$	54	I/O	I/O pin/A: Chip Select Eighth output goes low during memory accesses to 2000h–3FFFh /B: Wait input pin extends bus signals.
	T1IC/CR	T1I01		46	I/O	Timer 1 Input Capture/Counter Reset input pin/General purpose bidirectional pin.
	T1PWM	T1I02		45	I/O	Timer 1 PWM output pin/General purpose bidirectional pin.
	T1EVT	T2I03		44	I/O	Timer 1 External Event input pin/General purpose bidirectional pin.
	T2IC1/CR	T2I01		27	I/O	Timer 2 Input Capture 1/Counter Reset input pin/General purpose bidirectional pin.
	T2IC2/ PWM	T2I02		26	I/O	Timer 2 Input Capture 2/PWM output pin/general purpose bidirectional pin.
	T2EVT	T2I03		25	I/O	Timer 2 External Event input pin/general purpose bidirectional pin.



Table 2-5. TMS370Cx5x Pin Descriptions (Continued)

Pin			I/O	Description
Name	Alternate Function	No.		
SPISOMI	SPIIO1	49	I/O	SPI Slave Output pin, Master Input pin/general purpose bidirectional pin.
SPISIMO	SPIIO2	48	I/O	SPI Slave Input pin, Master Output pin/general purpose bidirectional pin.
SPICLK	SPIIO3	47	I/O	SPI bidirectional Serial Clock pin/general purpose bidirectional pin.
SCITXD	SCIIO1	30	I/O	SCI Transmit Data output pin/general purpose bidirectional pin.
SCIRXD	SCIIO2	29	I/O	SCI Receive Data Input pin/general purpose bidirectional pin.
SCICLK	SCIIO3	28	I/O	SCI bidirectional Serial Clock pin/general purpose bidirectional pin.
AN0	E0	36	I	A/D analog input (AN0-AN7) or positive reference pins (AN1-AN7).  Port E may be individually programmed as general purpose input pins if not used as A/D converter analog input or positive reference input.
AN1	E1	37	I	
AN2	E2	38	I	
AN3	E3	39	I	
AN4	E4	40	I	
AN5	E5	41	I	
AN6	E6	42	I	
AN7	E7	43	I	
V <sub>CC3</sub>		34		A/D converter positive supply voltage and optional positive reference input pin.
V <sub>SS3</sub>		35		A/D converter ground supply and low reference input pin.
RESET		53	I/O	System reset bidirectional pin. As an input it initializes microcontroller, as open-drain output it indicates an internal failure was detected by the Watchdog or Oscillator Fault circuit.
MC		6	I	Microprocessor/microcomputer mode control pin, also enables EEPROM Write Protection Override (WPO) mode.
XTAL2/ CLKIN		31	I	Internal oscillator crystal input/External clock source input.
XTAL1		32	O	Internal oscillator output for crystal.
V <sub>CC1</sub>		33, 61		Positive supply voltage for digital logic.
V <sub>CC2</sub>		15, 63		Positive supply voltage for digital I/O pins.
V <sub>SS1</sub>		9		Ground reference for digital logic.
V <sub>SS2</sub>		16, 62		Ground reference for digital I/O pins.

**Note:** Each pin associated with the Interrupt, Timer 1, Timer 2, SPI, and SCI functional blocks may be individually programmed as a general purpose bidirectional pin if it is not used for its primary block function.



Introduction	1
Assembly Language Instruction Set	13
TMS370 Family Devices	2
Design Aids	14
CPU and Memory Organization	3
Development Support	15
System and Digital I/O Configuration	4
Electrical Specifications	16
Interrupts and System Reset	5
Customer Information	17
EEPROM Modules	6
Appendices	A-H
Timer 1 Module	7
Timer 2 Module	8
Serial Communications Interface (SCI) Port	9
Serial Peripheral Interface (SPI) Module	10
Analog-to-Digital Converter Module	11
TMS370 Programmable Acquisition and Control Timer	12



# CPU and Memory Organization

This chapter describes the CPU registers and memory organization. In the TMS370 register-to-register architecture, the CPU and up to the first 256 bytes of RAM act as a single unit along with the program counter, stack pointer, and status register.

This chapter covers the following topics:

<b>Section</b>	<b>Page</b>
3.1 CPU/Register File Interaction .....	3-2
3.2 CPU Registers .....	3-3
3.3 Memory Map .....	3-8
3.4 Memory Operating Modes .....	3-15

### 3.1 CPU/Register File Interaction

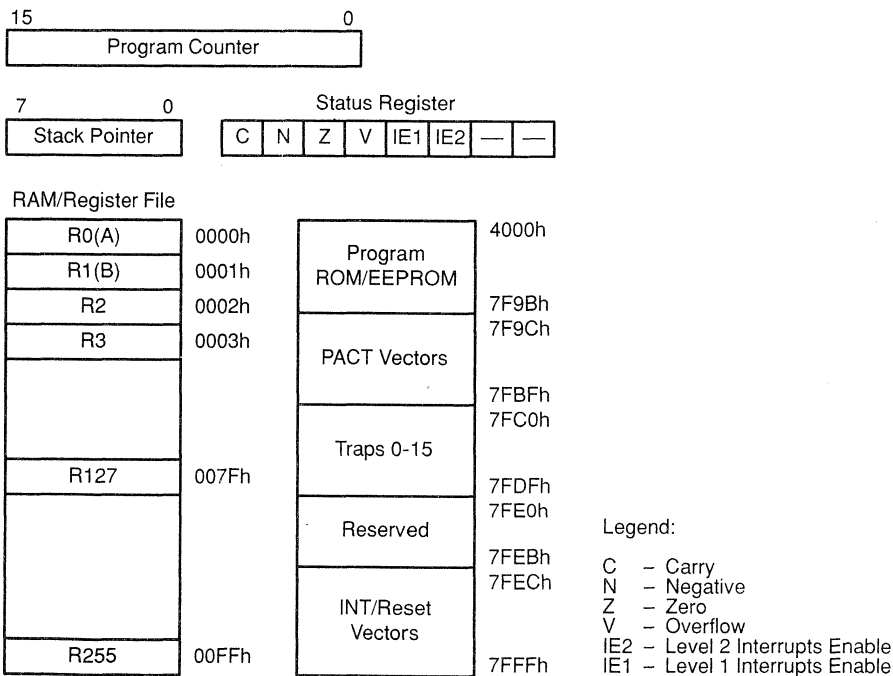
The first 256 address locations in the memory space, 0000h through 00FFh (0000h–007Fh for devices with only 128 bytes of RAM), are called the *register file*. Any location in this block can be accessed as: a general purpose register, data memory storage, program instructions, or part of the stack.

3

Registers R0 and R1 are also called A and B respectively. Some instructions imply Registers A or B. For example, the instruction `LDSP` assumes that the value to be loaded into the stack pointer is contained in Register B.

This multiple use of the register file gives designers the flexibility to use the register file however they wish. The partitioning of the register file is determined by the value loaded into the stack pointer and the use of the register file by the program.

Figure 3–1. Programmer’s Model



## 3.2 CPU Registers

The CPU contains three registers to control the status and direction of the program. These are the: stack pointer, status register, and program counter. These registers and their use are described in the following paragraphs.

### 3.2.1 Stack Pointer (SP)

The stack operates as a last-in, first-out, read/write memory. The stack is typically used to store the return address on subroutine calls and the status register contents during interrupts.

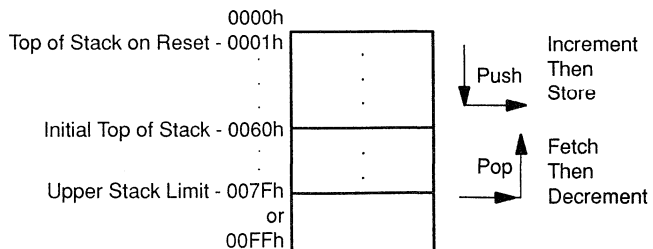
The stack pointer (SP) is an 8-bit CPU register that points to the last entry or top of the stack. The SP is automatically incremented *before* data is pushed onto the stack and decremented *after* data is popped from the stack.

The stack can be placed anywhere in the register file. During reset, the SP is loaded with 01h. To control the area occupied by the stack, the application program must set the stack pointer and include code to monitor the stack size.

The SP is loaded from Register B (R1) using the assembly language instruction `LDSP`. The `LDSP` instruction allows the stack to be located anywhere in the register file space. The SP may be read into Register B using the `STSP` command. Figure 3–2 illustrates an example SP initialization and stack operation.

```
INIT   MOV   #60h,B           ;Load Register B with the value
                                ;60h.
                                LDSP          ;Load the stack pointer with the
                                ;contents of Register B.
```

**Figure 3–2. Stack Example**



For devices with 256 (or more) bytes of RAM, if the stack is pushed beyond its limit of 00FFh, the SP register wraps around from 00FFh to 0000h without an error indication. The stack for devices with only 128 bytes of RAM is not implemented beyond 007Fh; data pushed beyond this limit is lost. The application program must guard against stack overflow.

**3**



### 3.2.2 Status Register (ST)

The ST register includes four status bits and two interrupt enable bits. The four status bits indicate the outcome of the previous instruction. Conditional instructions (for example, the conditional jump instructions) use these status bits to determine program flow. The two interrupt bits control the two interrupt levels. The ST register, status bit notation, and status bit definitions are as follows:

Bit #—	7	6	5	4	3	2	1	0
	C	N	Z	V	IE2	IE1	—	—
	RW–0	RW–0	RW–0	RW–0	RW–0	RW–0		

R=Read, W=Write, –n = Value after reset

- Bits 0–1 - Reserved. Read data is indeterminate.
- Bit 2 - **IE1**. Level 1 Interrupt Enable.  
This bit controls interrupt level 1 (highest priority).  
0 = disable interrupt requests from priority level 1.  
1 = enable interrupt requests from priority level 1.
- Bit 3 - **IE2**. Interrupt Enable, Chain 2.  
This bit controls interrupt level 2 (lowest priority).  
0 = disable interrupt requests from priority level 2.  
1 = enable interrupt requests from priority level 2.
- Bit 4 - **V**. Overflow.  
Set by the CPU if a signed arithmetic overflow condition was detected during the previous instruction. The value of this flag is significant at the completion of the following instructions: ADC, ADD, SUB, SBB, CMP, DIV.

Instruction	V = 1 if,
ADC, ADD, INC, INCW	(C XOR N) AND (Bit 7{s} XNOR Bit 7{d})
CMP, DEC, SUB, SBB	(C XOR N) AND (Bit 7{s} XOR Bit 7{d})
DIV (Rs, A)	1 if $R_s \leq A$ , which means quotient > 255

- Bit 5 - **Z**. Zero.  
Set by the CPU if the result of the previous operation was 0; cleared otherwise.
- Bit 6 - **N**. Negative.  
CPU sets this bit to the value of the most significant bit (sign bit) of the result of the previous operation.
- Bit 7 - **C**. Carry.  
This status bit is set by arithmetic instructions as a carry bit or as a no-borrow bit. It is also effected by the rotate instructions. See each instruction in Section 13 for a detailed description of how the Carry bit is used.

When the CPU acknowledges an interrupt, the contents of the status register are automatically pushed onto the stack, then the status register is cleared (for more information on interrupt effects on the status register, see Section 5.1.1). The normal exit from an interrupt service routine is made with the RTI instruction. When the CPU executes the RTI instruction, it automatically restores the content of the status register with a stack-pop operation.

The four condition flags (C, N, Z, and V) are updated every time an instruction is executed which manipulates or moves data. Thus, conditional branches should be performed immediately after a data manipulation operation. The instructions that *do not* affect the contents of these flags are:

- |                                 |           |
|---------------------------------|-----------|
| – TRAP 0 through TRAP 15        | – IDLE    |
| – CALL                          | – NOP     |
| –CALLR                          | – PUSH ST |
| – BR                            | – RTS     |
| – DJNZ                          | – STSP    |
| – JMP                           | – JMPL    |
| – Conditional Jump instructions | – LDSP    |

The LDST instruction allows a program to change all bits in the status register. The byte following this instruction is loaded directly into the status register. The assembly language instructions DINT, EINT, EINTH, and EINTL enable specific interrupts. These instructions are converted to a "LDST #iop8" opcode by the assembler so that "#iop8" is the appropriate value to set or clear the specific interrupt (see Section 13 for more information on the LDST instruction).

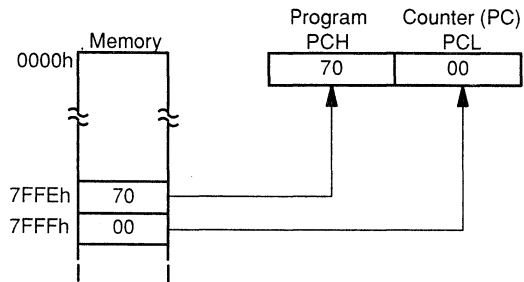
The carry (C) bit can be set with the SETC opcode and cleared with the CLRC opcode.

### 3.2.3 Program Counter

The contents of the program counter (PC) point to the memory location of the next instruction to be executed. The PC consists of two 8-bit registers in the CPU: the Program Counter High (PCH) and Program Counter Low (PCL). These registers contain the MSB and LSB of a 16-bit address.

During reset, the PCH (MSB of the PC) is loaded with the contents of memory location 7FFEh and the PCL (LSB of the PC) is loaded with the contents of memory location 7FFFh. Figure 3–3 illustrates this operation using an example value of 7000h as the contents of memory locations 7FFEh and 7FFFh (Reset vector).

**Figure 3–3. Program Counter After Reset**



### 3.3 Memory Map

Figure 3–4 shows the memory map of the present TMS370 family members. The partitioning of memory and physical location of memory (that is, on or off-chip) depends on the device used and the memory mode of operation. The memory modes of operation are discussed in Section 3.4.

Each device that has bus expansion can be programmed to use up to 16 address bits. This allows access of up to 64 kilobytes of memory. In addition, memory expansion features allow up to 112 kilobytes of external memory. (The expansion features are described further in Section 3.4.2.)

Figure 3–4. TMS370 Memory Map

0000h	256 Byte RAM (Register File/Stack)
00FFh	
0100h	RAM Expansion (On-Chip) <sup>†</sup>
1000h	Peripheral File
10BFh	
10C0h	Peripheral File Expansion
10FFh	Data EEPROM Expansion (On-Chip)
1100h	
1EFFh	256-Byte Data EEPROM
1F00h	
1FFFh	Memory Expansion/External Memory
2000h	
3FFFh	16-Kbyte Program Memory Start or Microprocessor Mode Memory Expansion
4000h	
5FFFh	8-Kbyte Program Memory Start or Microprocessor Mode Memory Expansion
6000h	
6FFFh	4-Kbyte Program Memory Start or Microprocessor Mode Memory Expansion
7000h	
7FFFh	Interrupt & Reset Vectors, Trap Vectors
8000h	Memory Expansion/External Memory
FFFFh	

<sup>†</sup> In devices with more than 256 Bytes of RAM, only the first 256 byte block can be used as registers/stack.

The following paragraphs describe each block of the memory map.

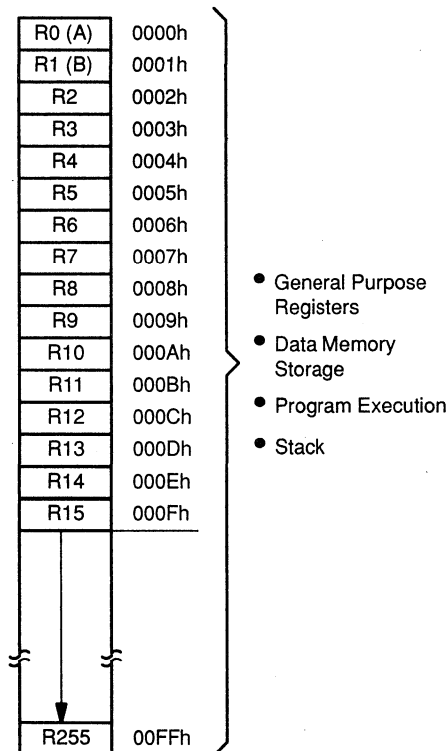
#### 3.3.1 Register File

The beginning addresses of the memory map (0000h – 00FFh) are on-chip RAM called the register file (RF). In devices with 128 bytes of RAM, the RF

has 128 memory locations treated as registers R0 through R127. In devices with 256 bytes of RAM, the RF has 256 memory locations treated as registers R0 through R255. If the device incorporates the PACT module with 128 bytes of Dual Port RAM, then the Dual Port RAM is mapped into memory location 0080h–00FFh. Any of this RAM not used by the PACT module can be used as registers or stack.

The first two registers, R0 and R1, are also called Register A and Register B, respectively. The memory addresses of these registers are given in Figure 3–5.

**Figure 3–5. Register File Addresses**



Locations within the RF address space may serve as either the CPU register file or general purpose read/write memory. Instructions can reside in and be executed from any location in the address space without restriction. The stack also occupies a portion of the register file.

Therefore, any location in the RF can be accessed by one of three ways:

- 1) Register access using the register number. For example,

```
MOV      A, R6      ;Move the contents of Register A to
                   ; Register R6.
```

```
MOV      R12, R200  ;Move the contents of Register 12 to
                   ; Register R200.
```

- 2) Stack access using the stack pointer. For example,

```
MOV      #5, B      ;Move the value 5 into Register B.
LDSP                      ;Move the contents of Register B to
                   ; the stack pointer.
PUSH A                    ;Increment stack pointer to 6.
                   ; Move contents of Register A to 0006h.
```

- 3) Normal memory access using 16-bit addresses. For example,

```
MOV      A, 0006    ;Move the contents of Register A to
                   ; memory location 0006h.
```

Access time to the register file, when used as a general purpose register, is a single system clock cycle. Any other access to the register file takes two clock cycles.

A reset operation has no effect on the contents of any memory location within the register file except for locations 0000h (Register A) and 0001h (Register B). Registers A and B are cleared in the beginning of the reset process.

The Halt, Idle, and Standby states have no effect on the contents of the register file or RAM.

RAM that is not in the first 256 bytes (0000h – 00FFh) is general purpose RAM, and is not considered part of the register file. Access to this RAM will take two clock cycles.

### 3.3.2 Peripheral File

The peripheral file (PF) is a set of memory-mapped registers which provide access to all internal peripheral modules, system-wide control functions, and EEPROM/EPROM programming control.

The PF includes 256 addresses in the memory map from 1000h – 10FFh. The PF is divided into 16 frames of 16 bytes each. Each peripheral module is allocated its own set of control registers. In addition, some frames are dedicated to specific functions.

The instruction set includes some instructions which access the peripheral file directly. These instructions designate the register by the number of the

file register relative to 1000h, preceded by P0 for a hexadecimal designator or P for a decimal designator. For example, the System Configuration Control Register 0 is located at address 1010h; its peripheral file hexadecimal designator is P010 and its decimal designator is P16.

Table 3–1 gives the address map for the peripheral file.

**Table 3–1. Peripheral File Address Map**

Frame No.	Address	Description	TMS370C		
			x1x	x3x	x5x
0	1000h	Reserved for factory test	—	—	—
1	1010h	System and EEPROM / EPROM control registers	YES	YES	YES
2	1020h	Digital I/O port control registers	YES	YES	YES
3	1030h	SPI registers	YES	NA	YES
4	1040h	Timer 1 registers	YES	NA	YES
		PACT registers	NA	YES	NA
5	1050h	SCI registers	NA	NA	YES
6	1060h	Timer 2 registers	NA	NA	YES
7	1070h	A-to-D registers	NA	YES	YES
8	1080h	Reserved	NA	NA	NA
9	1090h	Reserved	NA	NA	NA
10	10A0h	Reserved	NA	NA	NA
11	10B0h	Reserved	NA	NA	NA
12	10C0h	External Peripheral Control	NA	NA	YES
13	10D0h	External Peripheral Control	NA	NA	YES
14	10E0h	External Peripheral Control	NA	NA	YES
15	10F0h	External Peripheral Control	NA	NA	YES

NA – Not Available

Frame 0 of the peripheral file (memory addresses 1000h – 100Fh) is reserved for factory testing. The results of access to this frame are unpredictable.

Frame 1 (1010h – 101Fh) contains system configuration and control functions. It also contains registers for controlling EEPROM / EPROM programming. EEPROM / EPROM module control registers are described in Chapter 6.

Frame 2 (1020h – 102Fh) contains the Digital I/O Pin configuration/control registers. The individual functions controlled by these registers are described in Section 4.2.

Frames 3 through 7 are used by the internal peripherals. These peripherals and their control registers are described in the following chapters:

- SPI registers – Chapter 10
- Timer 1 registers – Chapter 7
- PACT registers – Chapter 12
- SCI registers – Chapter 9
- Timer 2 registers – Chapter 8
- A-to-D registers – Chapter 11

Frames 8 through 11 are reserved.

Frames 12 through 15 are available for external expansion of the peripheral file on devices that have bus expansion capability. These frames are located in external memory and accessed by the external address and data buses.

### 3.3.3 Data EEPROM Modules

The Data EEPROM modules are 256 and 512 byte arrays. Each 256 bytes is configured into 8 blocks of 32 bytes, and has an associated Write/Protect Register (WPR). Each block can be individually write protected by setting the appropriate bit in the WPR. This module can be programmed on an entire array, byte-wide, or single-bit basis. Read-access time for the EEPROM module is two system clock cycles. The 256 byte array is located at memory locations 1F00h through 1FFFh, with the WPR at location 1F00h. The 512 byte array is located at memory locations 1E00h through 1FFFh, with WPR's at locations 1E00h and 1F00h. Larger arrays will continue to grow toward the smaller memory addresses with WPR's located in the first byte of every 256 byte boundary.

Programming of the Data EEPROM array is controlled by the Data EEPROM Control Register (DEECTL) at memory address 101Ah (P01A) and the corresponding Write Protect Registers (WPR's). EEPROM programming commands are controlled through these registers. See Section 6.1.1.1 and Section 6.1.1.2 for more details on the WPR and DEECTL registers.

### 3.3.4 Program Memory

The program memory options available in the TMS370 family allow a wide selection of memory types; ROM, EPROM, or EEPROM, ranging in size from 4 to 16 Kbytes. The program memory is arranged as individually-addressable bytes in the memory map. Data may be read or code may be executed directly from these locations.

Memory addresses 7F9Ch through 7FBFh and 7FECh through 7FFFh are reserved for interrupt and reset vectors. Trap vectors, used with TRAP0



through TRAP15 instructions, are at addresses 7FC0h through 7FDFh. Table 3–2 gives the memory map for the reserved vector locations.

The program memory may be either ROM, EEPROM, or EPROM depending on the specific member of the TMS370 family. The differences are described in the paragraphs following Table 3–2.

**Table 3–2. Vector Address Map**

Address	Description	TMS370C x1x	TMS370C x3x	TMS370C x5x	No. of Bytes
7F9Ch	PACT INT 1 – 18	NA	YES	NA	36
7FC0h	Trap 0-15	YES	YES	YES	32
7FE0h	Reserved	YES	YES	YES	12
7FECh	A/D Converter	NA	YES	YES	2
7FEEh	Timer 2	NA	NA	YES	2
7FF0h	Serial Communications Interface TX	NA	NA	YES	2
7FF2h	Serial Communications Interface RX	NA	NA	YES	2
7FF4h	Timer 1	YES	NA	YES	2
7FF6h	Serial Peripheral Interface	YES	NA	YES	2
7FF8h	Interrupt 3	YES	YES	YES	2
7FFAh	Interrupt 2	YES	YES	YES	2
7FFCh	Interrupt 1	YES	YES	YES	2
7FFEh	Reset	YES	YES	YES	2

NA – Not Available

### 3.3.4.1 Program ROM Module (TMS370C0xx and TMS370C3xx devices only)

The Program ROM module consists of read-only memory which is programmed at the time of device fabrication. The present ROM module sizes are 4 K, 8 K, and 16 kilobytes. All accesses to the ROM module requires two system clock cycles.

#### Note:

All TMS370 family devices contain mask ROM space reserved for TI use only. This space includes locations 7FE0h through 7FEBh. This reserved area should not be used in the customer's software algorithm, nor should it be used during mask ROM/firmware development.

**The contents of the reserved locations are changed by TI.**

### 3.3.4.2 ROM-less Devices (TMS370C1xx and TMS370C2xx devices only)

The program memory for these devices must be off-chip. For the TMS370 to operate it must be in the microprocessor mode.

### 3.3.4.3 Program EEPROM Module (TMS370C8xx devices only)

The Program EEPROM module replaces the Program ROM for systems in prototype or small production runs. The module consists of 4 kilobytes of EEPROM (7000h – 7FFFh) and the necessary programming control logic.

The Program EEPROM Control Register (PEECTL) is located at memory location 101Ch in the peripheral file.

Read access to the Program EEPROM is performed as normal memory read cycles. Write cycles require a special sequence of events. This sequence is the same as that for the Data EEPROM. See Section 6.2.2 for a detailed discussion of programming the EEPROM Modules.

The EEPROM can be written to only when the microcomputer is operating under Write Protect Override (WPO), which is set by applying 12 volts to the MC pin.

### 3.3.4.4 Program EPROM Modules (TMS370C7xx devices only)

The Program EPROM modules replaces the Program ROM for systems in prototype or small production runs. The modules presently consist of 8 or 16 kilobytes of EPROM and the necessary programming control logic.

The Program EPROM Control Register (EPCTL) is located at memory location 101Ch (P01C) in the peripheral file.

Read access to the Program EPROM is performed as normal memory read cycles. Write cycles require a special sequence of events. See Section 6.3.2 for a detailed discussion of programming the EPROM Modules.

The EPROM can only be written to when  $V_{PP}$  is applied to the MC/EPV<sub>PP</sub> pin and the VPPS (EPCTL.6) bit is set. When  $V_{PP}$  is applied to the MC/EPV<sub>PP</sub> pin all on-chip EEPROM is in Write Protect Override (WPO) mode regardless of the state of the VPPS bit. This allows the EPROM to be protected while the EEPROM is in WPO.

### 3.4 Memory Operating Modes

Devices that have the Memory Bus Expansion can operate in one of two major memory modes.

- Microcomputer modes
  - microcomputer single-chip mode
  - microcomputer with external expansion
- Microprocessor modes
  - microprocessor without internal program memory
  - microprocessor with internal program memory

Devices that do not have the Memory Bus Expansion can operate only in the microcomputer, single-chip mode. Table 3–3 shows the presently available devices and the modes that they can operate in.

**Table 3–3. Memory Modes Available**

Mode	Device TMS370C			
	x1x	x3x	15x, 25x	05x, 35x, 75x, 85x
μC Single Chip	Yes	Yes	No	Yes
μC External Expansion	No	No	No	Yes
μP without Internal Program Memory	No	No	Yes	Yes
μP with Internal Program Memory	No	No	No	Yes

For devices that have the Memory Bus Expansion, the basic microcomputer and microprocessor operating modes are selected by the voltage level applied to the dedicated MC pin when the  $\overline{\text{RESET}}$  pin goes inactive (high).

If the MC pin is low when the  $\overline{\text{RESET}}$  signal goes high then the processor enters the microcomputer mode. If the MC pin is high when the  $\overline{\text{RESET}}$  signal goes high, then it enters the microprocessor mode. Changing the MC pin alone will not change the memory mode. To change memory operating mode, change the MC pin and then reset the device.

Applying 12 volts to the MC pin *after* reset forces the device to enter the Write Protect Override (WPO) mode.

**Note:**

If 12 volts is applied to the MC pin when the  $\overline{\text{RESET}}$  pin goes from low to high, the results are unpredictable.

3

If the processor resets into a microcomputer mode, the software can change the internal system configuration registers to select the desired memory expansion configuration. Part of this configuration setup involves Digital I/O Port D. Each pin of Port D can be programmed to serve one of three purposes: Digital I/O, Function A signal, or Function B signal. Function A includes chip select signals which may be used in the microcomputer mode with External Memory Expansion. Function B includes signals used in either the microcomputer or the microprocessor modes to access external memory chips.

Each of these modes are described in the following paragraphs.

### 3.4.1 Microcomputer Mode Single-Chip

In the microcomputer mode single chip, a TMS370 device functions as a self-contained microcomputer with all memory and peripherals on the chip. There is no external address or data bus in this mode, which allows more pins (used for the external buses in other modes) to be programmed as input/output pins. This mode maximizes the general purpose I/O capability for real-time control applications. Figure 3-6 shows a memory map for the microcomputer mode single chip.

During reset the MC pin must remain at a low level in order to successfully enter the microcomputer mode. While operating in the single-chip mode, external circuitry may place 12 volts on the MC pin to enter the Write Protect Override (WPO) mode to alter protected EEPROM.

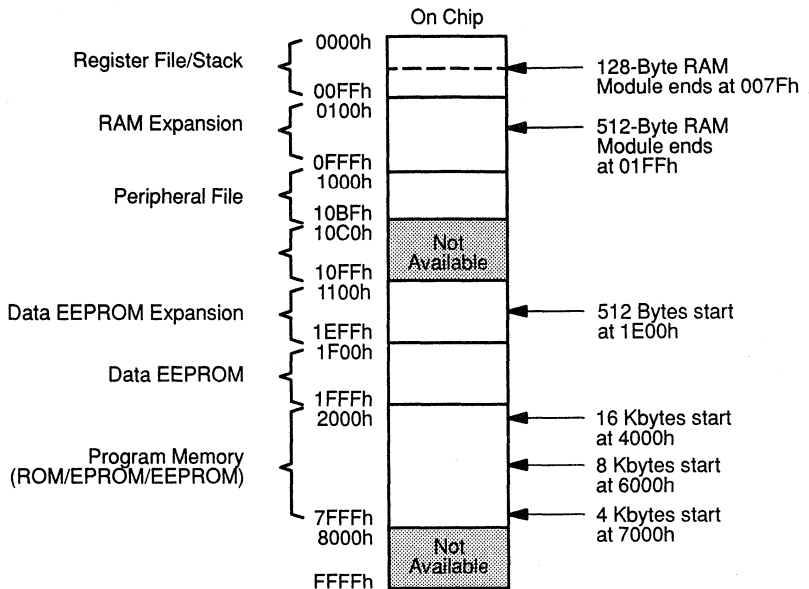
To put a TMS370 device into the microcomputer mode, single chip:

- 1) Place a low logic level on the MC pin.
- 2) Take the  $\overline{\text{RESET}}$  pin active low, then return  $\overline{\text{RESET}}$  to its inactive high state.

**Note:**

The preceding procedure must be followed for devices that do not have the Memory Bus Expansion, even though they operate only in the microcomputer mode single chip.

Figure 3–6. Microcomputer, Single Chip Mode



### 3.4.2 Microcomputer Mode with External Expansion (All devices with Bus Expansion and Internal Program Memory)

The microcomputer mode also supports bus expansion to external memory or peripherals, while all on-chip memory (register file, ROM, and EEPROM) remains active. Digital I/O ports, under the control of their associated port control registers, become the external buses as follows:

- ❑ Port A: 8-bit data bus
- ❑ Port B and C: 16-bit address bus
- ❑ Port D: 8-bit control bus

If it is not necessary to use the entire address, data, or control bus, then each unused pin can be individually programmed as a general purpose input/output pin. These bits are programmed by setting the Digital I/O control registers in the peripheral file (see Section 4.2 for further information on programming I/O pins).

The address bus and data bus are non-multiplexed, eliminating the requirement for an external address/data latch, thereby lowering system cost. External interface decode logic can be reduced further by using the precoded chip select outputs. The Port D outputs can be programmed on a pin-by-pin

basis to provide direct memory/peripheral chip selection or chip enable functions.

Each Port D pin can be individually set to Function A, Function B or general purpose I/O. When Port D is set up to drive the chip selection signals (Function A), a memory access to any location between 2000h and 3FFFh, activates pins  $\overline{\text{CSE1}}$  and  $\overline{\text{CSE2}}$ . Typically, an application that uses both  $\overline{\text{CSE1}}$  and  $\overline{\text{CSE2}}$  sets one as the active chip-select function and sets the other as a general-purpose high-level output. Up to 16 kilobytes of external memory can be mapped into this address space.

Similarly, a memory access to any location between 8000h and FFFFh activates  $\overline{\text{CSH1}}$ ,  $\overline{\text{CSH2}}$ , and  $\overline{\text{CSH3}}$  if enabled by the appropriate port control registers. The  $\overline{\text{CSH1}}$ ,  $\overline{\text{CSH2}}$ , and  $\overline{\text{CSH3}}$  signals can be used as memory bank select signals under software control. As a result, up to 96 kilobytes of external memory can be mapped into the 32-kilobyte logical address space of 8000h – FFFFh as shown in Figure 3–7.

The  $\overline{\text{CSPF}}$  pin is activated, if enabled, during accesses to the upper 4 frames (memory addresses 10C0h – 10FFh) of the peripheral file. This signal can be used as a chip select for external expansion of the peripheral file. These chip select control lines allow access to more than 112 kilobytes of external memory.

The RAM expansion area, Data EEPROM Expansion Area, and Internal Memory Expansion Area are not available for external accesses.

---

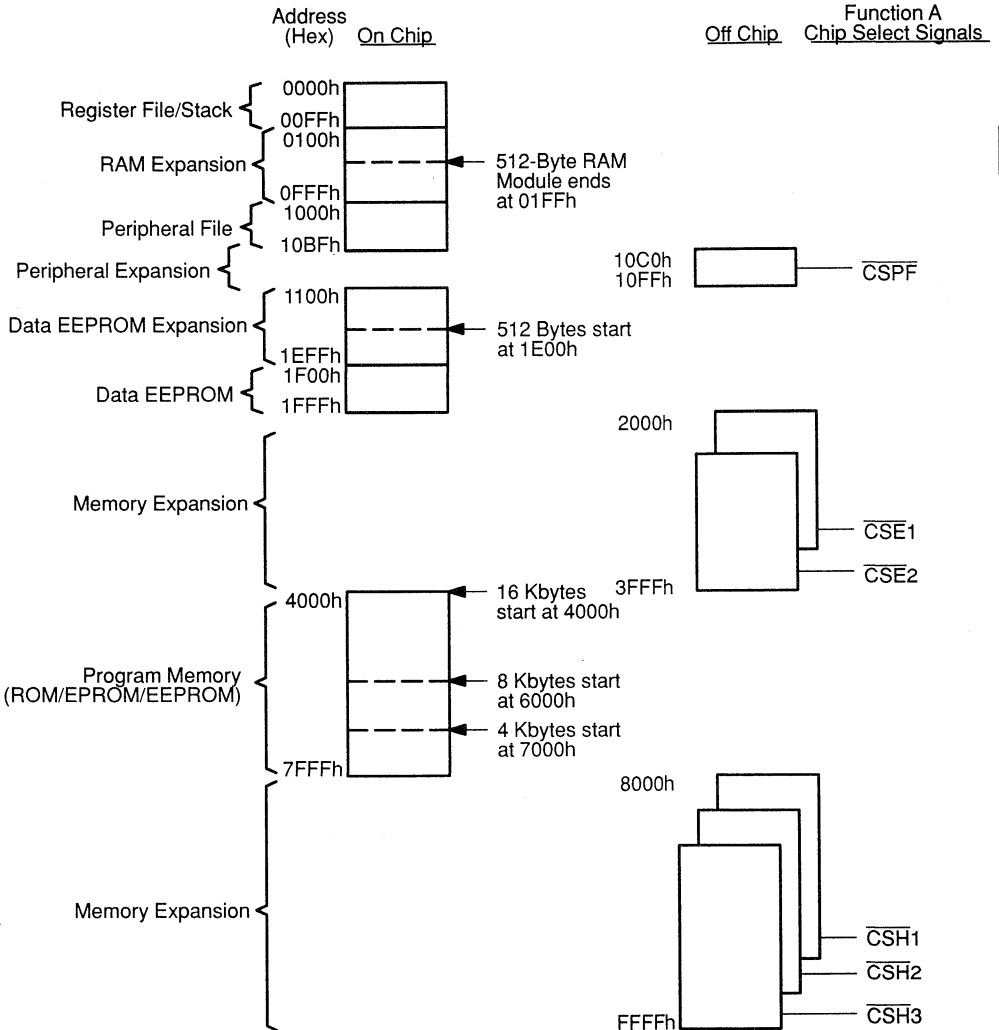
**Note:**

Applications that use more than one chip-select signal for the same address should set the unused chip-selects (i.e., chip-selects not currently used to select memory banks) to general-purpose high-level outputs.

---

3

**Figure 3–7. Microcomputer Mode with Function A Expansion**

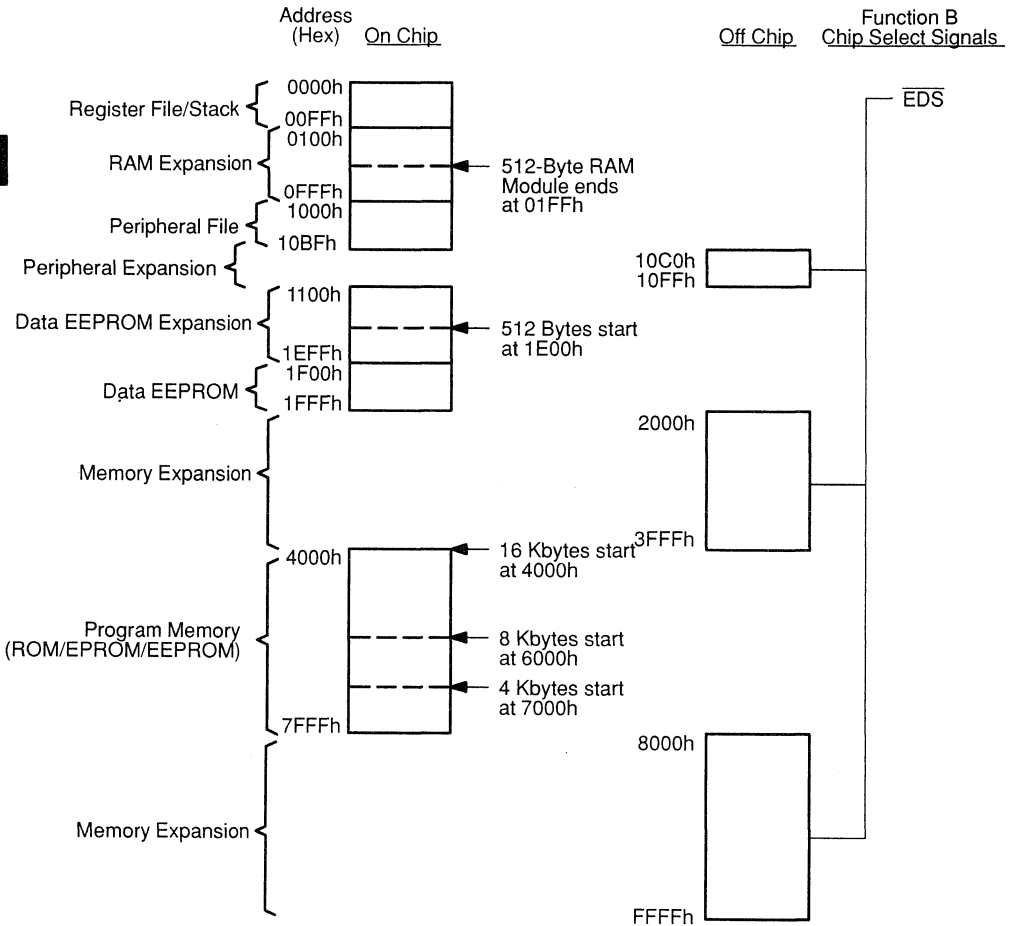


3

All predecoded chip selects have the same timing as the External Data Strobe ( $\overline{\text{EDS}}$ ) signal (see Chapter 16, Electrical Specifications).  $\overline{\text{EDS}}$  is a Function B (microprocessor mode) signal which goes low whenever an access to external memory is made. Figure 3–8 shows a memory map for the microcomputer mode with Function B Expansion.

**Figure 3–8. Microcomputer Mode with Function B Expansion**

3



See Section 4.2 for a description of the Digital I/O port control registers and how the chip select signals are enabled.

To put a device into the microcomputer mode with External Expansion, the following steps must be followed (device **must** have Bus Expansion):

- 1) Place a low logic level on the MC pin.
- 2) Take the  $\overline{\text{RESET}}$  pin active low, then return  $\overline{\text{RESET}}$  to its inactive high state.
- 3) Program the Digital I/O registers to select the chip select or control signals needed (Function A or Function B).



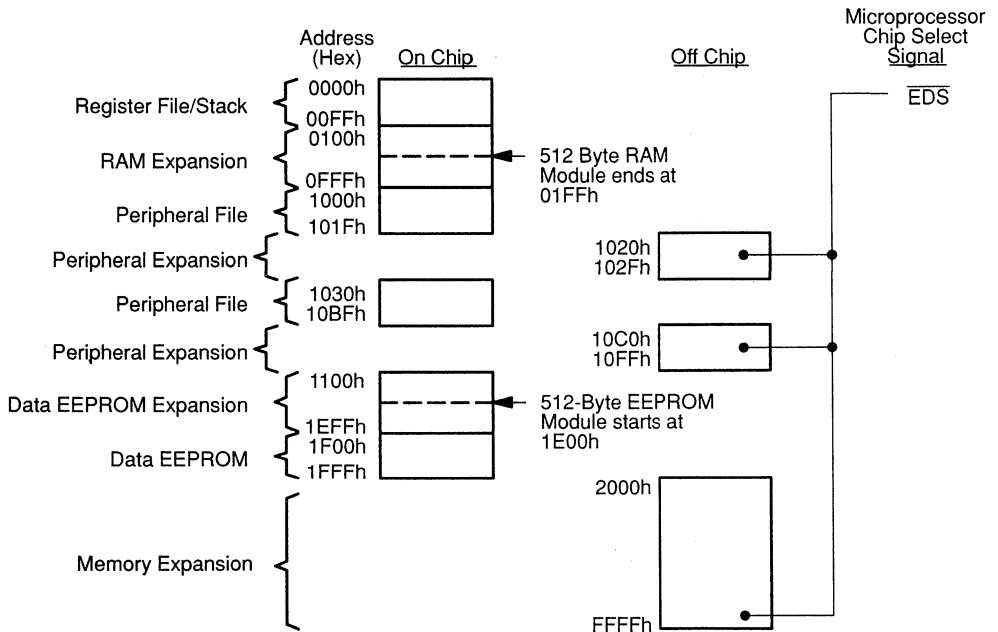
### 3.4.3 Microprocessor Mode without Internal Memory (Bus Expansion Devices Only)

When a device is activated in the microprocessor mode, the register file and data EEPROM remain active, but the on-chip Program ROM or EEPROM is disabled. The  $\overline{EDS}$  signal goes low when a memory access is made to addresses 1020 – 102F, 10C0h – 10FFh, and 2000h – FFFFh. The program area, the reset vector, interrupt vectors, and trap vectors must be located in off-chip memory locations.

When a device is reset into the microprocessor mode, the Digital I/O, Port D registers are set to Function B expansion memory control signals. The chip-select signals are not available in Function B. Ports B and C are set up as the external address bus and Port A is set up to be the external data bus. Software cannot change the Digital I/O configuration.

Figure 3–9 shows a memory map for the microprocessor mode.

**Figure 3–9. Microprocessor Mode without Internal Memory**



To put a device into the microprocessor mode without Internal Memory:

- 1) Place a high logic level on the MC pin.
- 2) Take the  $\overline{\text{RESET}}$  pin active low, then return  $\overline{\text{RESET}}$  to its inactive high state.

3

### 3.4.4 Microprocessor Mode with Internal Program Memory (Bus Expansion Devices Only)

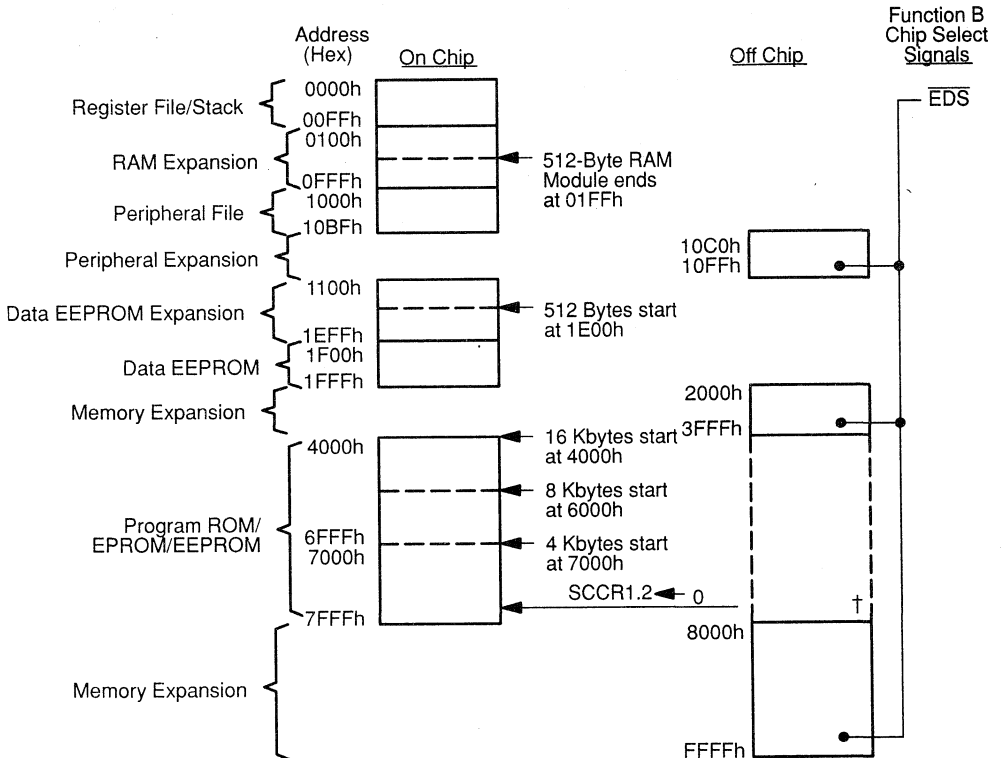
Once in microprocessor mode, the internal program memory can be re-enabled by clearing the MEMORY DISABLE bit (SCCR1.2). This mode is exactly the same as the microprocessor mode without Internal Memory except that when the internal memory is enabled the EDS signal is no longer active on memory access to 1020h–102Fh and 4000h–7FFFh. Memory accesses from 4000h–7FFFh will access internal program memory. The actual amount of program memory available depends on the device.

In this mode accesses to 1020h–102Fh are not valid for external memory nor for the internal port control registers. This peripheral frame should not be used in this mode.

To use this mode there must be external memory implemented at 7FFEh–7FFFh to contain the reset vector. This memory can be switched in and out with the internal memory by clearing and setting the memory disable bit.

Figure 3–10 shows a memory map for the microprocessor mode with Internal Program Memory.

Figure 3–10. Microprocessor Mode with Internal Program Memory



† After reset, until SCCR1.2 is cleared by the program.

To put a device into the microprocessor mode with Internal Program Memory the following steps must be followed:

- 1) Place a high logic level on the MC pin.
- 2) Take the  $\overline{\text{RESET}}$  pin active low, then return  $\overline{\text{RESET}}$  to its inactive high state.
- 3) The CPU reads the reset vectors from external memory (7FFEh/7FFFh). The program pointed to by the vectors must include code to clear the MEMORY DISABLE bit (SCCR1.2) to enable the internal memory. The internal program memory is now available.

**Note:**

Once the MEMORY DISABLE bit is cleared, the external memory at 1020h–102Fh and 4000h–7FFFh are no longer available to the processor.

**3 3.4.5 Memory Mode Summary**

Table 3–4 summarizes the features of each Memory Mode and gives the procedure to activate the TMS370 device into each mode. Figure 3–11 gives the memory maps of the four modes.

**Table 3–4. Operating Mode Summary**

Feature	μComputer Single Chip	μComputer w/Expanded Memory	μProcessor w/Internal Memory	μProcessor
Device	All TMS370s with Internal Program Memory	Devices with Bus Expansion and Internal Program Memory	Devices with Bus Expansion and Internal Program Memory	Devices with Bus Expansion
Memory Address Range 4000h – 7FFFh	Internal	Internal	Internal and External	External
Ports A,B,C,D	Digital I/O	Digital I/O Function A † Function B ‡	Function B ‡	Function B ‡
Predecoded CS (Chip Selects)	No	Optional	No	No
Procedure to enter the mode	1. Place logic 0 on the MC pin 2. Take the RESET pin active low, then release RESET	1. Place logic 0 on the MC pin 2. Take the RESET pin active low, then release RESET 3. Set Digital I/O registers to Function A*/B**	1. Place logic 1 on the MC pin 2. Take the RESET pin active low, then release RESET 3. Enable internal memory (Clear SCCR1.2)	1. Place logic 1 on the MC pin 2. Take the RESET pin active low, then release RESET

† Function A: Port D = chip select signals  $\overline{CSE1}$ ,  $\overline{CSE2}$ ,  $\overline{CSH1}$ ,  $\overline{CSH2}$ ,  $\overline{CSH3}$ , and  $\overline{CSPF}$  (see Section 4.2).

‡ Function B: Port D = expansion memory control signals  $\overline{OCF}$ ,  $\overline{EDS}$ , and  $\overline{WAIT}$  (see Section 4.2).

Figure 3–11. Memory Operating Modes

3

	Microcomputer Single Chip Mode	Microcomputer With External Expansion	Microprocessor With Internal Program Memory	Microprocessor Mode
0000h	On Chip	On Chip	On Chip	On Chip
00FFh 0100h	On Chip Expansion	On Chip Expansion	On Chip Expansion	On Chip Expansion
0FFFh 1000h	On Chip	On Chip	On Chip ‡	On Chip ‡
10BFh 10C0h	Not Available	External †	External	External
10FFh 1100h	On Chip Expansion	On Chip Expansion	On Chip Expansion	On Chip Expansion
1EFFh 1F00h	On Chip	On Chip	On Chip	On Chip
1FFFh 2000h	Not Available	External †	External	External
3FFFh 4000h	On Chip Expansion	On Chip Expansion	On Chip Expansion	External
6FFFh 7000h	On Chip	On Chip	On Chip	External
7FFFh 8000h	Not Available	External †	External	External
FFFFh				

† Precoded Chip Select outputs available on External Expansion Bus.

‡ 1020h–102Fh External.



Introduction	1
Assembly Language Instruction Set	13
TMS370 Family Devices	2
Design Aids	14
CPU and Memory Organization	3
Development Support	15
System and Digital I/O Configuration	4
Electrical Specifications	16
Interrupts and System Reset	5
Customer Information	17
EEPROM Modules	6
Appendices	A-H
Timer 1 Module	7
Timer 2 Module	8
Serial Communications Interface (SCI) Port	9
Serial Peripheral Interface (SPI) Module	10
Analog-to-Digital Converter Module	11
TMS370 Programmable Acquisition and Control Timer	12





# System and Digital I/O Configuration

---

---

---

---

---

This chapter discusses system and I/O configuration. Features and options are described, as well as the registers that control the configuration. Examples of how to set specific configurations are also given. This chapter covers the following topics:

Section	Page
4.1 System Configuration .....	4-2
4.2 Digital I/O Configuration .....	4-15

## 4.1 System Configuration

The system configuration is controlled and monitored by the first three registers of peripheral file Frame 1. These registers' names, designations, and peripheral file register number (PF) are:

Name	Designation	Address	PF
System Control and Configuration Register 0	SCCR0	1010h	P010
System Control and Configuration Register 1	SCCR1	1011h	P011
System Control and Configuration Register 2	SCCR2	1012h	P012

These registers are shown in Figure 4–1. The "PF" numbers are used by peripheral file instructions, for example `MOV #00h, P010`.

**Figure 4–1. System Configuration and Control Registers**

ADDR	PF	Bit 7	Bit 6	Bit 5	Bit 4	Bit 3	Bit 2	Bit 1	Bit 0	
1010h	P010	COLD START	OSC POWER	PF AUTO WAIT	OSC FLT FLAG	MC PIN WPO	MC PIN DATA	—	μP/μC MODE	SCCR0
1011h	P011	—	—	—	AUTOWAIT DISABLE	—	MEMORY DISABLE	—	—	SCCR1
1012h	P012	HALT/STANDBY	PWRDWN/IDLE	OSC FLT RST ENA	BUS STEST	CPU STEST	OSC FLT DISABLE	INT1 NMI	PRIVILEGE DISABLE	SCCR2

The bits shown in Figure 4–1 in shaded boxes are Privilege Mode bits, that is, they can only be written to in the Privilege Mode.

### 4.1.1 Privilege Mode

The TMS370 architecture allows you to configure the system and peripherals by software to meet the requirements of a variety of applications. The Privilege Mode of operation ensures the integrity of the system configuration once defined for an application.

Following a hardware reset, the processor operates in the Privilege Mode. In this mode, peripheral file registers have unrestricted read/write access. The application program may configure the system during the initialization sequence following reset. As the last step of a system initialization, set the PRIVILEGE DISABLE bit (SCCR2.0) to enter the nonprivilege mode and prevent changes to specific control bits within the peripheral file.

Table 4–1 shows the system configuration bits which are write-protected during the nonprivilege mode. These bits should be configured by software prior to exiting the Privilege Mode.

**Table 4–1. Privilege-Mode Configuration Bits**

Register	Bit
SCCR0	OSC POWER
SCCR1	MEMORY DISABLE AUTOWAIT DISABLE
SCCR2	PRIVILEGE DISABLE POWERDOWN/IDLE HALT/STANDBY INT NMI OSC FLT DISABLE OSC FLT RST ENA
SPIPRI	SPI PRIORITY
SCIPRI	SCI TX PRIORITY SCI RX PRIORITY
T1PRI	T1 PRIORITY
T2PRI	T2 PRIORITY
ADPRI	AD PRIORITY
PACTPRI	PACT GROUP 1 PRIORITY PACT GROUP 2 PRIORITY PACT GROUP 3 PRIORITY PACT STEST PACT MODE SELECT PACT WD PRESCALE SELECT 1 PACT WD PRESCALE SELECT 2
PACTSCR	FAST MODE SELECT PACT PRESCALE SELECT 3 PACT PRESCALE SELECT 2 PACT PRESCALE SELECT 1 PACT PRESCALE SELECT 0

The only way to change the privilege bits after leaving the Privilege Mode is to reset the processor and then program the control registers. The write protect override (WPO) used for the EEPROM, has no effect on the privileged bits.

Privilege Mode has no effect on Timer 1 Watchdog bits. These bits are protected in a separate manner.

### 4.1.2 Oscillator Fault

The processor contains a system of circuits to monitor the oscillator operation and to detect and contain major oscillator problems. This enhances processor and system reliability and aids in system recovery caused by a temporary fault. Programmable bits allow the user the option of incorporating or deleting some features of these circuits to match the application.

The circuit stops the processor whenever circuitry detects an out of range oscillator operation. The Oscillator Fault Detection circuitry consists of:

- 1) Amplitude detector: Detects if the oscillator signal has a proper voltage level.
- 2) Frequency detector: Senses when the oscillator frequency goes too low. The oscillator fault detection circuit will always trigger below 20 KHz and never above 500 KHz.

The oscillator circuitry is designed to delay operation of the device until a stable clock signal is received. This protects the part against slow crystal startup times coming out of a halt mode or after an oscillator fault when the input clock may not be operating at the correct voltage range. The circuitry holds device operation until the input clock signal is within the required voltage range.

The Oscillator Fault Reset Enable bit (OSC FLT RST ENA) allows the user to determine what action the processor will take when the oscillator goes out of range. When active, the processor pulls the RESET pin low for at least eight cycles causing external devices to reset along with the processor. When inactive, the processor enters a Pseudo-halt state and waits for a reset.

The OSC FLT RST ENA bit defaults to the active state after a reset. This allows the processor to generate reset pulses until the oscillator operates within the correct range.

After Reset, the program can check the Oscillator Fault Flag (OSC FLT FLAG) along with the Cold Start flag and Watchdog Reset flag to help determine the source of the reset. A reset does not clear these flags.

Three bits control and monitor the operation of the Oscillator Fault circuitry: OSC FLT FLAG, OSC FLT DISABLE and OSC FLT RST ENA. These bits are described further in Section 4.1.5.

### 4.1.3 Automatic Wait States

If an application system uses peripherals or expansion memory with slower access time than the TMS370 processor, wait states are required. Other microprocessors require complex additional circuitry, but the TMS370 series provides for the automatic addition of wait states which can slow the processor's access time to a compatible period.

In addition, the TMS370 series has a WAIT pin which can hold the processor in a wait state indefinitely. Two bits control the insertion of the Automatic wait state: the PF AUTO WAIT bit and the AUTOWAIT DISABLE bit. The PF AUTO WAIT bit controls the higher four frames (64 bytes) of the periph-

eral file so that these frames can access off-chip peripherals. The AUTO-WAIT DISABLE controls all other external memory.

When the AUTOWAIT DISABLE bit equals 1, any access to **EXTERNAL** memory (excluding the PF file) takes 2 system clock cycles to complete. When AUTOWAIT DISABLE equals 0, the access takes 3 cycles. The reset value of this bit selects the slower 3-cycle access.

When the PF AUTO WAIT bit equals 1, memory access to the **EXTERNAL** peripheral files takes 4 system clock cycles. This bit does not affect the accesses to the internal registers. When the PF AUTO WAIT equals 0, the memory is treated like any external memory and the AUTOWAIT DISABLE bit selects the number of cycles per access as either 2 or 3 cycles. Table 4–2 summarizes the effects of the Wait State Control bits.

4

**Table 4–2. Wait State Control Bits**

Wait State Control Bits		No. of Clock Cycles per Access	
PF Auto Wait (SCCR0.5)	Autowait Disable (SCCR1.4)	PF File	External Memory
0	0	3	3
0	1	2	2
1	0	4	3
1	1	4	2

An external device can pull the  $\overline{\text{WAIT}}$  input pin low and cause the processor to wait an indefinite number of clock cycles for its data. When the wait line is released, the processor resynchronizes with the rising edge of the clock out signal and continues with the program. The  $\overline{\text{WAIT}}$  pin is sampled only during **EXTERNAL** memory cycles.

**Note:**

When constructing an application circuit with expansion memory, do not forget to connect an unneeded  $\overline{\text{WAIT}}$  line to Vcc.

### 4.1.4 Powerdown and Idle Modes

Each TMS370 device has two low-power modes and an idle mode. The powerdown modes reduce the operating power by reducing or stopping the activity of various modules whenever processing is not needed. The processor has two types of powerdown modes, the halt mode and the standby mode. Bits 6 and 7 of SCCR2 select the halt, standby, or idle modes.

The **standby** mode stops the internal clock in every module except the Timer 1 module. The Timer 1 module continues to run and can bring the processor out of the standby mode. In devices with the PACT module, only the default timer and the first command are active in standby mode.

The **halt** mode stops the internal clock which stops processing in all the modules providing the lowest power consumption.

The **idle** mode (which is not a low-power mode) is a state which waits for the next interrupt.

Executing an IDLE instruction causes the processor to enter one of the two powerdown modes or the simple idle mode depending on SCCR2.6 and SCCR2.7. The powerdown and idle mode selection bits are summarized in Table 4-3.

**Table 4-3. Powerdown/Idle Control Bits**

Powerdown Control Bits		Mode Selected
Pwrdown/Idle (SCCR2.6)	Halt/Standby (SCCR2.7)	
1	0	Standby
1	1	Halt
0	X †	Idle

† don't care

These modes and the methods of exiting the modes are discussed further in Section 4.1.4.1 and Section 4.1.4.2.

In the standby and halt mode, the following information is retained:

- ☐ The CPU registers:
  - PC
  - Status
  - Stack pointer
- ☐ The contents of the RAM
- ☐ The Digital output data registers
- ☐ The Digital output ports remain active

- ❑ Control and status registers of all the modules including the timer contents and the watchdog counter.

If the Serial Peripheral Interface (SPI) or Serial Communications Interface (SCI) is in the process of receiving or transmitting data, that data may be lost. The results of an A-to-D conversion or an EEPROM write in process will be invalid when a powerdown mode is entered.

The watchdog mode should be used with caution in the powerdown modes since the watchdog stops counting in both powerdown modes. If the program executes an IDLE instruction without the interrupts enabled (described in Section 4.1.4.1 and Section 4.1.4.2), then only a reset can start the processor running again.

4

#### 4.1.4.1 Standby Mode

The standby mode uses less power than the normal operating mode but more than the halt mode. The standby mode stops the clocks to every module except the Timer 1 module or the PACT module. These modules can bring the processor out of this low power mode if the interrupts are enabled. To enter this mode set the PWRDWN/IDLE bit (SCCR2.6) and clear the HALT/STANDBY bit (SCCR2.7). The next execution of an IDLE instruction causes the processor to enter the standby mode.

The processor can exit the standby mode by one of the following four methods.

- ❑ Reset
- ❑ External Interrupt 1, 2, or 3 (if enabled)
- ❑ Low level on the SCIRXD pin if, the SCI RX interrupt and receiver are enabled (described in Chapter 9)
- ❑ Timer 1 or PACT's first command/definition entry interrupt if enabled

For additional standby mode power savings, see Section 4.1.4.3.

#### 4.1.4.2 Halt Mode

The halt mode stops all internal operations and clocks (including Timer 1 and PACT counter) and uses the least power of the low power modes. Timer 1 can not bring the processor out of this low-power mode. To select the halt mode, set the PWRDWN/IDLE bit (SCCR2.6) and the HALT/STANDBY bit (SCCR2.7); then execute an IDLE instruction.

The processor can exit the halt mode by the following three methods.

- ❑ Reset
- ❑ External Interrupt 1, 2, or 3 if enabled
- ❑ Low level on the SCIRXD pin, if the SCI RX interrupt and receiver are enabled (described in Chapter 9)

### 4.1.4.3 Using Interrupts to Exit from Powerdown Modes

The user should be aware of several items when using an interrupt to exit a halt powerdown mode.

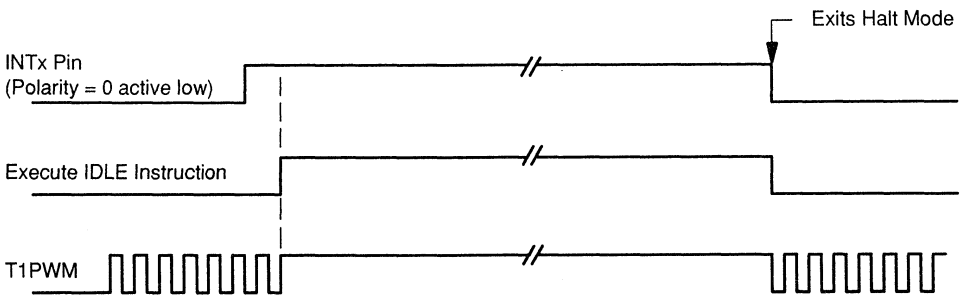
Interrupts enabled during halt mode are level sensitive and not edge sensitive. This means that the interrupt must be at the inactive level when entering halt mode. The processor will exit the halt mode when the interrupt goes from the inactive level to the active level. Bit 2 in the interrupt control register determines the active and inactive levels. If the halt mode is entered with the interrupt at an active level, the processor will exit the halt mode and enter the idle mode. When the selected interrupt edge is detected the program will continue.

If this condition exists and the part uses the watchdog, then the watchdog can reset while the program is waiting and unable to service the watchdog in the normal power idle mode.

The same considerations apply exiting halt mode using the SCIRXD pin. The processor will exit halt mode anytime an enable SCI receiver and pin detect a low level on SCIRXD.

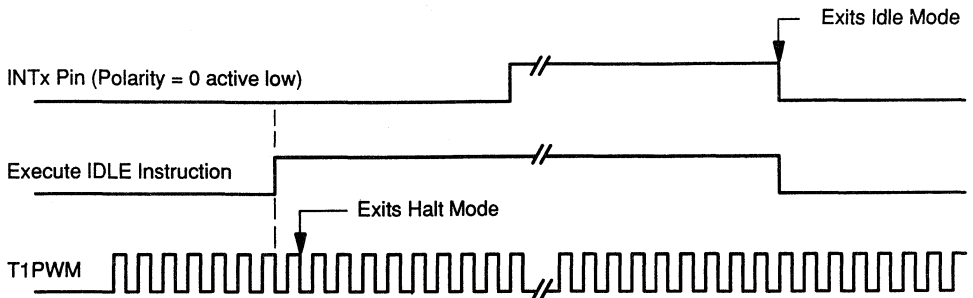
4

**Figure 4–2. Correct Method to Enter Halt Mode**





**Figure 4–3. Improper Method to Enter Halt Mode**



4

#### 4.1.4.4 Oscillator Power Bit

The OSC POWER bit (SCCR0.6) allows additional standby mode power savings. When in effect, this feature reduces the oscillator drive current and disables the oscillator fault detection circuitry. The OSC POWER bit can be used effectively between 2 MHz and 12 MHz. If the oscillator frequency is greater than 12 MHz, this bit must be cleared. For power reduction specifications, see Chapter 16, Electrical Specifications.

### 4.1.5 System Control Registers

Each System Control register is summarized in the following charts with definitions of each control bit.

#### 4.1.5.1 System Control and Configuration Register 0 (SCCR0)

**System Control and Configuration Register 0 (SCCR0)**  
[Memory address – 1010h]

BIT#-	7	6	5	4	3	2	1	0
P010	COLD START	OSC POWER	PF AUTO WAIT	OSC FLT FLAG	MC PIN WPO	MC PIN DATA	—	μP/μC MODE
	RC-*	RP-0	RW-0	RW-0	R-0	R-*		R-*

R = Read, W = Write, P = Write only in Privilege mode, C = Clear only,  
-n = Value after reset, \* = see bit description

- Bit 0 - **μP/μC MODE.** Microprocessor/Microcomputer Mode  
This bit indicates the current operating mode (as described in Section 3.4).  
0 = Currently operating in microcomputer mode.  
1 = Currently operating in microprocessor mode.
- Bit 1 - Reserved. Read data is indeterminate.
- Bit 2 - **MC PIN DATA.** Mode Control Pin Data.  
This bit shows the current status of the MC pin.  
0 = Voltage on the MC pin is a logic 0 level.  
1 = Voltage on the MC pin is a logic 1 level.
- Bit 3 - **MC PIN WPO.** Mode Control Pin Write Protect Override status.  
This bit indicates whether or not the voltage on the MC pin is enough for WPO functions. (If this bit is set, then bit 2 is also set.)  
0 = Voltage on the MC pin is not enough to override write protection.  
1 = Voltage on the MC pin is enough for write-protect operation override. Protected bits in Data EEPROM and Program EEPROM can now be written to. Override voltage is nominally 12 volts.
- Bit 4 - **OSC FLT FLAG.** Oscillator Fault Flag.  
This flag is reset upon an initial power-up reset. A reset under power does not affect this flag. Therefore, this bit can be be polled to determine the source of a reset.  
0 = No oscillator fault found.  
1 = Oscillator Fault found. Oscillator period is now or was out of correct operating range. The Oscillator fault detect circuit always triggers below 20 KHz and never above 500 KHz.

- Bit 5 - **PF AUTO WAIT.** Peripheral File Automatic Wait Cycle.
- 0 = Any access to the peripheral file will take 2 system clock cycles with no System Auto Wait (bit 4 of SCCR1=1), or 3 system clock cycles with the System Auto Wait on (bit 4 of SCCR1=0). (See Section 4.1.3, page 4-4.)
  - 1 = Any access to the upper 4 frames of the peripheral file (address 10C0h to 10FFh) will take 4 system clock cycles to complete. This eases interface requirements for peripheral devices slower than the TMS370 processor. Normal full speed operation consists of 2 system clock cycles per access.
- Bit 6 - **OSC POWER.** Oscillator Power.
- This bit controls an oscillator power reduction feature. When this feature is in effect, the oscillator drive current is reduced and the oscillator fault detection circuitry is powered down. Current reduction is most useful in the standby mode. However, when this bit is set during normal operation, the operating mode power consumption may be slightly reduced. When operating in the halt mode, this bit has no effect since the oscillator is not active. This feature is effective up to a 12 MHz maximum oscillator frequency. If the oscillator frequency is greater than 12 MHz, this bit must be cleared. For power reduction specifications, see Chapter 16, Electrical Specifications.
- 0 = no oscillator drive current reduction.
  - 1 = oscillator drive current reduction.
- Bit 7 - **COLD START.**
- This bit does not change during a reset under power.
- 0 = No power-up reset occurred since last writing a 0 to this bit.
  - 1 = Power-up reset has occurred since last writing a 0 to this bit, indicating one cause of a system reset. The Watchdog Overflow Flag and the Oscillator Fault Flag indicate two other causes of a system reset. A program may take different actions depending upon the source of the reset.
- Only writing a 0 to this bit can clear the COLD START flag.*

### 4.1.5.2 System Control and Configuration Register 1 (SCCR1)

System Control and Configuration Register 1 (SCCR1)  
[Memory Address – 1011h]

BIT#-	7	6	5	4	3	2	1	0
P011	—	—	—	AUTO-WAIT DISABLE	—	MEMORY DISABLE	—	—
				RP-0		RP-*		

R = Read, P = Write only in Privilege state, -n = Value after reset, \* = see bit description

Bits 0,1,3,5,6,7 - Reserved. Read data is indeterminate.

Bit 2 - **MEMORY DISABLE.**

This bit enables or disables the internal program memory (memory addresses 4000h—7FFFh). This bit does not affect Data EEPROM or internal RAM. RESET initializes this bit to the state of the MC pin. Changes to this bit can occur only in the privilege state.

0 = Enable internal Program Memory and access internal memory at these locations. The  $\overline{EDS}$  memory signal will not appear during access to locations 4000h–7FFFh and 1020h–102Fh. These ranges are accessed as off-chip memory.

1 = Disable internal Program Memory and make all memory accesses to these locations access external memory. An operation on these locations generates an external memory bus cycle with the  $\overline{EDS}$  memory signal validating the access. This bit disables the Program EEPROM and EPROM control registers, PEECTL / EPCTL registers (described in Sections 6.2 and 6.3), if applicable and 1020h–102Fh. These ranges are accessed as off-chip memory.

Bit 4 - **AUTOWAIT DISABLE.** Automatic Wait State Disable.

This bit, which is cleared at reset, causes an extra cycle to be added to all external bus accesses in order to accommodate slower memory.

0 = Enable the Autowait feature and make external bus access 3 system clock cycles long.

1 = Disable the Autowait feature and make external bus access 2 system clock cycles long.

Changes to this bit can occur only in the privilege state. If the Peripheral File Autowait bit in SCCR0 is set, external peripheral file access takes 4 system clock cycles regardless of the AUTOWAIT DISABLE bit.

4

### 4.1.5.3 System Control and Configuration Register 2 (SCCR2)

System Control and Configuration Register 2 (SCCR2)  
[Memory Address – 1012h]

BIT#-	7	6	5	4	3	2	1	0
P012	HALT/ STANDBY	PWR- DWN/ IDLE	OSC FLT RST ENA	BUS STEST	CPU STEST	OSC FLT DISABLE	INT1 NMI	PRIVILEGE DISABLE
	RP-0	RP-0	RP-1	RP-0	RP-1	RP-0	RP-0	RS-0

R = Read, P = Write only in Privilege state, S=Set only, -n = Value after reset

- Bit 0 - **PRIVILEGE DISABLE.** Privilege Mode Disable.  
Many bits controlling the system configuration can only be changed while in the privilege mode. After setting the system configuration bits, write a 1 to the Privilege Disable bit to disable the privilege mode and lock out any changes to the privilege protected bits. Only a Reset can clear the Privilege Disable bit.
- 0 = System is operating in privilege mode.  
1 = System is not operating in privilege mode.
- Bit 1 - **INT1 NMI.** Interrupt 1, Non-Maskable Interrupt.  
This bit determines whether Interrupt 1 is maskable or non-maskable (NMI). When Interrupt 1 is non-maskable, it is the second highest priority interrupt (Reset is highest) and is unaffected by the interrupt mask described in Section 5.1.2. The NMI mode disables the enable and priority select bits of the Interrupt 1 control register. The program can change this bit only in the privilege mode.
- 0 = Interrupt 1 is maskable.  
1 = Interrupt 1 is non-maskable (NMI).
- Bit 2 - **OSC FLT DISABLE.** Oscillator Fault Disable.  
This bit must be cleared (0) to ensure proper operation.
- Bit 3 - **CPU STEST.**  
This bit is used only during factory test and has no effect in normal operating modes.
- Bit 4 - **BUS STEST.**  
This bit must be cleared (0) to ensure proper operation.
- Bit 5 - **OSC FLT RST ENA.** Oscillator Fault Reset Enable.  
This bit determines whether or not a system reset is generated when an oscillator fault is detected. The oscillator fault circuitry will trigger below 20 kHz and may trigger anywhere between 20 kHz and 500 kHz. The only exit from this halt state is a Reset. Changes to this bit can occur only in the privilege mode.
- 0 = A Reset will not be generated if an oscillator fault is detected. An external hardware reset is required to restart the program.  
1 = A Reset is generated whenever an oscillator fault is detected if SCCR2.2 is cleared.

Bit 6 -

**PWRDWN/IDLE.** Powerdown/Idle.

This bit determines the mode entered by the CPU when an IDLE instruction is executed. Changes to this bit can occur only in the privilege mode.

- 0 = The processor will enter an idle mode when the program executes an IDLE instruction. The processor waits at the IDLE instruction until any enabled interrupt occurs. The processor then enters the interrupt routine and returns to the instruction after the Idle instruction..The idle is not a low-power mode.
- 1 = The processor will enter a low power mode when the program executes an IDLE instruction. The HALT/STANDBY bit determines the type of low power mode.

Bit 7 -

**HALT/STANDBY.**

The following descriptions apply only if the Powerdown/Idle bit is set, otherwise the Halt/Standby bit has no effect. See Section 4.1.4 for a description of the Halt and Standby modes. Changes to this bit can occur only in the privilege mode.

- 0 = When an IDLE instruction is executed, the processor will enter the Standby mode which stops program execution and disables the system clock to all nonessential peripherals. The system clock to the Timer 1 continues to run and the timer can generate an interrupt to bring the processor out of the Standby mode.
- 1 = When an IDLE instruction is executed, the processor will enter the Halt mode which stops the internal oscillator and suspends the system and peripheral operations. This mode provides the lowest power consumption.

4

## 4.2 Digital I/O Configuration

On TMS370 devices, the power, reset, MC, and crystal pins are dedicated to one function. Every other pin may be programmed to be a general purpose input and/or output, or a special function pin. Some of these pins are associated with the functions of the peripheral modules.

On TMS370Cx1x devices, 13 of a possible 22 I/O pins are dedicated to Ports A and D. Port A contains 8 pins and Port D contains 5 pins.

On TMS370Cx3x devices, 12 of a possible 36 I/O pins are dedicated to Ports A and D. Port A contains 8 pins Port D contains 4 pins.

On TMS370Cx5x devices, 32 of a possible 55 I/O pins are dedicated to Ports A, B, C and D; each port has 8 pins each.

Frame 2 of the peripheral file (memory addresses 1020h –102Fh) contain the control registers for reading, writing and configuring Ports A, B, C, and D. These registers are shown in Figure 4–4.

Figure 4–4. Digital Port Control Registers

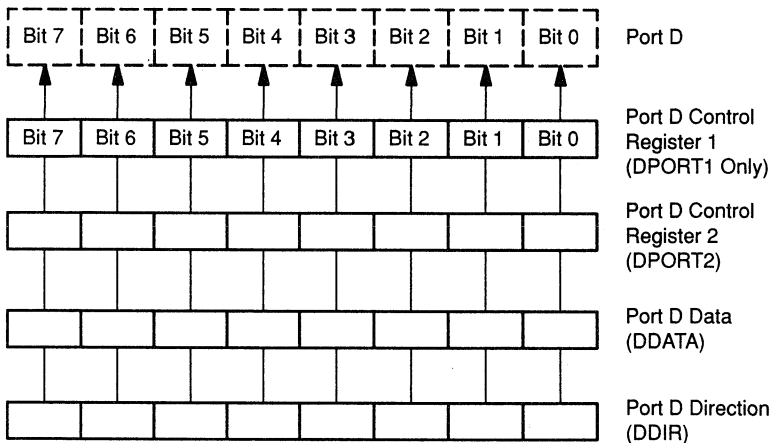
PERIPHERAL FILE FRAME 2: DIGITAL PORT CONTROL REGISTERS										
ADDR	PF	BIT 7	BIT 6	BIT 5	BIT 4	BIT 3	BIT 2	BIT 1	BIT 0	
1020h	20	RESERVED								APOINT1
1021h	21	PORT A CONTROL REGISTER 2								APOINT2
1022h	22	PORT A DATA								ADATA
1023h	23	PORT A DIRECTION								ADIR
1024h	24	RESERVED								BPOINT1
1025h	25	PORT B CONTROL REGISTER 2								BPOINT2
1026h	26	PORT B DATA								BDATA
1027h	27	PORT B DIRECTION								BDIR
1028h	28	RESERVED								CPOINT1
1029h	29	PORT C CONTROL REGISTER 2								CPOINT2
102Ah	2A	PORT C DATA								CDATA
102Bh	2B	PORT C DIRECTION								CDIR
102Ch	2C	PORT D CONTROL REGISTER 1								DPOINT1
102Dh	2D	PORT D CONTROL REGISTER 2								DPOINT2
102Eh	2E	PORT D DATA								DDATA
102Fh	2F	PORT D DIRECTION								DDIR

Each port has up to four control registers associated with it. They are:

- Port X Control Register 1 (XPORT1)
- Port X Control Register 2 (XPORT2)
- Port X Data (XDATA)
- Port X Direction (XDIR)

The same bit position of each of these registers affects the corresponding bit in the port. For example, Bit 0 of registers DPORT1, DPORT2, DDATA and DDIR control Port D, bit 0. This is illustrated in Figure 4–5.

**Figure 4–5. Port Control Register Operation**



Bits from the XPORT1 and XPORT2 registers determine the function of the corresponding port pin, either a I/O, data, address, or control signal depending on the port. The same bit from the XDIR register determines the direction (input or output) if the pin has been defined as a I/O pin. The same bit from the XDATA register is the bit to write to or read from if the pin has been defined as a I/O pin.

Figure 4–6 shows the function that each pin can serve depending on which port contains the pin. Definitions of the memory expansion signals of Function A and Function B follow the figure.



**Figure 4–6. Port Configuration Registers Set-Up**

Port Pin	Output		Function A	Function B	µP Mode
			(µC Mode)	(µC Mode)	
	XPORT1 = 0* XPORT2 = 0 XDATA = y XDIR = 0	XPORT1 = 0* XPORT2 = 0 XDATA = q XDIR = 1	XPORT1 = 0* XPORT2 = 1 XDATA = x XDIR = x	XPORT1 = 1* XPORT2 = 1 XDATA = x XDIR = x	
A 0–7	Data IN y	Data OUT q	DATA BUS	RESERVED	DATA BUS
B 0–7	Data IN y	Data OUT q	LOW ADDR	RESERVED	LOW ADDR
C 0–7	Data IN y	Data OUT q	HI ADDR	RESERVED	HI ADDR
D 0	Data IN y	Data OUT q	$\overline{\text{CSE2}}$	$\overline{\text{OCF}}$	$\overline{\text{OCF}}$
D 1	Data IN y	Data OUT q	$\overline{\text{CSH3}}$		**
D 2	Data IN y	Data OUT q	$\overline{\text{CSH2}}$		**
D 3	Data IN y	Data OUT q	CLKOUT	CLKOUT	CLKOUT
D 4	Data IN y	Data OUT q	R/W	R/W	R/W
D 5	Data IN y	Data OUT q	$\overline{\text{CSPF}}$		**
D 6	Data IN y	Data OUT q	$\overline{\text{CSH1}}$	$\overline{\text{EDS}}$	$\overline{\text{EDS}}$
D 7	Data IN y	Data OUT q	$\overline{\text{CSE1}}$	WAIT	WAIT

XPORT1 = 1, XPORT2 = 0; not defined.

\* XPORT1 exists for DPORT only.

\*\* Reserved. Not available.

LOW ADDR/HI ADDR – External memory address bus. Output only.

DATA BUS – External data bus. Input and output.

$\overline{\text{EDS}}$  - External Data strobe: This signal goes low during external memory operations. The rising edge of  $\overline{\text{EDS}}$  validates the read input data and the write data is available after the falling edge of  $\overline{\text{EDS}}$ .

$\overline{\text{CSH1}}$  - Chip Select Half 1: This signal has the same timing as  $\overline{\text{EDS}}$  but it only goes active during access to the upper half of memory (locations 8000h – FFFFh). Used to select banks of memory. Setting this pin to a high-level general-purpose output disables the bank.

$\overline{\text{CSH2}}$  - Chip Select Half 2: This signal has the same timing as  $\overline{\text{EDS}}$  but it only goes active during access to the upper half of memory (locations 8000h – FFFFh). Used to select a second bank of memory. Setting this pin to a high-level general-purpose output disables the bank.

$\overline{\text{CSH3}}$  - Chip Select Half 3: This signal has the same timing as  $\overline{\text{EDS}}$  but it only goes active during access to the upper half of memory (loca-

tions 8000h – FFFFh). Used to select a third bank of memory. Setting this pin to a high-level general-purpose output disables the bank.

$\overline{CSE1}$  - Chip Select Eighth 1: This signal has the same timing as  $\overline{EDS}$  but it only goes active during accesses to an eighth of memory (locations 2000h – 3FFFh). Used to select banks of memory. Setting this pin to a high-level general-purpose output disables the bank.

$\overline{CSE2}$  - Chip Select Eighth 2: This signal has the same timing as  $\overline{EDS}$  but it only goes active during accesses to an eighth of memory (locations 2000h – 3FFFh). Used to select a second bank of memory. Setting this pin to a high-level general-purpose output disables the bank.

$\overline{CSPF}$  - Chip Select Peripheral File: This signal has the same timing as  $\overline{EDS}$  but it only goes active during access to external frames of the peripheral file (locations 10C0h – 10FFh).

CLKOUT - Clock Output: Outputs one quarter of the crystal or external oscillator frequency. Used to synchronize external peripherals.

R/ $\overline{W}$  - Read or Write operation: Goes high at the beginning of read operations and low during write operations. This line is active during both internal and external accesses.

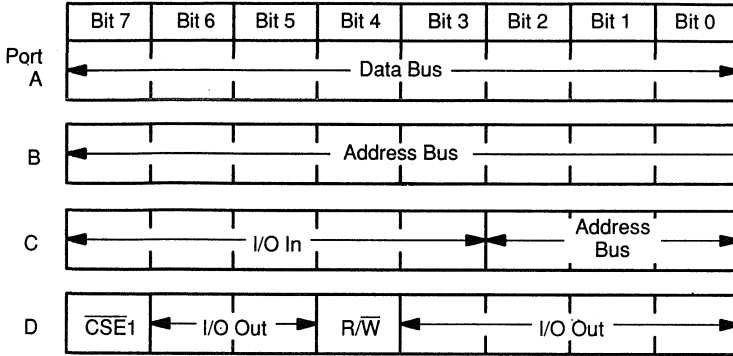
WAIT - WAIT input: An external, low signal applied to this pin, when sampled, causes the processor to hold the information on the expansion bus for 1 or more extra clock out cycles. This pin is sampled during the rising edge of CLKOUT after  $\overline{EDS}$  goes active.

$\overline{OCF}$  - Opcode Fetch: Goes low at the beginning of a memory read operation that fetches the first byte of an instruction. It then resumes its high level at the end of the Opcode fetch(s).

The pre-decoded chip selects allow the TMS370 to access external addresses with a minimum of external logic. In many cases no external logic is necessary between the TMS370 and the peripheral device because of the pre-decoded chip selects, autowait features, and the non-multiplexed bus. Another advantage of the chip selects is the ability to do easy memory bank selection. Without bank selection, the  $\overline{CSH1}$ ,  $\overline{CSE1}$ , and  $\overline{CSPF}$  signals can easily access about 40 kilobytes of memory in the three different areas. With bank selection, the processor can access 112 kilobytes of memory.

**Example 4–1. Digital Ports Set-up Example**

To illustrate configuring the Digital Ports, assume that a TMS370C050 is to operate in the expanded microcomputer mode, and that 2 kilobytes of memory is needed at 2000h to 27FFh. The top half of the figure below shows the port configuration wanted. Port A is set as the external data bus. Port B is the low-order byte of the address bus. Bits 0 through 2 of Port C are the high-order address bits of the eleven bits necessary to access 2 kilobytes of memory. Bits 4 through 7 of Port C are set as I/O input. In Port D, bit 7 is the chip select signal to access 2000h to 3FFFh; and bit 4 is used for external memory control signal  $\overline{R/W}$ . The remaining bits of Port D are used as I/O output.



4

Port A Control Registers

1021h	1	1	1	1	1	1	1	1	MOV #0FFH, P021
1022h	x	x	x	x	x	x	x	x	
1023h	x	x	x	x	x	x	x	x	

Port B Control Registers

1025h	1	1	1	1	1	1	1	1	MOV #0FFH, P025
1026h	x	x	x	x	x	x	x	x	
1027h	x	x	x	x	x	x	x	x	

Port C Control Registers

1029h	0	0	0	0	0	1	1	1	MOV #007H, P029
102Ah	x	x	x	x	x	x	x	x	
102Bh	0	0	0	0	0	X	X	X	MOV #0, P02B

Port D Control Registers

102Ch	0	0	0	0	0	0	0	0	MOV #0, P02C
102Dh	1	0	0	1	0	0	0	0	MOV #090h, P02D
102Eh	x	q	q	x	q	q	q	q	
102Fh	x	1	1	x	1	1	1	1	MOV #0FFH, P02F

The bottom half of the above figure shows the port control registers set up to establish the configuration shown in the top half of the figure. To determine the bits needed to set the registers, use Figure 4–6. For example, to set Port A as the data bus, find Port A in the left hand column of Figure 4–6. Look across the row to find Data bus, then follow the column up to find

1  
x  
x

in the column heading. These are the bits needed to set *each* Port A bit as a data bus.

The assembly language instructions on the right of the preceding figure show one method of setting up the registers to the left. The Pxxx operand indicates peripheral file access (See Chapter 13 for more information on peripheral file instructions).

When operating with internal program memory disabled, any access to the Port peripheral frame, 1020h – 102Fh, is decoded as external address. Memory accesses to this frame can control external hardware which emulates the digital I/O functions.

#### 4.2.1 Microprocessor Mode

Initializing a device with Bus Expansion to the microprocessor mode forces Ports A,B,C and D to Function B as shown in Figure 4–6. Port A is the data bus, Port B is the low-order-address bus and Port C is the high-order-address bus in this mode. Neither the TMS370Cx1x nor the TMS370Cx3x devices is defined for operation in the memory expansion modes so the device must be powered up in the microcomputer mode.

#### 4.2.2 Microcomputer Mode

Initializing the device to the microcomputer mode forces Ports A,B,C and D to General Purpose high impedance inputs. The program can set the control bits to change the function of the port pins to one of four functions: General Purpose Output, General Purpose Input, Function A, or Function B.

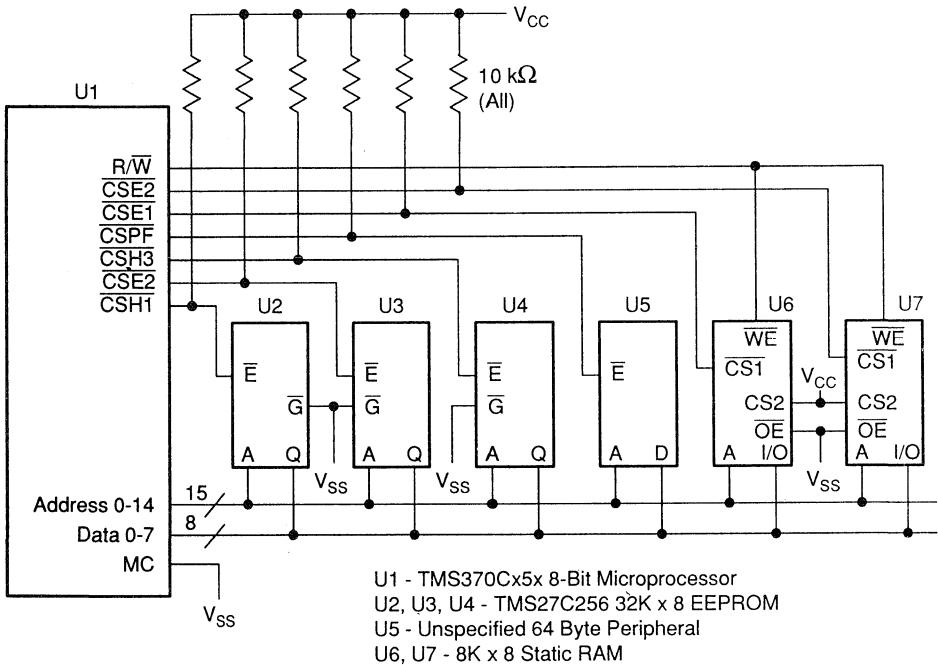
When changing a pin from an general-purpose input pin to an output pin, write to the Data register first to set up the data and then set the data direction register. This prevents unknown data on the pin from interfering with the external circuitry.

The TMS370 in the microcomputer mode can individually reconfigure any address, data, or control signal to use only the necessary signals and leave the other signals on the port for general purpose I/O operations.

Figure 4-7 shows an example of the TMS370Cx5x interfaced to 112 kilobytes of external memory (see Chapter 14 for a more complete example). The Function-A chip-select signals are used to enable one of three banks of EPROM, an external peripheral device, and one of two banks of static RAM. In this example, all eight bits of port A are used as the data bus, all eight bits of port B are used as the address LSB, and seven port C bits are used to complete the 15 bit address bus.

Figure 4-7. System Interface Example

4



Introduction	1
Assembly Language Instruction Set	13
TMS370 Family Devices	2
Design Aids	14
CPU and Memory Organization	3
Development Support	15
System and Digital I/O Configuration	4
Electrical Specifications	16
Interrupts and System Reset	5
Customer Information	17
EEPROM Modules	6
Appendices	A-H
Timer 1 Module	7
Timer 2 Module	8
Serial Communications Interface (SCI) Port	9
Serial Peripheral Interface (SPI) Module	10
Analog-to-Digital Converter Module	11
TMS370 Programmable Acquisition and Control Timer	12





# Interrupts and System Reset

---

---

---

This chapter discusses the internal and external interrupts of the TMS370. The methods of device reset are also considered. This chapter covers the following topics:

<b>Section</b>	<b>Page</b>
5.1 Interrupts .....	5-2
5.2 Resets .....	5-14

## 5.1 Interrupts

The TMS370 programmable interrupt structure allows flexible on-chip and external interrupt configurations to meet real-time interrupt-driven application requirements.

Whenever an internal or external circuit requests an enabled interrupt, the processor finishes the current instruction and then fetches, from the Interrupt Table, the address of the appropriate interrupt service routine. The processor then pushes the contents of the program counter and status register onto the stack and begins execution at the interrupt service routine address found in the Interrupt Table. When the interrupt service routine completes, the program executes a RTI (Return from Interrupt) instruction which pops the previous status-register and program-counter contents from the stack. The processor resumes execution from the point of interruption.

### 5

#### 5.1.1 Interrupt Operation

The hardware interrupt structure includes two selectable priority levels as shown in Figure 5–1. Interrupt level 1 has a higher priority than interrupt level 2. The two priority levels can be independently masked by clearing the global interrupt enable bits (IE1 and IE2) of the status register (described in Section 3.2.2).

During system initialization, the application program can assign system interrupts to either the high or low priority level. The program can reassign priority levels at any time except for those priority levels which are protected by the Privilege Mode. Within each level, hardware determines the interrupt priority.

The processor services the pending interrupts upon completion of current instruction execution, depending on their interrupt mask and priority conditions. The processor services all enabled Level 1 interrupts before servicing any Level 2 interrupts. Within each level, the processor services the highest priority interrupts first. The hardware priorities of the devices available at time of printing are shown in Table 5–1.

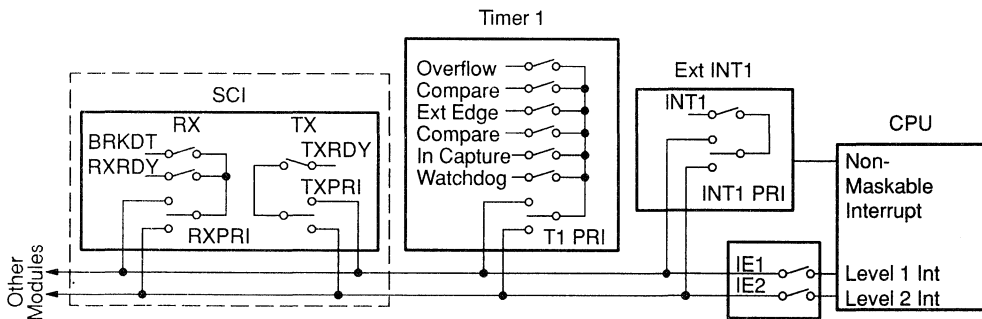
**Table 5–1. Module Interrupt Priority**

Vector Start Address	Module		Device Module Priority			Module Vector Bytes
			TMS370Cx1x	TMS370Cx3x	TMS370Cx5x	
7F9Ch	PACT	Group 2	NA	6 (See Note.)	NA	36
		Group 3	NA	7 (See Note.)	NA	
		Group 1	NA	5 (See Note.)	NA	
7FECCh	A/D Converter		NA	8	10	2
7FEEh	Timer 2		NA	NA	9	2
7FF0h	SCI	Transmit	NA	NA	8	4
		Receive	NA	NA	7	
7FF4h	Timer 1		6	NA	6	2
7FF6h	SPI		5	NA	5	2
7FF8h	External INT3		4	4	4	6
7FFAh	External INT2		3	3	3	
7FFCh	External INT1		2	2	2	
7FFEh	RESET		1	1	1	2

**5**

**Note:** The In-Circuit Emulator with PACT has the PACT module as the lowest priority interrupts, while the device family (TMS370Cx3x) has the A/D interrupt at lowest priority.

**Figure 5–1. Interrupt Control**



The TMS370 architecture allows there to be up to 128 independent interrupt vectors. These system interrupt vectors must be located within the memory locations 7F00h to 7FFFh. This memory space also contains the Trap tables, and 12 bytes reserved for Texas Instruments' use. If the device does not define this memory for an interrupt vector, it may be used for program memory. Table 5-2 shows the interrupt vector source(s) and its corresponding address. Note that a system interrupt may have multiple interrupt sources.

**Table 5–2. Interrupt Vector Sources**

Module	Vector Address	Interrupt Source	Interrupt Flag	System Interrupt	Priority in Group†
PACT (Group 2)	7F9Ch, 7F9Dh	PACT SCI TXINT	PACT TXRDY	PTXINT	2
	7F9Eh, 7F9Fh	PACT SCI RXINT	PACT RXRDY	PRXINT	1
PACT (Group 3)	7FA0h, 7FA1h	PACT Cmd/Def Entry 0	CMD/DEF INT 0 FLAG	CDINT0	1
	7FA2h, 7FA3h	PACT Cmd/Def Entry 1	CMD/DEF INT 1 FLAG	CDINT1	2
	7FA4h, 7FA5h	PACT Cmd/Def Entry 2	CMD/DEF INT 2 FLAG	CDINT2	3
	7FA6h, 7FA7h	PACT Cmd/Def Entry 3	CMD/DEF INT 3 FLAG	CDINT3	4
	7FA8h, 7FA9h	PACT Cmd/Def Entry 4	CMD/DEF INT 4 FLAG	CDINT4	5
	7FAAh, 7FABh	PACT Cmd/Def Entry 5	CMD/DEF INT 5 FLAG	CDINT5	6
	7FACh, 7FADh	PACT Cmd/Def Entry 6	CMD/DEF INT 6 FLAG	CDINT6	7
	7FAEh, 7FAFh	PACT Cmd/Def Entry 7	CMD/DEF INT 7 FLAG	CDINT7	8
PACT (Group 1)	7FB0h, 7FB1h	PACT Circular Buffer (Half/Full)	BUFFER HALF/FULL INT FLAG	BUFINT	1
	7FB2h, 7FB3h	PACT CP6 Edge	CP6 INT FLAG	CP6INT	2
	7FB4h, 7FB5h	PACT CP5 Edge	CP5 INT FLAG	CP5INT	3
	7FB6h, 7FB7h	PACT CP4 Edge	CP4 INT FLAG	CP4INT	4
	7FB8h, 7FB9h	PACT CP3 Edge	CP3 INT FLAG	CP3INT	5
	7FBAh, 7FBBh	PACT CP2 Edge	CP2 INT FLAG	CP2INT	6
	7FBCh, 7FBDh	PACT CP1 Edge	CP1 INT FLAG	CP1INT	7
	7FBEh, 7FBFh	PACT Default Timer Overflow	DEFTIM OVRFL INT FLAG	POVRFL INT	8

† 1 is the highest priority.

**Table 5–2. Interrupt Vector Sources (Concluded)**

Module	Vector or Address	Interrupt Source	Interrupt Flag	System Interrupt	Priority in Group†
A/D	7FEEh, 7FEDh	A/D Conversion Complete	AD INT FLAG	ADINT	1
Timer 2	7FEEh, 7FEFh	Timer 2 Overflow	T2 OVRFL INT FLAG	T2INT	1
		Timer 2 Compare 1	T2C1 INT FLAG		
		Timer 2 Compare 2	T2C2 INT FLAG		
		Timer 2 External Edge	T2EDGE INT FLAG		
Timer 2	7FEEh, 7FEFh	Timer 2 Input Capture 1	T2IC1 INT FLAG	T2INT	1
		Timer 2 Input Capture 2	T2IC2 INT FLAG		
SCI TX	7FF0h, 7FF1h	SCI TX Data Register Empty	TXRDY FLAG	TXINT	1
SCI RX	7FF2h, 7FF3h	SCI RX Data Register Full	RXRDY FLAG	RXINT	1
		SCI RX Break Detect	BRKDT FLAG		
Timer 1	7FF4h, 7FF5h	Timer 1 Overflow	T1 OVRFL INT FLAG	T1INT	1
		Timer 1 Compare 1	T1C1 INT FLAG		
		Timer 1 Compare 2	T1C2 INT FLAG		
		Timer 1 External Edge	T1EDGE INT FLAG		
		Timer 1 Input Capture 1	T1IC1 INT FLAG		
		Watchdog Overflow	WD OVRFL INT FLAG		
SPI	7FF6h, 7FF7h	SPI RX/TX Complete	SPI INT FLAG	SPIINT	1
External INT	7FF8h, 7FF9h	External INT3	INT3 FLAG	INT3	1
	7FFAh, 7FFBh	External INT2	INT2 FLAG	INT2	1
	7FFCh, 7FFDh	External INT1	INT1 FLAG	INT1	1
RESET	7FFEh, 7FFFh	External RESET	COLD START	RESET	1
		Watchdog Overflow	WD OVRFL INT FLAG		
		Oscillator Fault Detect	WD OVRFL INT FLAG		

5

The application program can individually enable or disable all of the interrupt sources using local interrupt enable control bits in the associated peripheral file. Also, software can read each interrupt source's flag bit in order to determine which interrupt source generated the system interrupt.

The processor acknowledges an interrupt if its flag bit equals 1 and the interrupt is enabled. The interrupt service routine must clear all appropriate flag bits before leaving the routine to avoid immediately re-entering the same interrupt service routine.

Interrupts are sampled and arbitrated by the CPU during every opcode fetch. If one or more requests are pending (and the appropriate enable bits are set in the status register for maskable interrupts), then at the normal completion of the opcode fetch, the interrupt context switch begins. The new opcode is discarded and the program counter is rewound to point to the discarded instruction. Thus, at the completion of the interrupt service routine, the discarded instruction is fetched again. The context switch routine proceeds as follows.

5

- 1) Increment the stack pointer (SP) and store the contents of the status register (ST) at the location pointed to by the SP.
- 2) Set the ST to 00h (disables further interrupt recognition).
- 3) Obtain the identity of the interrupting peripheral.
- 4) Rewind the program counter to point to the aborted opcode.
- 5) Increment SP and store the original PC high byte at the location pointed to by the SP.
- 6) Get the interrupt-service-routine address (low byte) and store it in the PC low byte (PCL).
- 7) Increment SP and store the original PC (low byte) at the location pointed to by SP.
- 8) Get address (high byte) of interrupt service routine and store it in the PC high byte (PCH).
- 9) Resume instruction execution with the new PC contents.

It takes a minimum of 15 cycles from the time that an interrupt is triggered, to the reading of the first instruction of the interrupt service routine. The time depends on the instruction in progress when the interrupt is asserted and at what point during an instruction the interrupt is asserted. The worst case occurs if the interrupt occurs near the start of a Divide instruction; the processor may require up to 78 clock cycles to enter the interrupt service routine. If wait states are needed, the appropriate number of cycles must be added. Also, an external interrupt (INT1, INT2, or INT3) requires 2 extra clock cycles to synchronize before the processor can detect it.

## 5.1.2 External Interrupts

External pins INT1, INT2 and INT3 allow external devices to interrupt the program and enter a specific interrupt service routine. The INT1, INT2, and INT3 control registers in peripheral file frame 1 govern the software configuration of the external interrupts. Figure 5–2 shows these registers.

**Figure 5–2. Peripheral File Frame 1 – External Interrupt Control Registers**

		Peripheral File Frame 1: External Interrupt Control Registers								
Address	PF	Bit 7	Bit 6	Bit 5	Bit 4	Bit 3	Bit 2	Bit 1	Bit 0	
1017h	P017	INT1 FLAG	INT1 PIN DATA	—	—	—	INT1 POLARITY	INT1 PRIORITY	INT1 ENABLE	INT1
1018h	P018	INT2 FLAG	INT2 PIN DATA	—	INT2 DATA DIR	INT2 DATA OUT	INT2 POLARITY	INT2 PRIORITY	INT2 ENABLE	INT2
1019h	P019	INT3 FLAG	INT3 PIN DATA	—	INT3 DATA DIR	INT3 DATA OUT	INT3 POLARITY	INT3 PRIORITY	INT3 ENABLE	INT3

5

Software can configure each external interrupt individually, through the interrupt polarity bits, to trigger on either a rising edge or a falling edge. If the interrupt function is not required, the software can configure external interrupts INT2 and INT3 to be general purpose input/output pins, and INT1 to be an input pin.

INT1 can be programmed to be a maskable or non-maskable interrupt. When INT1 is non-maskable, it cannot be masked by the individual or global mask bits. Remember that the INT1 NMI bit (SCCR2.1) is protected during nonprivileged operation and should be configured during the initialization sequence following reset (see INT1 NMI bit description in Section 4.1.5.3).

The non-maskable interrupt is used for events that you want to respond to immediately. For example this event could be derived from monitoring the power supply and saving important data to EEPROM whenever a brown-out/power loss condition occurs.

**Note:**

When using a NMI, the interrupt is taken on EVERY active edge of the INT1 pin. This pin should be debounced to avoid multiple interrupts which could cause the stack to overflow. Once the stack has overflowed the program may not operate as expected.

The application program must configure the following bits for each interrupt to function correctly. The INT PRIORITY bit configures the interrupt as either a level 1 or a level 2 interrupt. The INT POLARITY bit selects the trigger as either a falling edge or a rising edge. The INT ENABLE bit allows the request to be transmitted to the CPU if either the IE1 or IE2 enable bit, whichever is appropriate, is enabled.

The INT FLAG indicates that the selected edge (rising or falling) has occurred. If the enables are set, an interrupt is requested. This bit remains a 1 until the software or a RESET clears it. The INT FLAG bit is useful for programs which poll the interrupt flag instead of generating a system interrupt.

The INT PIN DATA bit shows the level presently on the interrupt pin. This also allows the use of this bit as a simple input pin if the interrupt function is not needed.

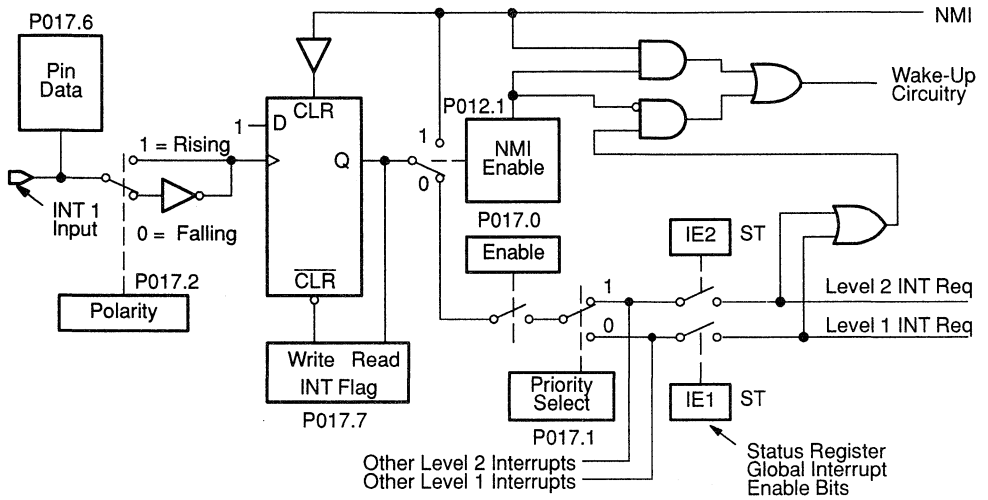
5

On interrupts 2 and 3, the INT DATA DIR determines if the pin functions as a general purpose output or as an input/interrupt pin. If you select the general purpose output function, then the value written by software to the INT DATA OUT bit determines the level of the output.

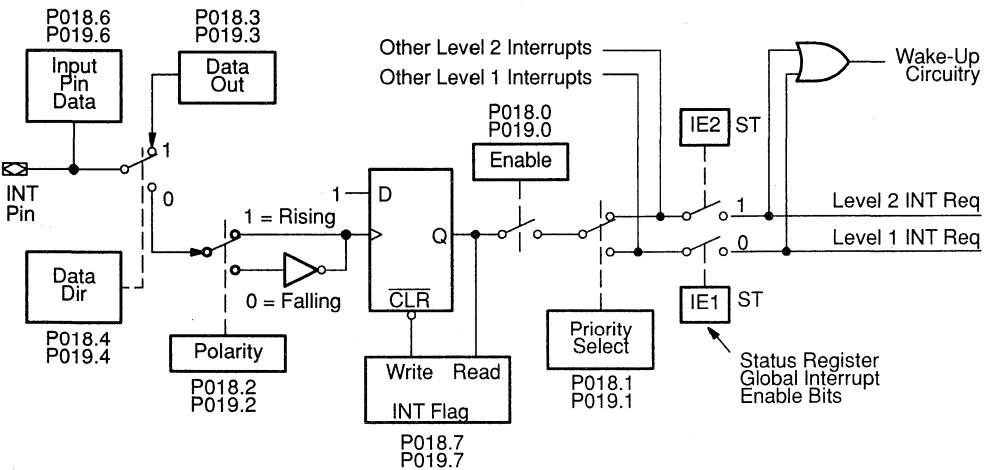
All external interrupts can bring the processor out of both the halt and the standby low-power modes if the interrupt enable and the interrupt level mask are enabled. Please note that in Halt mode the interrupt is detected on the level and not the edge. For further information refer to Section 4.1.4.3.



**Figure 5-3. Interrupt 1 Block Diagram**



**Figure 5-4. Interrupts 2 and 3 Block Diagram**



### 5.1.3 Interrupt Control Registers

**Interrupt 1 Control Register (INT1)**  
**[Memory Address – 1017h]**

BIT#-	7	6	5	4	3	2	1	0
P017	INT1 FLAG	INT1 PIN DATA	—	—	—	INT1 POLARITY	INT1 PRIORITY	INT1 ENABLE
	RC-0	R-0				RW-0	RW-0	RW-0

R=Read, P=Write, C=Clear only, -n=Value after reset

- Bit 0 - **INT1 ENABLE.** Interrupt 1 Enable.  
 This bit enables the interrupts for the INT1 pin. This bit is ignored if INT1 NMI=1.  
 1 = Enable INT1 interrupts.  
 0 = Disables INT1 interrupts.
- Bit 1 - **INT1 PRIORITY.** Interrupt 1 priority.  
 This bit determines interrupt level of the INT1 pin; either a high, level-1 interrupt or a low, level-2 interrupt. This bit is ignored if INT1 NMI=1.  
 1 = Level 2 interrupt (low level).  
 0 = Level 1 interrupt (high level).
- Bit 2 - **INT1 POLARITY.** Interrupt 1 Polarity.  
 This bit determines whether INT1 triggers on a rising edge or a falling edge.  
 1 = Triggers on a rising edge (low-to-high transition)  
 0 = Triggers on a falling edge (high-to-low transition)
- Bits 3,4,5- Reserved. Read data is indeterminate.
- Bit 6 - **INT1 PIN DATA.** Interrupt 1 Pin Data.  
 This bit displays the current condition of the INT1 pin.  
 1 = High level input voltage ( $V_{IH}$ ) at the INT1 pin.  
 0 = Low level input voltage ( $V_{IL}$ ) at the INT1 pin.
- Bit 7 - **INT1 FLAG.** Interrupt 1 Flag.  
 This bit indicates that the selected transition on INT1 has occurred. An interrupt can occur as long as this bit remains set, thus the application program must clear this bit during the interrupt handling routine. This bit will be set even if the Interrupt1 Enable bit is cleared.  
 1 = transition detected  
 0 = no transition

5

**Interrupt 2 Control Register (INT2)**  
**[Memory Address – 1018h]**

BIT#-	7	6	5	4	3	2	1	0
P018	INT2 FLAG	INT2 PIN DATA	—	INT2 DATA DIR	INT2 DATA OUT	INT2 POLARITY	INT2 PRIORITY	INT2 ENABLE
	RC-0	R-0		RW-0	RW-0	RW-0	RW-0	RW-0

R=Read, P=Write, C=Clear only, -n=Value after reset

- Bit 0 - **INT2 ENABLE.** Interrupt 2 Enable.  
 This bit enables the interrupts for the INT2 pin.  
 1 = Enable INT2 interrupts.  
 0 = Disables INT2 interrupts.
- Bit 1 - **INT2 PRIORITY.** Interrupt 2 Priority.  
 This bit determines the interrupt level of the INT2 pin; either a high, level-1 interrupt or a low, level-2 interrupt.  
 1 = Level 2 interrupt (low level).  
 0 = Level 1 interrupt (high level).
- Bit 2 - **INT2 POLARITY.** Interrupt 2 Polarity.  
 This bit determines whether INT2 triggers on a rising edge or a falling edge.  
 1 = Triggers on a rising edge (low-to-high transition).  
 0 = Triggers on a falling edge (high-to-low transition).
- Bit 3 - **INT2 DATA OUT.** Interrupt 2 Data Out.  
 If software configures the INT2 pin as an output pin (INT2 DATA DIR=1), then the value that the software writes to the INT2 DATA OUT bit determines the value of that output pin.
- Bit 4 - **INT2 DATA DIR.** Interrupt 2 Data Direction. The INT2 pin can be configured as either an output pin or as an input/interrupt pin.  
 1 = INT2 pin is an output pin.  
 0 = INT2 pin is an input/interrupt pin.
- Bit 5 - Reserved. Read data is indeterminate.
- Bit 6 - **INT2 PIN DATA.** Interrupt 2 Pin Data.  
 This bit displays the current value of the INT2 pin.  
 1 = High-level input voltage ( $V_{IH}$ ) at the INT2 pin.  
 0 = Low-level input voltage ( $V_{IL}$ ) at the INT2 pin.
- Bit 7 - **INT2 FLAG.** Interrupt 2 Flag.  
 This bit indicates that the selected transition on INT2 has occurred. An interrupt can occur as long as this bit remains set, thus the program must clear this bit during the interrupt handling routine. This bit will be set even if the INT2 ENABLE bit is cleared.  
 1 = transition detected  
 0 = no transition

**Interrupt 3 Control Register (INT3)  
[Memory Address – 1019h]**

BIT#-	7	6	5	4	3	2	1	0
P019	INT3 FLAG	INT3 PIN DATA	—	INT3 DATA DIR	INT3 DATA OUT	INT3 POLARITY	INT3 PRIORITY	INT3 ENABLE
	RC-0	R-0		RW-0	RW-0	RW-0	RW-0	RW-0

R=Read, P=Write, C=Clear only, -n=Value after reset

- Bit 0 - **INT3 ENABLE.** Interrupt 3 Enable.  
This bit enables the interrupts for the INT3 pin.  
  
1 = Enable INT3 interrupts.  
0 = Disables INT3 interrupts.
- Bit 1 - **INT3 PRIORITY.** Interrupt 3 priority.  
This bit determines the interrupt level of the INT1 pin; either a high, level-1 interrupt or a low, level-2 interrupt.  
  
1 = Level-2 interrupt (low level).  
0 = Level-1 interrupt (high level).
- Bit 2 - **INT3 POLARITY.** Interrupt 3 Polarity.  
This bit determines whether INT3 triggers on a rising edge or a falling edge.  
  
1 = Triggers on a rising edge (low-to-high transition).  
0 = Triggers on a falling edge (high-to-low transition).
- Bit 3 - **INT3 DATA OUT.** Interrupt 3 Data Out.  
If software configures the INT3 pin as an output pin (INT3 DATA DIR=1), then the value that the software writes to the INT3 DATA OUT bit determines the value of that output pin.
- Bit 4 - **INT3 DATA DIR.** Interrupt 3 Data Direction.  
The INT3 pin can be configured as either an output pin or as an input/interrupt pin.  
  
1 = INT3 pin is an output pin.  
0 = INT3 pin is an input/interrupt pin.
- Bit 5 - Reserved. Read data is indeterminate.
- Bit 6 - **INT3 PIN DATA.** Interrupt 3 Pin Data.  
This bit displays the current condition of the INT3 pin.  
  
1 = High-level input voltage ( $V_{IH}$ ) at the INT3 pin.  
0 = Low-level input voltage ( $V_{IL}$ ) at the INT3 pin.
- Bit 7 - **INT3 FLAG.** Interrupt 3 Flag.  
This bit indicates that the selected transition on INT3 has occurred. An interrupt can occur as long as this bit remains set, thus the program must clear this bit during the interrupt handling routine. This bit will be set even if the Interrupt 3 Enable bit is cleared.  
  
1 = transition detected  
0 = no transition

5

### 5.1.4 Multiple Interrupt Servicing

When servicing an interrupt, the processor automatically clears the global interrupt enable bits IE1 and IE2. This prevents all other interrupts from being recognized during the execution of the interrupt service routine. Once the service routine is completed by executing the RTI (Return from Interrupt) instruction, the old status register contents are popped from the stack. This returns the IE1 and IE2 to their original conditions and allows any pending interrupts to be recognized.

An Interrupt service routine can allow nested interrupts by executing the EINT, EINTL or EINTH instructions to set the global Interrupt Enable bits in the status register. This permits other interrupts to be recognized during the service routine execution. When a nested interrupt service routine completes, it returns to the previous interrupt service routine when the RTI instruction executes. Too many nested interrupts could overflow the stack causing program failure.

## 5.2 Resets

The TMS370 has three possible reset sources: a low input to the  $\overline{\text{RESET}}$  pin, a programmable watchdog timer timeout (described in Section 7.3 or Section 12.7), or a programmable oscillator fault failure (described in Section 4.1.2). After the occurrence of a reset, the program can interrogate the status bits (shown in Table 5–3) to determine the source of the reset in order to take appropriate action. If none of the sources, indicated in Table 5–3, caused the reset then the  $\overline{\text{RESET}}$  pin was pulled low by external hardware or the PACT module watchdog.

**Table 5–3. Reset Sources**

Register	Address	PF	Bit #	Control Bit	Source of Reset
SCCR0	1010h	P010	7	COLD START	Cold or Warm start reset.
SCCR0	1010h	P010	4	OSC FLT FLAG	Oscillator out of range.
T1CTL2	104Ah	P04A	5	WD OVRFL INT FLAG	Watchdog timer timeout.

The  $\overline{\text{RESET}}$  pin starts the hardware initialization and ensures an orderly software startup. The  $\overline{\text{RESET}}$  pin is an input/output pin. A low level pulse initiates the reset sequence. The processor may detect short reset pulses of a few nanoseconds but a low level (active) of one cycle is necessary to guarantee that the device sees the reset signal. The microcontroller is held in reset until the  $\overline{\text{RESET}}$  pin goes inactive (high). If the reset input signal remains low for less than eight system clock cycles, the processor holds the external  $\overline{\text{RESET}}$  pin low for eight system clock cycles to reset external system components.

Recall that the basic operating mode, microcomputer or microprocessor, is determined by the voltage level applied to the MC pin when the  $\overline{\text{RESET}}$  pin goes inactive (high). The  $\overline{\text{RESET}}$  pin can be pulled low at any time during operation to start the reset sequence immediately.

The sequence of events during reset is as follows:

- 1) Initialize CPU registers: ST = 00h, SP = 01h.
- 2) Initialize registers A and B to 00h (no other RAM is changed).
- 3) Read the contents of 7FFFh and store in the PC low byte (PCL).
- 4) Read the contents of 7FFEh and store in the PC high byte (PCH).
- 5) Start user program execution with an opcode fetch from the address pointed to by the PC.

The reset takes 21 cycles from the time reset is released to the first opcode fetch in the microcomputer mode and takes 23 cycles in the microprocessor mode.

When the Watchdog overflow or the Oscillator Fault detection circuit generates a reset, the  $\overline{\text{RESET}}$  pin is pulled low in order to reset other external components in the system.

During a reset, RAM contents (except for Register A and Register B) are unchanged and the majority of the peripheral file bits are set to 0 with the exception of the bits shown Table 5–4.

**Table 5–4. Control-Bit States Following Reset**

Register	Control Bit	Powerup	Warm Reset	
		Microcomputer	Microcomputer	Microprocessor
SCCRO	$\mu\text{P}/\mu\text{C}$ Mode	0	0	1
	MC PIN DATA	0	0	1
	COLD START	1	See Note 1.	See Note 1.
	OSC FLT FLAG	0	See Note 1.	See Note 1.
XPORT1 (See Note 2.)	all 8 bits	0	0	1
XPORT2 (See Note 2.)	all 8 bits	0	0	1
T1CTL2	WD OVRFL FLAG	0	See Note 1.	See Note 1.
TXCTL	TX EMPTY	1	1	1
	TXRDY	1	1	1
ADSTAT	AD READY	1	1	1
PACT	PACT TXRDY	1	1	1

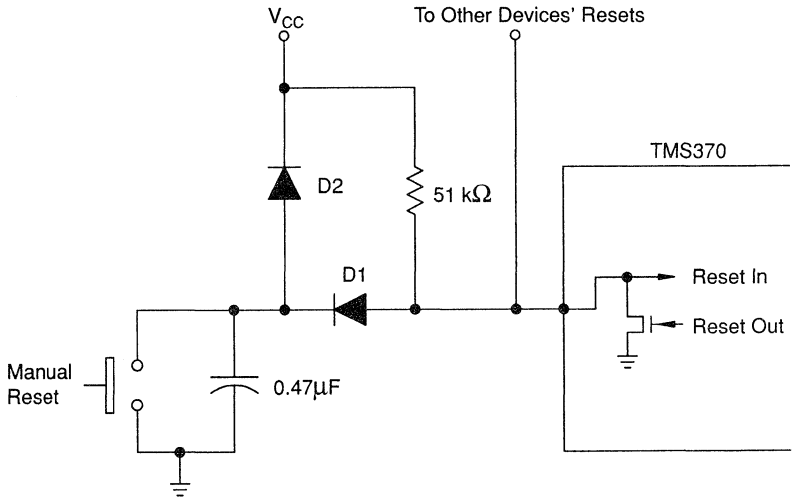
**Notes:** 1) State determined by cause of reset. See bit descriptions.

2) Refers to Port Control Registers A, B, C, and D.

### 5.2.1 Simple Reset Circuitry

An application must activate the  $\overline{\text{RESET}}$  pin at power-up with an external input or a RC power-up circuit. Reset must be held low until the clock signal is valid. Figure 5–5 shows a simple reset circuit that will hold reset low during power-up.

Figure 5–5. Typical Reset Circuit



5

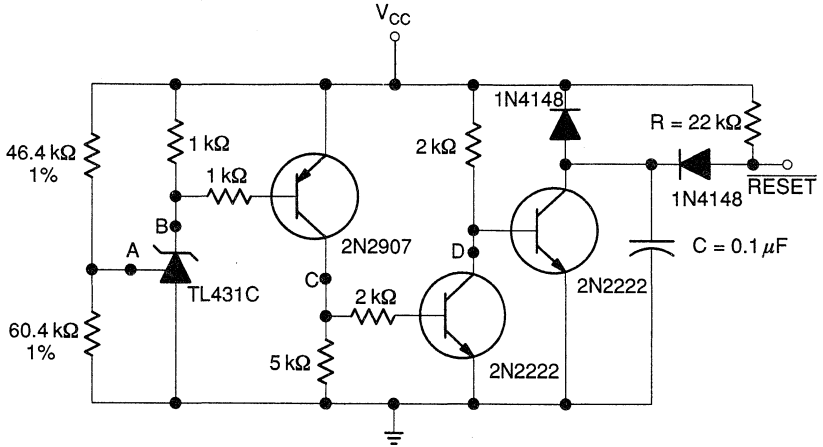
**CAUTION**  
 Capacitors should not discharge directly into the  $\overline{\text{RESET}}$  pin. Protect this pin from damage by using a diode such as D1 as shown in Figure 5–5.

### 5.2.2 Reset Circuitry with Low-voltage Detection

It is often desirable to have the device assert  $\overline{\text{RESET}}$  during low-power or brownout conditions. In these instances an active reset circuit with a low voltage detection feature may be connected to the  $\overline{\text{RESET}}$  pin. Devices incorporating EEPROM require that the external  $\overline{\text{RESET}}$  pin must be active (low) while  $V_{CC}$  is below its minimum specified operating level to ensure the integrity of the EEPROM contents. Active reset circuitry prevents the EEPROM contents from being corrupted by improper instruction execution due to insufficient  $V_{CC}$  supply voltage and insures that the EEPROM write control registers (DEECTL, PEECTL) power-up in the correct state when  $V_{CC}$  returns to its specified operating range.



**Figure 5–6. Typical Reset Circuit with Low-voltage Detection**



The circuit illustrated in Figure 5–6 is a typical circuit that could be used to cause a system reset in the event of a low-voltage condition. This circuit will pull the  $\overline{\text{RESET}}$  pin low when  $V_{CC}$  falls below 4.5 V and will not allow  $\overline{\text{RESET}}$  to go high until  $V_{CC}$  rises above 4.5 V. The trip point for the low-voltage condition can be modified by changing the values of the appropriate circuit elements. The basic operation of this circuit is centered around the TL431C precision voltage regulator. This regulator will not conduct if the trip point (Node A) is less than 2.5 V. As long as  $V_{CC}$  stays above approximately 4.5 V, the regulator will have greater than 2.5 V applied to Node A through the  $R_a/R_b$  divider network. When  $V_{CC}$  falls below 4.5 V, Node A will also fall below 2.5 V.

The RC network of 22 k $\Omega$  and 0.1  $\mu\text{F}$  provides a power-up rise time. Depending on the rise time of the power supply you are using, this may not be necessary. The two diodes (1N4148) are needed since the reset of the TMS370 device can also be pulled low internally by the Watchdog counter as well as other circuits. The diodes are used to prevent the capacitor from discharging directly to the  $\overline{\text{RESET}}$  pin when it is pulled low internally. Also the diode connected from the capacitor to  $V_{CC}$  provides an additional path for the capacitor to discharge when  $V_{CC}$  goes low suddenly.



Introduction	1
Assembly Language Instruction Set	13
TMS370 Family Devices	2
Design Aids	14
CPU and Memory Organization	3
Development Support	15
System and Digital I/O Configuration	4
Electrical Specifications	16
Interrupts and System Reset	5
Customer Information	17
EEPROM Modules	6
Appendices	A-H
Timer 1 Module	7
Timer 2 Module	8
Serial Communications Interface (SCI) Port	9
Serial Peripheral Interface (SPI) Module	10
Analog-to-Digital Converter Module	11
TMS370 Programmable Acquisition and Control Timer	12



# EPROM and EEPROM Modules

---

---

---

This chapter discusses the architecture and programming of the Data EEPROM modules of the TMS370 family and the Program EPROM and EEPROM module on the TMS370C7xx and TMS370C8xx devices. Additional information about these modules is included in Chapter 14, Design Aids and Chapter 16, Electrical Specifications.

This chapter covers the following topics:

<b>Section</b>	<b>Page</b>
6.1 Data EEPROM Module .....	6-2
6.2 Program EEPROM Module .....	6-9
6.3 Program EPROM Module .....	6-12

## 6.1 Data EEPROM Module

The TMS370 Data EEPROM module contains a 256-byte array configured into eight 32-byte blocks. Devices may have multiple 256-byte arrays. Each additional array is also configured with eight 32-byte blocks. The first byte of each 256-byte array is the Write Protect Register (WPR) for that array. This module also contains a voltage generator which provides a special precise programming voltage to the EEPROM array. This special voltage helps increase the reliability of the EEPROM and allows the TMS370 to program the EEPROM with a single  $V_{CC}$  voltage source. Each EEPROM module contains a voltage generator so a routine can simultaneously program a byte of Data EEPROM and a byte of Program EEPROM without conflict.

Reading the EEPROM module is identical to reading other internal memory and takes two system clock cycles. The CPU can fetch data and execute instructions from the EEPROM arrays. The Data EEPROM module can be programmed on array, a byte, or single-bit basis. The memory can also be protected from inadvertent writing with a write-protect feature.

The Data EEPROM is controlled by the DEECTL register and the Write Protect Register (WPR). The Data EEPROM control register (DEECTL) contains the bits needed to initiate and monitor EEPROM programming. The Write Protect Register (WPR), of the given array, contains the write protection bits for each 32-byte block of that Data EEPROM array.

6

### 6.1.1 Control Registers

The Data EEPROM can be write protected, block by block (32 bytes), with the WPR register(s). The DEECTL register determines the mode of programming and when programming is initiated.

#### 6.1.1.1 Write Protection Register (WPR)

The WPR register(s) provide write protection for the Data EEPROM contents. The WPR is located as the first byte of each 256-byte Data EEPROM array. The WPR itself is located in BLK0 of this array, generally at location 1x00h (where x is in the range 1 to F). This implies that the WPR, for the 256-byte array, is itself protected whenever BLK0 of that array is protected.

There are eight blocks of equal size in the Data EEPROM array. Each bit in the WPR corresponds to one of the blocks. Programming a bit in this register to a 1 protects the corresponding block. Figure 6-1 shows the block protected by each bit.

Once block 0 is protected, the write-protection configuration can not be altered unless write protection is overridden by placing the microcomputer into the Write Protection Override mode (12 volts on the MC pin). There is



### 6.1.1.2 Data EEPROM Control Register (DEECTL)

The DEECTL Register is located in the peripheral file at address P01A (101Ah). Data EEPROM programming is controlled through this register. The following figure illustrates the bit definitions for the DEECTL register.

**Data EEPROM Control Register (DEECTL)**  
**[Memory Address - 101Ah]**

BIT#-	7	6	5	4	3	2	1	0
P01A	BUSY	—	—	—	—	AP	W1W0	EXE
	R-*					RW-0	RW-0	RW-0

R=Read, W=Write, -n=Value after reset (\* -see Bit 7 description)

- Bit 0 - **EXE.** Execute.  
 Set this bit to initiate the write operation defined by the remaining control register bits. Clear this bit to terminate a programming operation in progress. If the application program reads a Data EEPROM location while the EXE bit is set, the processor reads the data being programmed into the EEPROM. If software attempts a write to the EEPROM while the EXE bit is set, the data byte is ignored.

0 = Inactive.  
 1 = Active.
- Bit 1 - **W1W0.** Write1/Write0.  
 This bit determines whether the Ones or Zeroes programming mode is to be used (see Section 6.1.2). This bit is write protected whenever the EXE bit is set.

0 = Write zeros.  
 1 = Write ones.
- Bit 2 - **AP.** Array Program.  
 Set this bit to program the entire array with the value specified by the W1W0 bit in a single programming cycle (refer to Chapter 16 for timing). Blocks protected in the WPR register are *not* programmed. For devices with multiple 256 arrays, the device must be in the WPO mode for the array to be programmed. If the device is not in the WPO mode, the AP bit has no effect on the programming operation and a single bite is programmed. This bit is write protected whenever the EXE bit is set.

If BLK0 is unprotected and W1W0 is zero, this function clears the WPR; any array locations previously protected will lose their protection, but their contents are not altered during the current programming cycle.

0 = Array programming disabled.  
 1 = Array programming enabled.
- Bit 3–6 - Reserved. Read data is indeterminate.

6



Bit 7 -

**BUSY.**

This bit is set during Data EEPROM programming to indicate that an operation is in progress. Reading any location of the EEPROM during programming returns the data being programmed. In order to let the EEPROM voltages stabilize, the BUSY bit is set for 128 cycles:

- 1) after a reset,
- 2) after an exit from a power-down state, and
- 3) after programming the EEPROM.

If an attempt is made to access the EEPROM during this 128 cycle period, the Data EEPROM holds execution of the processor by asserting the WAIT signal until the 128 cycles is complete.

0 = EEPROM array is ready for access.

1 = EEPROM array is not ready for access.

## 6.1.2 Programming the Data EEPROM

The procedure for programming the Data EEPROM is controlled by the DEECTL (P01A) register and the associated array's WPR (1x00h) register. Individual bits are programmed to a 1 or 0 under the control of the W1W0 bit and the EXE bit in the DEECTL register. When the W1W0 bit is set, bit positions set to 1 in the data byte are programmed to 1 in the EEPROM byte; zeros are not changed. When the W1W0 bit is cleared, bit positions set to 0 in the data byte are programmed to 0 in the EEPROM byte; ones are not changed. The EXE bit initiates EEPROM programming when set and disables programming when cleared. The WPR (1x00h) registers must have the corresponding protection bit cleared or be in the WPO mode to enable a Data EEPROM write operation. (To enter the WPO mode, place 12 volts to the MC pin while the RESET pin is a logic 1.)

To load the data byte into the EEPROM module, perform a memory write operation to the EEPROM at the desired address. The data byte is latched in the module, ready for the Execute command (EXE bit=1).

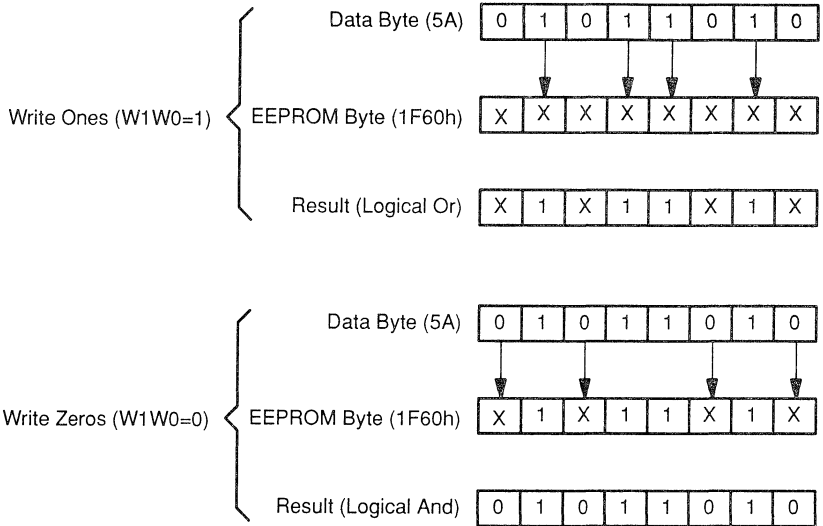
Following the memory cycle to the EEPROM address, write 03h (for W1W0=1) or 01h (for W1W0=0) to the DEECTL register to set the W1W0 and EXE bits. The W1W0 and the EXE bits must remain unchanged for the duration of the EEPROM timing parameter of  $t_{W(PGM)B}$  to insure proper programming. When the program time has elapsed, reset the EXE bit with another write operation to the DEECTL register.

If W1W0=1, then the data which now resides in the programmed EEPROM location is the logical OR of the previous data stored in the location and the data written to the location. If W1W0=0, then the data which now resides in the programmed EEPROM location is the logical AND of the previous data stored in the location and the data written to the location.

If a data value cannot be achieved by writing only ones or zeros, first perform the write-ones operation and follow it with a write zeros operation (or write

zeros followed by write ones). Figure 6–2 illustrates these operations. In the programming operations, only the EEPROM bits that do not match the data bits are programmed. Therefore, there is no need to read the EEPROM value to determine what bits to program.

**Figure 6–2. EEPROM Programming Example**



The software should end the programming operation before entering a Halt or Standby state. When the microcomputer is in the Halt or Standby low-power mode, all operations of the data EEPROM module are stopped and all DEECTL bits are cleared. Any EEPROM programming operation in progress is aborted when the halt is entered, and the data at the address being programmed is indeterminate.

**Example 6–1. Data EEPROM Programming Example**

The following subroutine loads the data byte 5A into the Data EEPROM location 1F60h. Figure 6–2 illustrates the result of this subroutine.

6

```

(a) DATA  MOV    #5Ah,A      ;Write 5A to location 1F60h
          MOV    A,1F60h
(b)        MOV    #03,P01A   ;Write Ones: W1W0=1, EXE=1
(c)        MOVW   #2778,R017;Begin tW(PGM)B delay (10 ms)
(d) DELAY1 INCW   #-1,R017  ;Decrement R017
(e)        JC     DELAY1    ;Jump to DELAY1 if R017>0
(f)        MOV    #0,P01A   ;Clear DEECTL. EXE=0
(g)        MOV    #01,P01A  ;Write zeros: W1W0=0 EXE=1
(h)        MOVW   #2778,R017;Begin tW(PGM)B delay (10 ms)
(i) DELAY2 INCW   #-1,R017  ;Decrement R017
(j)        JC     DELAY2    ;Jump to DELAY2 if R017>0
(k)        MOV    #0,P01A   ;Clear DEECTL. EXE=0
          .
          .
          .

```

Load the value 5A into the Data EEPROM address 1F60h (a). Begin a Write Ones programming sequence by (b) setting the W1W0 and EXE bits in the DEECTL register to a 1. The programming delay parameter  $t_W(\text{PGM})B$  (10 ms for this example — see Chapter 16 for required timing) is taken care of with a delay loop (d,e). The number of loops required is #2778 (c), and can be derived in the following manner:

- Delay loop (d,e) requires 18 cycles to complete if a jump is taken.
- An operating frequency of 20 MHz results in a system cycle time of 200 ns.
- The number of loops required is calculated as follows:

$$\text{loop count} = t_W(\text{PGM})B / (\text{system cycle time} \times \text{delay loop cycle count})$$

$$\text{loop count} = 10 \text{ ms} / (200 \text{ ns} \times 18) = 10 \text{ ms} / 3.6 \text{ } \mu\text{s} = 2778$$

Note: alternatively, a timer may be used for this delay.

After the delay, clear the EXE bit (f), and continue the Write Zeros routine (g through k). The value 5A has now been programmed into location 1F60h of the Data EEPROM.

The BUSY bit is set during EEPROM programming to indicate an operation in progress. Reading any location of the Data EEPROM during programming returns the data being programmed. In order to let the EEPROM voltages stabilize, the BUSY bit remains set for 128 cycles:

- after a reset,
- after exit from a power-down state, and
- after programming the EEPROM.

If an attempt is made to access the EEPROM during this 128 cycle period, the Data EEPROM holds execution of the processor by asserting the WAIT signal until the 128 cycles is complete.

### 6.1.3 Write Protection Register Operation

The Write Protection Register (WPR) allows the application program to guard any or all of the eight blocks of EEPROM shown in Figure 6–1. Each block has a representative bit in the WPR. The blocks to be protected have their corresponding bit set in the WPR. Block zero contains the WPR. Therefore, once the bit for block zero (BLK0) is set, WPR can no longer be changed unless the Write Protect Override mode is entered.

The following example illustrates programming the WPR. In this example, the program protects blocks 0 and 2.

```
MOV      #05,A           ;Protect bits for BLK0 and BLK2
MOV      A,1F00h        ;Set DEECTL to program 1's
MOV      #3,P01A        ;Set W1W0 and EXE bits
MOVW    #2778,R011     ;10 ms delay loop
DELAY   INCW            #-1,R011
        JC             DELAY
MOV      #0,P01A        ;Clear W1W0 and EXE bits
```

See Chapter 14 for more examples of programming the EEPROM module.

## 6.2 Program EEPROM Module

The following is a description of the Program EEPROM module used in the TMS370 family. This module serves in place of the program ROM (TMS370C8xx devices) for systems in prototype and small production runs.

The module consists of a 4-kilobyte array of EEPROM at address locations 7000h through 7FFFh. The CPU can fetch data and execute instructions from this memory space. Programming control logic for the Program EEPROM is located at address 101Ch (P01C).

The CPU accesses the array with normal memory read cycles. Write cycles to the Program EEPROM require a special sequence of events. This sequence is similar as that for the Data EEPROM, except that the PEECTL register (P01C) is used for control and there is no Write Protection Register for the Program EEPROM.

The Program EEPROM module can only be written to when the TMS370 device is operating in the Write Protect Override mode (12 volts on the MC pin). A read access to the Program EEPROM during a WPO programming operation, returns the data being programmed.

### 6.2.1 Program EEPROM Control Register (PEECTL)

The PEECTL register, at address 101Ch in the peripheral file, controls programming of the Program EEPROM. The following figure illustrates the bit definitions for the PEECTL.

**Program EEPROM Control Register (PEECTL)**  
[Memory Address —101Ch]

BIT#-	7	6	5	4	3	2	1	0
P01C	BUSY	—	—	—	—	AP	W1W0	EXE
	R-*					RW-0	RW-0	RW-0

R=Read, W=Write, -n=Value after reset (\* -see Bit 7 description)

**Bit 0 - EXE. Execute.**  
Set this bit to initiate the write operation defined by the other control register bits. Clear this bit to terminate the operation.

0 = Inactive.  
1 = Active.

**Bit 1 - W1W0. Write1/Write0.**  
This bit determines whether the Ones or Zeroes programming mode is to be used. This bit is write protected when EXE=1.

0 = Write zeros.  
1 = Write ones.

**Bit 2 - AP. Array Program.**  
Set this bit to program the entire array with the value specified by the W1W0 bit. With this function, large sections of EEPROM can be altered in a fraction of the time necessary to program byte by byte. This bit is write protected when EXE=1.

0 = Array programming disabled.  
1 = Array programming enabled.

**Bit 3–6 - Reserved.** Read data is indeterminate.

**Bit 7 - BUSY.**  
This bit is set during EEPROM programming to indicate that an operation is in progress. Reading any location of the EEPROM during programming returns the data being programmed. In order to let the EEPROM voltages stabilize, the BUSY bit is set for 128 cycles:

- 1) after an exit from a power-down state, or
- 2) after programming the EEPROM.

If an attempt is made to access the EEPROM during this 128 cycle period, the Program EEPROM holds execution of the processor by asserting the WAIT signal until 128 cycles complete.

0 = EEPROM array is ready for access.  
1 = EEPROM array is not ready for access.

6

## 6.2.2 Programming the Program EEPROM

The procedure to program this EEPROM module is similar to the procedure described in Section 6.1.2 with the following differences.

- ❑ The PEECTL register (address P01C in the peripheral file) controls the Program EEPROM.
- ❑ There is no write-protection register. The Program EEPROM is write protected at all times unless the TMS370 device is in the Write Protection Override mode.

Before programming, make sure that the programming routine resides in external memory, RAM, or Data EEPROM and that Memory Disable is cleared. Internal program memory must be enabled. The programming sequence is:

- 1) External hardware puts 12 volts on the MC pin to enter the WPO mode after reset.
- 2) Write a data byte to the desired address in the Program EEPROM.
- 3) Write the command byte (03h for programming ones or 01h for programming zeros) to the PEECTL register at address 101Ch.
- 4) Wait for the programming delay time,  $t_W(\text{PGM})_B$  (see Chapter 16, Electrical Specifications).
- 5) Write 00h to the PEECTL register to clear the EXE bit.
- 6) Repeat steps 3 through 6 as necessary to complete the programming.
- 7) External hardware returns the MC pin to its normal value (logic 1 for microprocessor mode or logic 0 for the microcomputer mode).

When the AP bit is set, the entire Program EEPROM is programmed to all ones or all zeros in a single write sequence. When  $W1W0=0$ , all zeros are programmed to the entire Program EEPROM. When  $W1W0=1$ , all ones are programmed to the entire Program EEPROM. This function is useful for block-erase operations. Issue this command by writing 05h to the PEECTL register to set the AP and EXE bits.

When the TMS370 is in the HALT or STANDBY low-power mode, all operations of the Program EEPROM are stopped. All programming operations should be completed before entering a HALT or STANDBY state. Any EEPROM programming operation, in progress at the time that the halt is entered, is aborted. The data at the address being programmed is indeterminate. See Chapter 14 for actual program example.

## 6.2.3 Write Protection of Program EEPROM

The Program EEPROM memory is always write protected unless the device is put into the Write Protect Override (WPO) mode by applying 12 volts to the MC pin while the  $\overline{\text{RESET}}$  pin is a logic 1. When the device is in the WPO mode, all Program and Data EEPROM memory can be overwritten.

### 6.3 Program EPROM Modules

The following is a description of the Program EPROM modules used in the TMS370 family. These modules replace the 4 K, 8 K, or 16 Kbyte program ROM within the TMS370 families for system prototypes or small production runs. Initially these devices are offered in a windowed package, for multiple programming iterations, with plans to also include OTP versions. Call the local field sales office or the 8-bit Microcontroller Technical Hotline for latest product status information.

These modules consist of a 8-Kbyte array as well as a 16-Kbyte array of EPROM at address locations 6000h through 7FFFh and 4000h through 7FFFh respectively. The CPU can fetch data and execute instructions from this memory space. Programming control register for the Program EPROM is located at address 101Ch (P01C).

The CPU accesses the array with normal memory read cycles. Write cycles to the Program EPROM require a special sequence of events. This sequence is described in Section 6.3.2.

An external supply ( $V_{PP}$ ) is needed at the MC<sub>PP</sub> pin to provide the necessary voltage  $V_{PP}$  for programming. Programming is controlled through a register (EPCTL) in the peripheral file.

Before programming (windowed versions), the EPROM MODULE is erased by exposing the device through the transparent window to high-intensity ultraviolet light (wavelength 2537 angstroms). The recommended minimum exposure dose (UV intensity x exposure time) is 15 watt-seconds per square centimeter. A typical 12 milliwatt-per-square-centimeter, filterless UV lamp will erase the device in 21 minutes. The lamp should be located about 2.5 centimeters above the chip during erasure. After erasure, the entire array is at logic 1 state. A programmed 0 can be erased to 1 only by exposure to ultraviolet light. It should be noted that normal ambient light contains the correct wavelength for erasure. Therefore, when using a programmed device, the window should be covered with an opaque label. All devices are erased to logical 1 upon delivery from the factory.

**Exposing the EPROM module to the ultraviolet light may also cause erasure in any EEPROM module. Any useful data stored in the EEPROM must be reprogrammed after exposure to UV light.**

**CAUTION**



### 6.3.1 Program EPROM Control Register (EPCTL)

The EPCTL register, at address 101Ch in the peripheral file, controls programming of the Program EPROM. The following figure illustrates the bit definition for the EPCTL.

**Program EPROM Control Register (EPCTL)**  
[Memory Address – 101Ch]

BIT#-	7	6	5	4	3	2	1	0
P01C	BUSY	VPPS	—	—	—	—	W0	EXE
	R-0	RW-0					RW-0	RW-0

R=Read, W=Write, -n=Value after reset

- Bit 0 - **EXE.** Execute.  
Set this bit to initiate the write operation defined by the other control register bits. Clear this bit to terminate the operation.  
  
0 = Inactive.  
1 = Active.
- Bit 1 - **W0.** Write 0.  
This bit determines whether the programming of the zero bits (in the byte written) is enabled.  
  
0 = programming of 0 bits enabled.  
1 = programming of 0 bits disabled.
- Bit 2–5 - Reserved.
- Bit 6 - **VPPS.**  
This bit determines whether the programming voltage  $V_{PP}$  at the MC pin is connected to the EPROM module.  
  
0 = programming disabled  
1 = programming enabled.
- Bit 7 - **BUSY.**  
This bit reflects the value of the EXE bit.

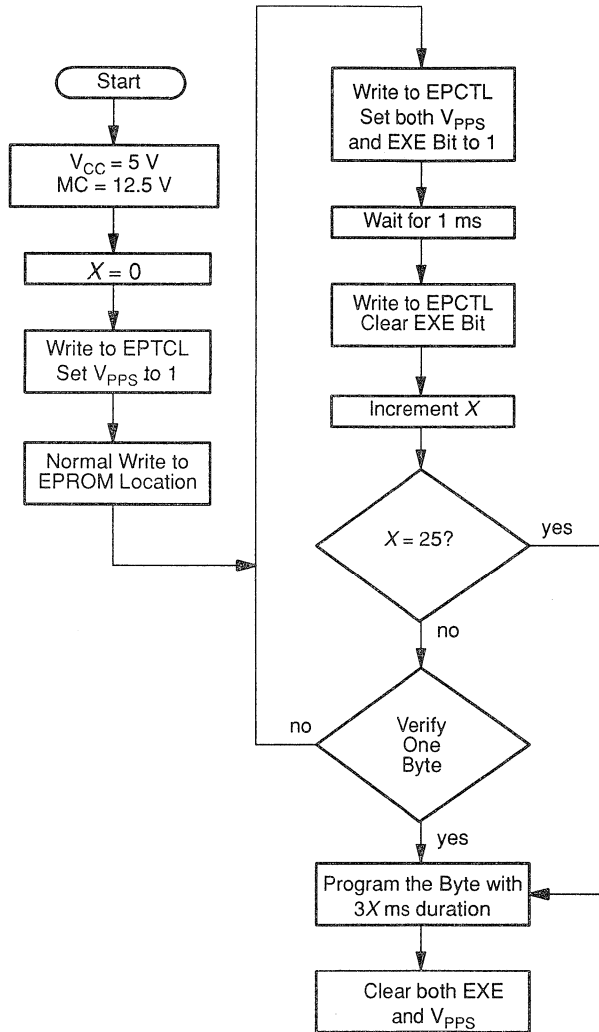
### 6.3.2 Programming the Program EPROM

The procedure to program the EPROM module is described below.

Programming 0 to the EPROM is controlled by the EPCTL register via the EXE bit and the  $V_{PPS}$  bit. The EXE bit initiates EPROM programming when set and disables programming when cleared. The  $V_{PPS}$  connects the programming voltage  $V_{PP}$  at the MC pin to the EPROM module.  $V_{PPS}$  (EPCTL.6) and EXE (EPCTL.0) should be set separately, and the  $V_{PPS}$  bit should be set at least two microseconds before the EXE bit is set. After programming, the application programming should wait for four microseconds before any read attempt is made. The programming operation (see Figure 6–3) is performed in the following suggested sequence:

- 1) Supply the programming voltage to the MC pin.
- 2) Write to the EPCTL to set the  $V_{PPS}$  bit to 1.
- 3) Perform normal memory write to the target EPROM location.
- 4) Write to the EPCTL to set the EXE bit to 1. (Wait at least two microseconds after step 2.)
- 5) Wait for program time to elapse (one millisecond).
- 6) Write to the EPCTL to clear the EXE bit (leave  $V_{PPS}$  set to 1).
- 7) Read the byte being programmed; if correct data is not read, repeat steps 4 through 6  $X$  times up to a maximum of 25.
- 8) Write to the EPCTL to set the EXE bit to 1 for Final programming.
- 9) Wait for program time to elapse ( $3X$  milliseconds duration).
- 10) Write to the EPCTL to clear the EXE and  $V_{PPS}$  bits.

Figure 6-3. EPROM Programming Operation



6

An external power supply at  $V_{PP}$ ,  $I_{PP}$  (30 mA) is required for programming operation. Programming voltage  $V_{PP}$  is supplied via the MC pin. This also automatically puts the microcontroller in the Write Protection Override (WPO) mode. Programming voltage may be applied via the MC pin anytime after reset and remain at  $V_{PP}$  after programming (after the EXE bit is

cleared). Applying programming voltage while RESET is active will put the microcontroller in reserved mode, where programming operation is inhibited.

### 6.3.3 Write Protection of Program EPROM

To override the EPROM write protection the  $V_{PP}$  voltage must be applied to the MC pin **and** the  $V_{PPS}$  bit (EPCTL.6) must be set. This dual requirement ensures that the Program EPROM will not accidentally be overwritten during Data EEPROM operations when  $V_{PP}$  is applied to the MC pin. Data EEPROM may be programmed when the  $V_{PPS}$  bit is set.

Introduction	1
Assembly Language Instruction Set	13
TMS370 Family Devices	2
Design Aids	14
CPU and Memory Organization	3
Development Support	15
System and Digital I/O Configuration	4
Electrical Specifications	16
Interrupts and System Reset	5
Customer Information	17
EEPROM Modules	6
Appendices	A-H
Timer 1 Module	7
Timer 2 Module	8
Serial Communications Interface (SCI) Port	9
Serial Peripheral Interface (SPI) Module	10
Analog-to-Digital Converter Module	11
TMS370 Programmable Acquisition and Control Timer	12



# Timer 1 Module

---

---

---

This chapter discusses the architecture and programming of the Timer 1 module of the TMS370 family and covers the following topics:

<b>Section</b>	<b>Page</b>
7.1 Timer 1 Overview .....	7-2
7.2 Timer 1 Operation .....	7-7
7.3 Watchdog Timer .....	7-19
7.4 Low-Power Modes .....	7-23
7.5 Timer 1 Control Registers .....	7-24

## 7.1 Timer 1 Overview

The Timer 1 module of the TMS370 family provides enhanced timer resources to perform real-time system control. The Timer 1 Overview contains the following subsections:

- 7.1.1 Introduction: Describes Timer 1 functions and features.
- 7.1.2 Major Components: Illustrates Timer 1 system components.
- 7.1.3 Operating Modes Overview: Describes operating modes of the Timer 1 module.

### 7.1.1 Introduction

This module contains a general-purpose timer (T1) and a Watchdog timer (WD). Both T1 and WD allow program selection of input clock sources (real-time, external event, or pulse accumulate) with multiple 16-bit registers (input capture and compare) for special timer function control. These timers provide the capabilities for:

#### System Requirements

Real-Time System Control  
 Input Pulse Width Measurement  
  
 External Event Synchronization  
 Timer Output Control  
 Pulse-Width Modulated Output Control  
 System Integrity

#### Timer Resource

Interval Timers with Interrupts  
 Pulse Accumulate or Input Capture Functions  
 Event Count Function  
 Compare Function  
 PWM Output Function  
  
 Watchdog Function

7

#### FEATURES

- ☐ 16-bit General Purpose Counter
  - 16-bit Compare Register
  - 16-bit Capture/Compare Register
  - External Clock Source/Event Counter/Pulse Accumulator
  - Internal or External Counter Reset
  - Programmable Pulse Width Modulated (PWM) Output
- ☐ Selectable Edge Detection Input
- ☐ Programmable Interrupts
- ☐ Three I/O Pins
- ☐ Watchdog Timer



## 7.1.2 Major Components

The Timer 1 module consists of three major blocks as shown in Figure 7–1:

**Prescaler/Clock Source** which determines the independent clock sources for the general purpose timer and the watchdog timer.

**16-bit General Purpose Counter** which provides capture, compare and event functions.

- ❑ The capture function latches the counter value on the occurrence of an external input.
- ❑ The event function keeps a cumulative total of the transitions on the T1EVT pin.
- ❑ The compare function triggers when the counter matches the contents of a compare register.

**16-bit Watchdog Counter** which software can reconfigure as a simple counter/timer, an event counter, or a pulse accumulator if the watchdog feature is not needed.

The Timer 1 module contains additional blocks as follows:

### Interrupts

The module can be programmed to issue interrupts on the occurrence of a:

- ❑ capture,
- ❑ compare equal,
- ❑ counter overflow, or
- ❑ external edge detect.

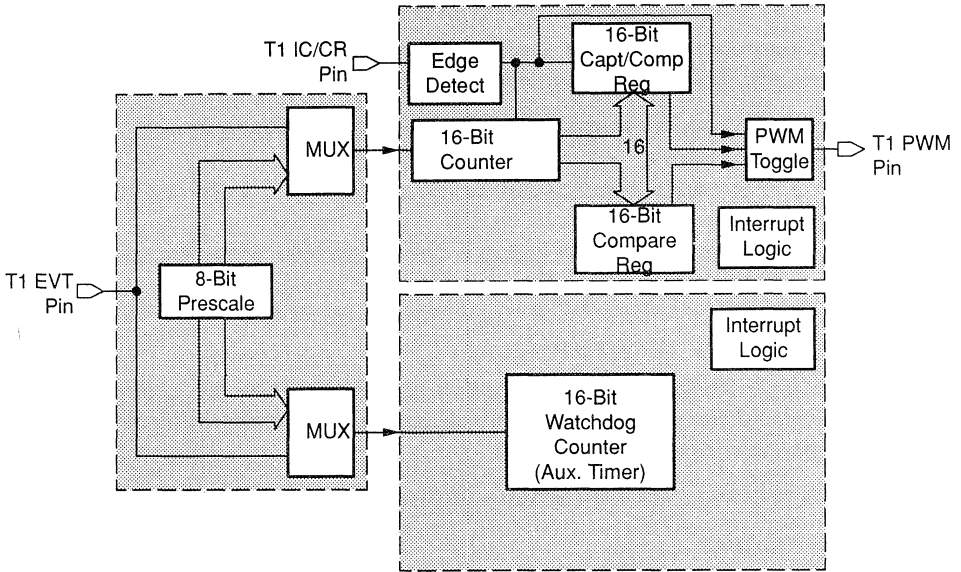
### I/O Pins

The Timer 1 Module has three I/O pins which can be dedicated for timer functions or as general purpose I/O pins. They are:

- ❑ T1EVT
- ❑ T1IC/CR
- ❑ T1PWM

When these pins are dedicated to the timer module, T1EVT is an input to the event counter or the external clock source; T1IC/CR is an input to the input capture, counter reset, or PWM circuit; and T1PWM is the Pulse Width Modulation output.

**Figure 7–1. Timer 1 Block Diagram**



**7**

**Table 7–1. Timer 1 I/O Pin Definitions**

Pin	Dual Compare Mode	Capture/Compare Mode
T1C1/CR	Counter Reset Input	Input Capture 1 Input
T1PWM	PWM Output	PWM Output
T1EVT	External Event Input or Pulse Accumulate Input	External Event Input or Pulse Accumulate Input

**Note:** Pins may be used as general purpose I/O if not dedicated for timer functions.

### Control Registers

Seven addressable control registers govern Timer 1. These registers:

- select the operating mode,
- enable interrupts,
- configure status flags,
- configure the I/O pins, and
- select the prescaler tap.

Timer 1 control registers (shown in Table 7–2 and described further in Section 7.5) are located at addresses P040 (1040h) to P04F (104Fh) in the peripheral file. The location and name of each register is shown in Table 7–2.

**Table 7–2. Timer 1 and Watchdog Counter Memory Map**

Peripheral File Location	Symbol	Name
P040 P041	T1CNTR	Counter – MSB Counter – LSB
P042 P043	T1C	Compare Register – MSB Compare Register – LSB
P044 P045	T1CC	Capture/Compare Register – MSB Capture/Compare Register – LSB
P046 P047	WDCNTR	Watchdog Counter – MSB Watchdog Counter – LSB
P048	WDRST	Watchdog Reset Key
P049	T1CTL1	Timer 1 Control Register 1
P04A	T1CTL2	Timer 1 Control Register 2
P04B	T1CTL3	Timer 1 Control Register 3
P04C	T1CTL4	Timer 1 Control Register 4
P04D	T1PC1	Timer 1 Pin Control 1
P04E	T1PC2	Timer 1 Pin Control 2
P04F	T1PRI	Timer 1 Priority

### 7.1.3 Operating Modes Overview

The general-purpose Timer 1 module has two modes of operation: the Dual Compare Mode and the Capture/Compare Mode.

#### **Dual Compare Mode**

The counter is configured to provide two compare registers, external or software reset of the counter, internal or external clock source, and a programmable Pulse Width Modulated (PWM) output. The PWM output may be configured to toggle on selected events.

#### **Capture/Compare Mode**

The counter is configured to provide one input capture register and one compare register for use with the general purpose timer. The compare register may be used to provide periodic interrupts to the TMS370 CPU. The capture register may be configured to capture the current counter value upon either edge of an external input.

## 7.2 Timer 1 Operation

This section describes the elements of the 16-bit General Purpose Timer (T1). The function of each block within T1 is discussed in general and for each mode of operation. Section 7.2 contains the following subsections:

- 7.2.1 General-Purpose Timer Operating Modes: Explains theory of operating modes.
- 7.2.2 Clock Prescaler/External Clock Source: Illustrates operation of the Prescaler and clock source selection circuitry.
- 7.2.3 Edge Detection: Explains operation of the External Edge Detection circuitry for both operating modes.
- 7.2.4 General Purpose Counter: Explains operation of the free running Timer 1 up counter.
- 7.2.5 Compare Register: Explains operation of the 16-bit Compare register.
- 7.2.6 Capture/Compare Register: Explains operation of the Capture/ Compare register during both operating modes.
- 7.2.7 Interrupts: Explains interrupting capability for both operating modes.

### 7.2.1 General Purpose Timer Operating Modes

The General Purpose Timer operation mode determines whether the Capture/Compare register functions as a capture register in the Capture/Compare mode or as a compare register in the Dual Compare mode. The T1 MODE bit (T1CTL4.7) selects the mode as follows:

T1 MODE = 0 - Dual Compare Mode

T1 MODE = 1 - Capture/Compare Mode

#### Dual Compare Mode

The Dual Compare Mode provides two compare registers, an external-resettable counter, and a timer output pin. These allow the timer to act as an interval timer, a PWM output, simple output toggle, or many other timer functions.

The Dual Compare mode as shown in Figure 7–3 continuously compares the contents of the two compare registers to the current value of the 16-bit counter. If a timer compare register equals the counter, the circuit sets the associated interrupt flag to 1 and toggles the T1PWM output pin if enabled, and/or generates a Timer 1 interrupt.

A compare-equal condition from compare register 1 can also initiate a counter reset. A programmable-interval timer function (selected by using

the compare equal condition to generate a system interrupt combined with the counter reset function) generates a periodic interrupt.

Either compare function may be used to toggle the T1PWM output pin when a compare-equal condition occurs, while the other compare function may be used for another system timing function. Using both compare functions to control the T1PWM pin allows direct PWM generation with minimal CPU software overhead.

In typical PWM applications, the compare register is loaded with the periodic interval and configured to allow counter reset on a compare-equal condition, and the Capture/Compare register is loaded with the pulse width to be generated within that interval. The program pulse width may be changed by the application program during the timer operation to alter the PWM output. For high-speed control applications, a minimum pulse width of 200 ns and a period as low as 400 ns can be maintained when using a CLKIN of 20 MHz.

In addition, the PWM output can be used to support time-critical control applications. Typically, in these applications an external input (T1IC/CR) is used to:

- 1) reset the counter,
- 2) generate a timer interrupt, and
- 3) toggle the T1PWM pin to start the PWM output.

The compare function then toggles the output after the programmed pulse width has elapsed.

The input edge detect function is enabled under program control by the T1CR DET ENA bit, and upon the next occurrence of the selected edge transition:

- 1) the T1EDGE INT FLAG bit is set,
- 2) a timer interrupt is generated (if T1EDGE INT ENA = 1), and
- 3) the T1PWM output pin is toggled (if T1CR OUT ENA = 1).

The T1EDGE POLARITY bit selects the active input transition. In the Dual Compare mode, the edge detect function must be re-enabled after each valid edge detect.

The clock input to the counter is either the internal system clock, with or without prescale, or the external clock (T1EVT). The clock pulse to the counter is always synchronized with the system clock.

7



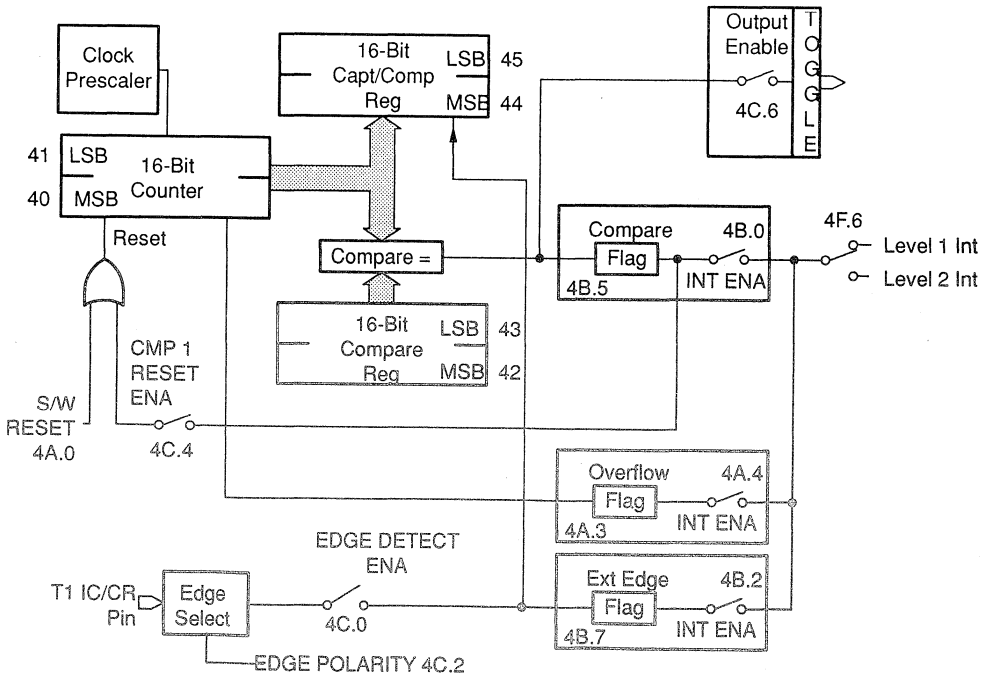
### Capture/Compare Mode

In the Capture/Compare mode (T1 MODE = 1), Timer 1 provides one input capture register for external timing and pulse-width measurement, and one compare register for use as a programmable interval timer. In this mode, the compare register functions the same as in the Dual Compare mode described previously, including the ability to toggle the PWM pin. The capture/compare register functions in this mode as a 16-bit input capture register, as shown in Figure 7-3. On the occurrence of a valid input on the T1IC/CR pin:

- 1) the current counter value is loaded into the 16-bit input capture register,
- 2) the T1EDGE INT FLAG is set, and
- 3) a timer interrupt is generated (if T1EDGE INT ENA = 1).

The input detect function is enabled by the T1EDGE DET ENA bit, with T1EDGE POLARITY selecting the active input transition. In the Capture/Compare mode, the edge detect function, once enabled, remains enabled following a valid edge detect.

Figure 7-3. Capture/Compare Mode



7



## 7.2.2 Clock Prescaler/External Clock Source

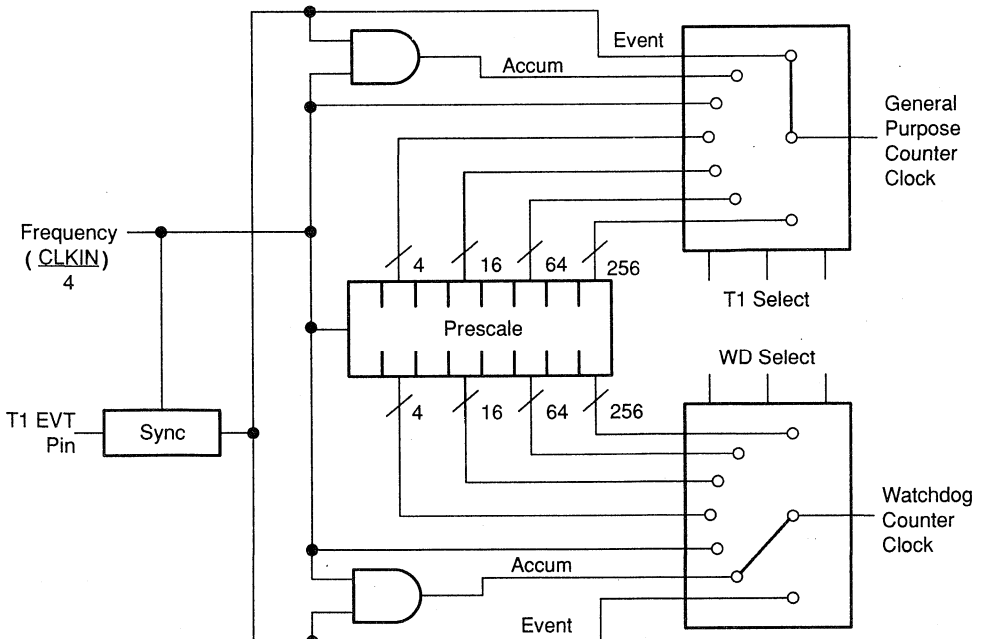
This block, as illustrated in Figure 7–4, allows selection of the clock inputs to the General Purpose Counter and the Watchdog Counter independently. Each counter has three bits in the T1CTL1 Register (see Section 7.5.1) which determine whether the counter is clocked by one of the prescaled system clock values or the external clock source (T1EVT).

The counter clock sources are as follows:

- system clock with no prescale.
- no clock (the counter is stopped).
- external source synchronized with the system clock (event counter operation).
- system clock while the external input is high (pulse accumulation).
- one of four taps from the prescaler which provide a system clock divided by 4, 16, 64, or 256.

The external clock input to the module (T1EVT) must not exceed  $CLKIN/8$ . If the application does not require the external clock, the T1EVT pin may be reconfigured as a digital I/O pin.

**Figure 7–4. Timer 1 System Clock Prescaler**



The event input is not routed through the prescaler; so the Timer 1 module can use different taps of the prescaler for Timer 1 and the Watchdog Timer.

The maximum counter duration using the internal clock is determined by the internal system clock time (SYSCLK) and the prescale tap. These relationships are shown below:

$$\begin{aligned}
 \text{Maximum Counter Duration (seconds)} &= 2^{16} \times \text{PS} \times \text{SYSCLK} \\
 \text{Counter Resolution} &= \text{PS} \times \text{SYSCLK} \\
 \text{where: SYSCLK} &= 4/\text{CLKIN} \\
 \text{PS} &= 1 \text{ for no prescale} \\
 &= 4 \text{ for divide by 4} \\
 &= 16 \text{ for divide by 16} \\
 &= 64 \text{ for divide by 64} \\
 &= 256 \text{ for divide by 256}
 \end{aligned}$$

Table 7-3 gives the real-time counter overflow rates for various crystal and prescaler values.

Software can also configure the overflow rates for the Watchdog Counter as shown in Table 7-3 or the value shown divided by two if the WD OVRFL TAP SEL bit (T1CTL1.7) is set (see Section 7.3). This bit configures the Watchdog Counter as either a 15-bit counter when set or a 16-bit counter when cleared.

7

**Table 7-3. Counter Overflow Rates**

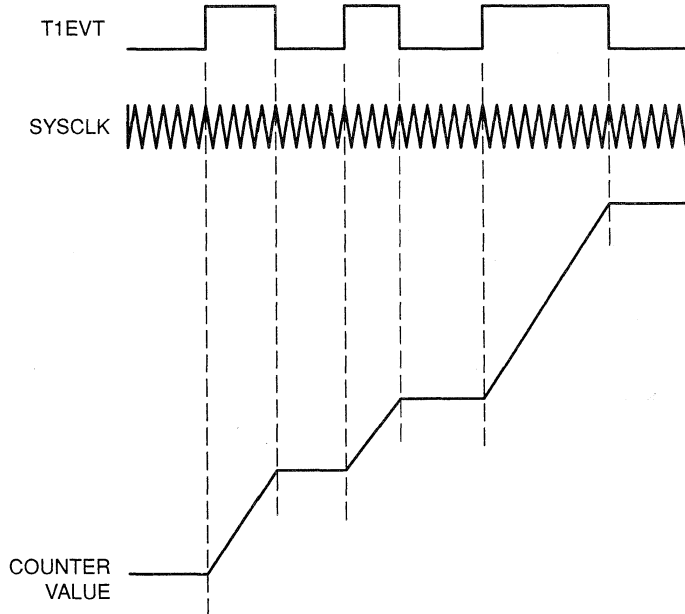
				Crystal Oscillator Frequency (MHz)			
				2.0	4.0	10	20
Select 2	Select 1	Select 0	Divide By	System Clock Period (ns)			
				2000	1000	400	200
0	0	0	2 <sup>16</sup>	0.131 †	0.066	0.026	0.013
0	0	1	(P.A.)	‡	‡	‡	‡
0	1	0	(Event)	‡	‡	‡	‡
0	1	1	(Stop)	‡	‡	‡	‡
1	0	0	2 <sup>18</sup>	0.524	0.262	0.105	0.052
1	0	1	2 <sup>20</sup>	2.10	1.05	0.419	0.210
1	1	0	2 <sup>22</sup>	8.39	4.19	1.68	0.839
1	1	1	2 <sup>24</sup>	33.6	16.8	6.71	3.355

† Time is given in seconds.  
‡ Not applicable.

The event counter input senses a low-to-high transition on the T1EVT pin while in the event-counter mode, and senses a high level (true) on the pin while in the pulse-accumulator mode.

The pulse accumulator mode keeps a cumulative count of SYSCLK pulses gated by the T1EVT signal as shown in Figure 7–5.

**Figure 7–5. Pulse Accumulation**



### 7.2.3 Edge Detection

The edge detection circuitry senses active transitions on the Timer 1 Input-Capture/Counter-Reset pin (T1IC/CR). The T1EDGE POLARITY bit (T1CTL4.2) determines whether the active transition is low-to-high or high-to-low. The module sets the T1EDGE INT FLAG (T1CTL3.7) when an active transition is detected. The program must reset this flag.

#### Dual Compare Mode

In this mode, the program must set the T1EDGE DET ENA bit (T1CTL4.0) to re-enable the circuit after each edge detection. Writing a one to this bit, enables the detect circuit to look for the next correct level transition. After this active transition occurs, the T1EDGE DET ENA bit (T1CTL4.0) is cleared.

When the edge detection circuit is enabled and detects the appropriate edge transition, the T1EDGE INT FLAG bit (T1CTL3.7) is set.

When the T1CR RST ENA bit (T1CTL4.1) is set, the selected edge resets the counter. If the T1CR OUT ENA bit (T1CTL4.3) is set, the selected edge toggles the T1PWM output latch.

The T1EDGE POLARITY bit (T1CTL4.2) determines which edge polarity (rising or falling) is detected.

### **Capture/Compare Mode**

When the appropriate (rising or falling) transition is detected, the edge detection circuit signals the capture register to load the current counter value if the T1 EDGE DET ENA bit is set. The T1EDGE POLARITY bit (T1CTL4.2) determines which edge of the signal on the T1IC/CR pin to detect.

The input detect function is enabled by the T1EDGE DET ENA bit, with T1EDGE POLARITY selecting the active input transition. In the Capture/Compare mode, the edge detect function, once enabled, remains enabled following a valid edge detect.

## **7.2.4 General Purpose Counter**

7

The counter is a free-running, 16-bit up-counter, clocked by the output of the Prescaler/Clock source. During initialization, the counter is loaded with 0000h and begins its up-count. If the counter is not reset before reaching FFFFh, the counter rolls over to 0000h and continues counting. Upon counter roll-over, the T1 OVRFL INT FLAG (T1CTL2.3) is set, and a timer interrupt is generated if the T1 OVRFL INT ENA (T1CTL2.4) bit is set. The program can access the 16-bit compare register at P040 (MSB) and P041 (LSB) in the peripheral file frame.

The counter may be reset to 0000h during counting by either:

- 1) a 1 written to the T1 SW RESET (T1CTL2.0) bit,
- 2) a compare equal condition from the dedicated T1 compare function,
- 3) system reset, or
- 4) an external pulse on the T1IC/CR pin (Dual Compare mode).

The designer may select through software (T1EDGE POLARITY bit) which external transition on the T1IC/CR pin, low-to-high or high-to-low, will reset the counter.

## 7.2.5 Compare Register

The Compare Register circuit consists of a 16-bit wide, read/write data register and logic to compare the counter's current value with the value stored in the compare register. The program can access the 16-bit compare register at P042 (Compare Register MSB) and P043 (Compare Register LSB) in the peripheral file frame (see note in Section 7.5).

When the counter's value matches the compare register value, the following events occur:

- 1) the T1C1 INT FLAG bit (T1CTL3.5) is set,
- 2) the compare register generates a counter reset signal if the T1C1 RST ENA bit (T1CTL4.4) is set,
- 3) the output latch to T1PWM toggles if T1C1 OUT ENA is set, and
- 4) an interrupt is generated if enabled (T1C1 INT ENA).

The compare register is initialized to 0000h following reset.

**Note:**

If the counter is programmed to reset when its value equals the content of the compare register, the reset occurs on the following counter clock cycle (after prescale). However, the compare flag is set and the interrupt event occurs during the clock cycle that incremented the counter to equal the compare equal value. Thus, there could be a delay of up to 256 system clock cycles (depending on the prescale tap in use) from the time the event is recognized by the program until the counter actually resets to zero. If the program writes to the compare register during this interval, the counter may not be reset on the following counter clock cycle.

## 7.2.6 Capture/Compare Register

The Capture/Compare register for Timer 1 is a 16-bit wide register which can serve one of two functions depending on the operating mode. The Capture/Compare register is located at address P044 (Capture/Compare register MSB) and P045 (Capture/Compare register LSB) in the peripheral file (see note in Section 7.5).

### Dual Compare Mode

In the Dual Compare mode, the 16-bit Capture/Compare Register acts as a compare register. This compare register functions exactly as the one described in Section 7.2.5 except that it cannot reset the counter. When an output compare equal occurs, the T1C2 INT FLAG bit (T1CTL3.6) is set.

In the Dual Compare mode, the Capture/Compare register is a read/write register. Compare logic generates a pulse when the the counter value matches the Capture/Compare Register value. This pulse:

- 1) sets the T1C2 INT FLAG bit (T1CTL3.6),
- 2) clocks the output latch to T1PWM if the T1C2 OUT ENA bit (T1CTL4.5) is enabled, and
- 3) generates an interrupt (T1C2) if T1C2 INT ENA (T1CTL3.1) is enabled.

### Capture/Compare Mode

In this mode, the edge detection signal captures the current counter content, loads it into the 16-bit Capture/Compare register, and sets the T1EDGE INT FLAG bit (T1CTL3.7).

### 7.2.7 Timer 1: Compare Register Formula

The Compare Register value required for a specific timing application can be calculated using the following formula:

$$\text{Compare Value} = \frac{t}{\text{PS} \times \text{SYSCLK}} - 1$$

where:

- t = desired timer Compare period (seconds)
- SYSCLK = 4 / CLKIN (external clock frequency)
- PS = 1, 4, 16, 64, or 256 depending on the Prescale Tap selected

Table 7–4 provides some sample Compare Register values to achieve various desired timings using a 20-MHz Crystal.

**Table 7–4. Timer 1 Compare Values: (CLKIN = 20 MHz)**

Time		Prescale	T1 Compare Register Value (N)		% Error (See Note)
Seconds	mSeconds		Decimal	Hex	
0.0005	0.5	None	2499	009C3h	0.000
0.001	1	None	4999	01387h	0.000
0.002	2	None	9999	0270Fh	0.000
0.005	5	None	24999	061A7h	0.000
0.01	10	None	49999	0C34Fh	0.000
0.02	20	/4	24999	061A7h	0.000
0.05	50	/4	62499	0F423h	0.000
0.1	100	/16	31249	07A11h	0.000
0.2	200	/16	62499	0F423h	0.000
0.5	500	/64	39062	09896h	0.000
1.0	1000	/256	19530	04C4Ah	0.001
2.0	2000	/256	39061	09895h	0.001
3.0	3000	/256	58593	0E4E1h	0.001

**Note:** % Error induced by the Timer 1 Formula. This error margin will vary depending on the desired Timer Compare period and the minimum Timer resolution (PS × SYSCLK).

## 7.2.8 Interrupts

### Dual Compare

In dual compare mode, four separate events can generate an interrupt. These interrupts are:

- 1) compare equal from Compare Register 2 if the T1C2 INT ENA bit (T1CTL3.1) is set,
- 2) compare equal from Compare Register 1 if the T1C1 INT ENA bit (T1CTL3.0) is set,
- 3) counter overflow if the T1 OVRFL INT ENA bit (T1CTL2.4) is set, or
- 4) edge detect is set if the T1EDGE INT ENA bit (T1CTL3.2) is set.

### Capture/Compare

In the Capture/Compare mode, three separate events can generate an interrupt. These interrupts are:

- 1) compare equal if the T1C1 INT ENA bit (T1CTL3.0) is set,
- 2) counter overflow if the T1 OVRFL INT ENA bit (T1CTL2.4) is set, and
- 3) input capture acknowledge if the T1EDGE INT ENA (T1CTL3.2) bit is set.

---

#### Note:

All set and enabled interrupt flags must be cleared before exiting the T1 interrupt routine. If the flags are not reset then the processor will enter the T1 interrupt routine again before continuing with the mainstream program. If the flag bits are never reset then the program will lock up.

---

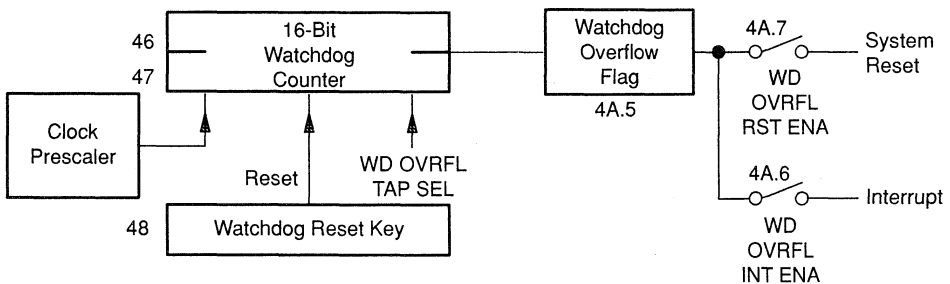


## 7.3 Watchdog Timer

The Watchdog Timer, shown in Figure 7–6, consists of the following blocks:

- ❑ 16-bit, Watchdog/Event Counter which provides up to  $2^{24}$  clock cycles between counter resets depending on the prescaler tap used. The program can read the contents of this counter at locations P046 (MSB) and P047 (LSB) in the peripheral file.
- ❑ Prescaled clock input selection or external clock, the same as the General Purpose Timer.
- ❑ Watchdog Reset key which provides protection against illegal resets.
- ❑ An Overflow flag which the program may read following reset to determine if the Watchdog caused the reset.
- ❑ Programmable interrupt and system reset.

**Figure 7–6. Watchdog Timer**



### 7.3.1 Watchdog Counter

The watchdog timer is a free-running 16-bit resettable up-counter clocked by the output of the Prescaler/Clock source. The timer is software configured as either a watchdog timer to protect against system software failures and corruption, or as a simple counter/timer if the watchdog function is not desired. The 16-bit up-counter is programmable (with the WD OVRFL TAP SEL bit) to set the initial count at either 0000h or 8000h. The current value of the watchdog timer may be read at anytime during its operation (see note in Section 7.5).

#### Watchdog Mode

In the Watchdog mode (WD OVRFL RST ENA = 1), the WD timer generates a system reset which pulls the **RESET** pin low for 8 system clock cycles if the counter overflows or if the WD timer is reinitialized by an incorrect value. The required re-initialization frequency is determined by the system clock

frequency, the prescaler/clock source selected, and whether the WD OVRFL TAP SEL bit is set for 15 or 16 bit counter rollover.

With a 20 MHz clock, the watchdog-timer overflow rates range from 6.55 ms to 3.35 seconds. These values are selected prior to entering the watchdog mode because once the software enables the watchdog reset function (WDOVRFL RST ENA = 1), subsequent writes to these control bits are ignored. Writes to these watchdog control bits can occur only following a power-up reset which enhances watchdog-timer system integrity.

The watchdog timer is re-initialized by writing a predefined value to the watchdog reset key (WDRST) located in the peripheral file at P048. The correct reset key alternates between 55h and AAh, beginning with 55h following the enable of the watchdog reset function. Writes of the correct value must occur prior to the timer overflow period.

A write of any value other than the correct predefined value to the watchdog reset key is interpreted as a lost program and a system reset is initiated. A watchdog-timer overflow or incorrect reset key sets the WD OVRFL INT FLAG bit to 1 and may be interrogated by the program following system reset to determine the source of the reset. This bit must be cleared after a watchdog reset before other watchdog resets can occur.

### **Non-Watchdog Mode**

In the Non-Watchdog mode (WD OVRFL RST ENA = 0), the watchdog timer may be used as an event counter, pulse accumulator, or as an interval timer. In this mode, the system reset function is disabled. The watchdog timer may be re-initialized by writing any value to the watchdog reset key (WDRST). In real-time control applications, the timer overflow rates are determined by the system clock frequency, the prescaler/clock source value selected, and the value of the WD OVRFL TAP SEL bit. If the WD counter is not reset before overflowing, the counter rolls over to either 0000h or 8000h, as determined by the WD OVRFL TAP SEL bit, and continues counting. Upon counter overflow, the WD OVRFL INT FLAG is set and a timer interrupt is generated if the WD OVRFL INT ENA bit set. Alternatively, an external input on the T1EVT pin may be used with the watchdog timer to provide an additional 16-bit event counter or pulse accumulator.

7

### 7.3.2 Power-up Reset

After a system power-up reset, the Watchdog Counter resets to the non-watchdog mode configured as a simple up-counter with the system clock (no prescale) as its input. Thus, if the watchdog mode is used, the program must explicitly enable it (by setting WD OVRFL RST ENA). The Watchdog Counter resets to 0000h when the WD OVRFL RST ENA bit (T1CTL2.7) is set.

#### **Example 7–1. Watchdog Initialization Example**

The following routine initializes the Watchdog Timer to generate a system reset when the counter overflows. The Watchdog counter is set to 16 bits in length and the full 8-bit prescale tap is used.

```

.
.
;Set up Watchdog Timer for a 24-bit countdown time.
;
OR      #70h,P049    ;Set the Watchdog Overflow Tap to 16 bits
                    ;and select the /256 prescale value
OR      #C0h,P04A    ;Watchdog Timer Reset is enabled along
                    ; with clearing and enabling the
                    ; Watchdog Timer interrupt.

```

The Watchdog Timer has now been initialized to cause a system RESET if the counter is not reset before reaching FFFFh. To reset the counter, the code must write an alternating 55h and AAh, starting with 55h, to the Watchdog Timer Reset Key register (P048), e.g.:

```

.
.
MOV     #55h,P048    ;First write to WD RESET KEY
.
.
MOV     #0AAh,P048   ;Next write to WD RESET KEY
.
.
MOV     #55h,P048    ;Next write to WD RESET KEY
.
.

```

### 7.3.3 Reset Frequency

When the Watchdog timer overflows, it pulls the RESET line low to cause a system reset and sets the WD OVRFL INT FLAG bit (T1CTL2.5). The required reset frequency of the watchdog timer is determined by the value of the clock prescaler selected to clock the Watchdog Counter and by the choice of whether the overflow tap is set for a 15 or 16 bit counter. The program must set these choices before entering the watchdog mode.

The overflow tap is selected by the WD OVRFL TAP SEL bit (T1CTL1.7). When WD OVRFL TAP SEL is cleared, the Watchdog Counter is a full 16 bit counter. When WD OVRFL TAP SEL is set, the most-significant bit remains set, the Counter behaves as a 15-bit counter, and overflow occurs twice as often as in the 16-bit configuration.

The watchdog overflow rates are the same as given in Table 7–3 when configured as a 16-bit counter (WD OVRFL TAP SEL = 0). Divide the rates in Table 7–3 in half when the timer is configured as a 15-bit counter (WD OVRFL TAP SEL = 1).

### 7.3.4 Overflow Flag

#### Watchdog Mode

When the Watchdog Counter initiates a reset, it sets the WD OVRFL INT FLAG bit (T1CTL2.5). The program may read this flag after a reset to determine the source of the reset. The program must clear this flag by writing a zero to the WD OVRFL INT FLAG bit.

#### Non-Watchdog Mode

Upon overflow, the module sets the WD OVRFL INT FLAG bit (T1CTL2.5). This causes an interrupt if the WD OVRFL INT ENA bit (T1CTL2.6) is set.

## 7.4 Low-Power Modes

The Timer 1 module supports extended operating states which aid in reducing power consumption during periods of inactivity. These two states are the Halt and the Standby modes. For more information on powerdown modes, see Section 4.1.4.

### 7.4.1 Halt

The halt mode is entered when the CPU executes an IDLE instruction while the Halt/Standby bit (SCCR2.7) and the PWRDWN/IDLE bits (SCCR2.6) are set. During the halt mode, the Timer 1 module holds the pre-halt status of all other storage elements.

The module holds the state of the each external pin constant regardless of whether the pins are used as general purpose port pins or as dedicated I/O pins. That is, inputs remain inputs, output low levels remain low, and output high levels remain high.

When the halt state terminates, the Timer 1 module continues where it left off.

### 7.4.2 Standby

Standby mode is entered by executing an IDLE instruction when the PWRDWN/IDLE (SCCR2.6) bit is set and the HALT/STANDBY bit (SCCR2.7) is cleared. During the standby mode, the watchdog counter clock input is halted while the rest of the Timer 1 module remains fully functional.

## 7.5 Timer 1 Control Registers

Seven registers control the configuration of Timer 1 global functions, prescale values, watchdog timing, optional uses for the associated I/O pins, and other counter functions. The bits shown in shaded boxes in Figure 7–7 are Privilege Mode bits, that is, they can only be written to in the Privilege Mode. The bits shown in the hatched boxes cannot be changed once the WD OVRFL RST ENA bit is set until after a power-up reset.

---

**Note:**

Special circuitry prevents 16-bit registers from changing in the middle of a 16-bit read or write operation. When reading a 16-bit register, read the least-significant byte (LSB) first to lock in the value and then read the most-significant byte (MSB). When writing to a 16-bit register, write the MSB first and then write the LSB. The register value does not change between reading or writing the bytes when done in this order. While accessing a 16-bit register, do not read or write from a second 16-bit register within this module and expect a correct value for the first register's MSB. The 16-bit read/write operation actually occurs when accessing the LSB.

**Read: LSB then MSB**  
**Write: MSB then LSB**

---

Figure 7–7. Peripheral File Frame 4 – Timer 1 Control Registers

ADDR	PF	7	6	5	4	3	2	1	0	
1040h	P040	T1 COUNTER MSB							Bit 8	T1CNTR
1041h	P041	T1 COUNTER LSB							Bit 0	T1CNTR
1042h	P042	COMPARE REGISTER MSB							Bit 8	T1C
1043h	P043	COMPARE REGISTER LSB							Bit 0	T1C
1044h	P044	CAPTURE / COMPARE REGISTER MSB							Bit 8	T1CC
1045h	P045	CAPTURE / COMPARE REGISTER LSB							Bit 0	T1CC
1046h	P046	WATCHDOG COUNTER MSB							Bit 8	WDCNTR
1047h	P047	WATCHDOG COUNTER LSB							Bit 0	WDCNTR
1048h	P048	WATCHDOG RESET KEY							Bit 0	WDRST
1049h	P049	WD OVRFL TAP SEL †	WD INPUT SELECT 2 †	WD INPUT SELECT 1 †	WD INPUT SELECT 0 †	—	T1 INPUT SELECT 2	T1 INPUT SELECT 1	T1 INPUT SELECT 0	T1CTL1
104Ah	P04A	WD OVRFL RST ENA †	WD OVRFL INT ENA	WD OVRFL INT FLAG	T1 OVRFL INT ENA	T1 OVRFL INT FLAG	—	—	T1 SW RESET	T1CTL2
Dual Compare Mode										
104Bh	P04B	T1EDGE INT FLAG	T1C2 INT FLAG	T1C1 INT FLAG	—	—	T1EDGE INT ENA	T1C2 INT ENA	T1C1 INT ENA	T1CTL3
Capture / Compare Mode										
		T1EDGE INT FLAG	—	T1C1 INT FLAG	—	—	T1EDGE INT ENA	—	T1C1 INT ENA	
Dual Compare Mode										
104Ch	P04C	T1 MODE = 0	T1C1 OUT ENA	T1C2 OUT ENA	T1C1 RST ENA	T1CR OUT ENA	T1 EDGE POLARITY	T1CR RST ENA	T1EDGE DET ENA	T1CTL4
Capture / Compare Mode										
		T1 MODE = 1	T1C1 OUT ENA	—	T1C1 RST ENA	—	T1 EDGE POLARITY	—	T1EDGE DET ENA	
104Dh	P04D	—	—	—	—	T1EVT DATA IN	T1EVT DATA OUT	T1EVT FUNCTION	T1EVT DATA DIR	T1PC1
104Eh	P04E	T1PWM DATA IN	T1PWM DATA OUT	T1PWM FUNCTION	T1PWM DATA DIR	T1IC/CR DATA IN	T1IC/CR DATA OUT	T1IC/CR FUNCTION	T1IC/CR DATA DIR	T1PC2
104Fh	P04F	T1 STEST	T1 PRIORITY	—	—	—	—	—	—	T1PRI

† These bits cannot be changed until a power-up reset once the WD OVRFL RST ENA bit is set.

### 7.5.1 Timer 1 Counter Control Register 1

The T1CTL1 Register controls the prescaler inputs to the Watchdog counter and the general purpose counter. The bit assignments and definitions follow:

**Timer 1 Control Register 1 (T1CTL1)**  
[Memory address – 1049h]

BIT#-	7	6	5	4	3	2	1	0
P049	WD OVRFL TAP SEL	WD INPUT SELECT2	WD INPUT SELECT1	WD INPUT SELECT0	—	T1 INPUT SELECT2	T1 INPUT SELECT1	T1 INPUT SELECT0
	RP-0	RP-0	RP-0	RP-0		RW-0	RW-0	RW-0

R=Read, W=Write, P=Write Protected when WD OVRFL RST ENA=1, -n=Value after reset

Bits 0–2 - **T1 INPUT SELECT 0 - 2.** Timer 1 Input Select 0- 2. These three bits select one of eight possible clock sources for the Timer 1 general purpose counter. These sources are:

- the system clock with no prescale (system clock)
- the system clock when the external input T1EVT is high (pulse accumulation)
- an external source synchronized with the system clock (event input)
- no system clock source (no clock input)
- one of four taps from the 8-bit prescaler which provides the system clock divided by either 4, 16, 64, or 256

The combinations are shown below.

2	1	0	Counter Clock Source
0	0	0	system clock
0	0	1	pulse accumulation
0	1	0	event input
0	1	1	no clock input
1	0	0	system clock / 4
1	0	1	system clock / 16
1	1	0	system clock / 64
1	1	1	system clock / 256

Bit 3 - Reserved. Read data is indeterminate.

Bits 4–6 - **WD INPUT SELECT 0 - 2.** Watchdog Input Select 0 - 2. These three bits select one of eight possible clock sources for the Watchdog counter. These sources and the bit combinations to select the sources are the same as listed above for the General Purpose Counter. Once the WD OVRFL RST ENA bit is set, the values of these bits can only be changed after a Power-Up reset.



Bit 7 -

**WD OVRFL TAP SEL.** Watchdog Overflow Tap Select.

This bit determines whether the Watchdog Counter is to operate as a 15 bit or a 16 bit counter. The default is the full 16 bits of the counter. If a shorter Watchdog Counter overflow rate is desired, the most significant bit of the counter can be forced to remain at a 1. This, in effect, changes the Watchdog Counter to a 15-bit counter with an overflow period 1/2 that of a 16 bit counter. This tap select feature, combined with the clock prescaler, allows Watchdog overflow rates from  $2^{15}$  to  $2^{24}$  system clock cycles. This bit is cleared by a) a Power-Up reset, or b) any reset while WD OVRFL RST ENA=0 (Non-Watchdog Mode).

0 = 16-bit Watchdog Counter overflow.

1 = 15-bit Watchdog Counter overflow.

## 7.5.2 Timer 1 Counter Control Register 2

The T1CTL2 register controls the Timer 1 and Watchdog overflow interrupts, and contains the Timer 1 software reset bit. A summary of the bit assignments and definitions is shown below.

**Timer 1 Counter Control Register 2 (T1CTL2)**  
**[Memory Address – 104Ah]**

BIT#-	7	6	5	4	3	2	1	0
P04A	WD OVRFL RST ENA	WD OVERFL INT ENA	WD OVERFL INT FLAG	T1 OVRFL INT ENA	T1 OVRFL INT FLAG	—	—	T1 SW RESET
	RS-0	RW-0	RC-*	RW-0	RC-0			S-0

R=Read, S=Set Only, W=Write, C=Clear Only, -n=Value after reset, \*-see bit description

- Bit 0 - **T1 SW RESET.** Timer 1 Software Reset.  
 This bit is always read as a zero; however, when a one is written to this bit, the counter resets to 0000h on the next system clock cycle.
- Bit 1,2 - Reserved. Read values are indeterminate.
- Bit 3 - **T1 OVRFL INT FLAG.** Timer 1 Overflow Interrupt Flag  
 This bit indicates the status of the T1 Overflow Interrupt.  
 0 = General Purpose Overflow interrupt inactive.  
 1 = General Purpose Overflow interrupt pending.
- Bit 4 - **T1 OVRFL INT ENA.** Timer 1 Overflow Interrupt Enable.  
 This bit controls the Timer 1 Overflow interrupting capability.  
 0 = Disable Interrupt.  
 1 = Enable Interrupt.
- Bit 5 - **WD OVRFL INT FLAG.** Watchdog Overflow Interrupt Flag.  
 This bit indicates the status of the Watchdog overflow interrupt. Clear this bit by writing a zero to it. This bit is NOT cleared following a Watchdog initiated reset. Thus it may be read and cleared, to determine the cause of the reset. This bit is cleared by power-up reset or by any reset if WD OVRFL RST ENA = 0. This bit MUST be cleared after a Watchdog reset before other Watchdog resets can occur.  
 0 = Watchdog Interrupt Inactive  
 1 = Watchdog Counter has overflowed or the incorrect value is written to the Watchdog Reset Key register while in Watchdog mode.
- Bit 6 - **WD OVRFL INT ENA.** Watchdog Overflow Interrupt Enable.  
 This bit controls the Watchdog Overflow interrupting capability. Once the WD OVRFL RST ENA bit is set, the values of these bits can only be changed after a Power-Up reset.  
 0 = Watchdog Interrupt Disabled.  
 1 = Watchdog Interrupt Enabled.

- Bit 7 - **WD OVRFL RST ENA**. Watchdog Overflow Reset Enable.  
This bit controls the ability of a Watchdog overflow to generate a reset. The watchdog counter is a simple up-counter or pulse accumulator when cleared. Once set, this bit can only be cleared by a Power-Up reset, and locks the values of other WD bits so they can only be changed after Power-up reset.
- 0 = Watchdog Counter does *not* initiate a reset upon overflow.
  - 1 = Watchdog Counter *does* initiate a reset upon overflow.

**Note:**

Be careful using the AND, OR, XOR, CMPBIT, SBIT0 or SBIT1 instruction to modify this register. The Read/Modify/Write nature of these instructions may inadvertently clear an interrupt flag that was set between the read and the write cycles. If the state of the interrupt enable bits is known, the MOV #n1,Pn2 instruction can be used. If the state of the interrupt enable bits is not known, a sequence similar to the example shown below should be used.

```
;clearing the T1 OVRFL INT FLAG
MOV    P04A,A
OR     #028h,A
AND    #0F7h,A
MOV    A,P04A
```

### 7.5.3 Timer 1 Counter Control Register 3

The T1CTL3 register controls the edge-detect and compare interrupts. The six active bits in this register serve different functions for each mode, as shown below:

**Timer 1 Control Register 3 (T1CTL3)**  
**[Memory Address – 104Bh]**

**Mode: Dual Compare**

BIT#-	7	6	5	4	3	2	1	0
P04B	T1EDGE INT FLAG	T1C2 INT FLAG	T1C1 INT FLAG	—	—	T1EDGE INT ENA	T1C2 INT ENA	T1C1 INT ENA
	RC-0	RC-0	RC-0			RW-0	RW-0	RW-0

**Mode: Capture/Compare**

BIT#-	7	6	5	4	3	2	1	0
P04B	T1EDGE INT FLAG	—	T1C1 INT FLAG	—	—	T1EDGE INT ENA	—	T1C1 INT ENA
	RC-0		RC-0			RW-0		RW-0

7

R=Read, W=Write, C=Clear Only, -n=Value after reset

- Bit 0 - **T1C1 INT ENA.** Timer 1 Compare 1 Interrupt Enable.  
 This bit determines whether or not the compare register flag can generate an interrupt.  
 0 = Disable interrupt.  
 1 = Enable interrupt.
- Bit 1 - **T1C2 INT ENA.** Timer 1 Compare 2 Interrupt Enable.  
*Dual Compare mode only:* This bit determines whether or not the Capture/Compare register flag can generate an interrupt.  
 0 = Disable interrupt.  
 1 = Enable interrupt.  
  
*Capture/Compare Mode:*  
 Reserved. Read data is indeterminate.
- Bit 2 - **T1EDGE INT ENA.** Timer 1 Edge Interrupt Enable.  
 This bit determines whether or not the active edge input to the T1IC/CR pin generates an interrupt. The T1EDGE DET ENA bit (T1CTL4.0) must be set before an edge can be detected.  
 0 = Disable interrupt.  
 1 = Enable interrupt.
- Bits 3,4 - Reserved. Read data is indeterminate.

- Bit 5 - **T1C1 INT FLAG.** Timer 1 Compare 1 Interrupt Flag.  
 This bit is set when the compare register first matches the counter value.  
 0 = Interrupt inactive.  
 1 = Interrupt pending.
- Bit 6 - **T1C2 INT FLAG.** Timer 1 Compare 2 Interrupt Flag.  
*Dual Compare Mode:* This bit is set when the Capture/Compare register first matches the counter value.  
 0 = Interrupt inactive.  
 1 = Interrupt pending.
- Capture/Compare Mode:*  
 Reserved. Read data is indeterminate.
- Bit 7 - **T1EDGE INT FLAG.** Timer 1 Edge Interrupt Flag.  
 This bit indicates when an external pulse transition of the correct polarity is detected on the Timer 1 Input-Capture/Counter-Reset (T1IC/CR) pin. This bit also indicates an input capture in the Capture/Compare mode.  
 0 = no transition  
 1 = transition detected

**Note:**

Be careful using the AND, OR, XOR, CMPBIT, SBIT0 or SBIT1 instruction to modify this register. The Read/Modify/Write nature of these instructions may inadvertently clear an interrupt flag that was set between the read and the write cycles. If the state of the interrupt enable bits is known, the MOV #n1,Pn2 instruction can be used. If the state of the interrupt enable bits is not known, a sequence similar to the example shown below should be used.

```

;Clearing the T1C1 INT FLAG
MOV    P04B,A
OR     #0E0h,A
AND    #0DFh,A
MOV    A,P04B
    
```

### 7.5.4 Timer 1 Counter Control Register 4

The T1CTL4 register controls the mode of operation, and various functions of the Timer 1 input and output pins. The bits in this register serve different functions depending on the mode, as shown below:

**Timer 1 Counter Control Register 4 (T1CTL4)**  
[Memory Address – 104Ch]

**Mode: Dual Compare**

BIT#-	7	6	5	4	3	2	1	0
P04C	T1 MODE =0	T1C1 OUT ENA	T1C2 OUT ENA	T1C1 RST ENA	T1CR OUT ENA	T1 EDGE POLAR- ITY	T1CR RST ENA	T1EDGE DET ENA
	RW-0	RW-0	RW-0	RW-0	RW-0	RW-0	RW-0	RW-0

**Mode: Capture/Compare**

BIT#-	7	6	5	4	3	2	1	0
P04C	T1 MODE =1	T1C1 OUT ENA	—	T1C1 RST ENA	—	T1 EDGE POLAR- ITY	—	T1EDGE DET ENA
	RW-0	RW-0		RW-0		RW-0		RW-0

R– Read, W– Write, –n = Value after reset

The function of the bits are as follows.

Bit 0 - **T1EDGE DET ENA.** Timer 1 Edge Detect Enable.

*Dual Compare Mode:* This bit enables the edge detection circuit to sense the next level transition on the Timer 1 T1IC/CR pin. This bit is cleared after the selected transition is detected or during reset.

- 0 = Edge detect disabled
- 1 = Edge detect enabled.

*Capture/Compare Mode:* This bit enables the input capture circuit to capture the current counter value upon the next level transition on the counter reset/input capture pin, as determined by the T1EDGE POLARITY bit. This bit remains unchanged after the selected transition is detected.

- 0 = Input capture disabled.
- 1 = Input capture enabled.

- Bit 1 - **T1CR RST ENA.** Timer 1 External Reset Enable.  
*Dual Compare Mode:* This bit determines whether or not an external signal can reset the counter.  
 0 = Disable external reset of the counter.  
 1 = Enable external reset of the counter on the next valid edge detect.  
  
*Capture/Compare Mode:*  
 Reserved. Read data is indeterminate.
- Bit 2 - **T1EDGE POLARITY.** Timer 1 Edge Polarity.  
 This bit determines the transition direction on the Timer 1 T1IC/CR pin to trigger a capture or counter reset, depending on the counter mode selected.  
 0 = Trigger on a high-to-low transition.  
 1 = Trigger on a low-to-high transition.
- Bit 3 - **T1CR OUT ENA.** Timer 1 External Edge Output Enable.  
*Dual Compare Mode:* This bit determines whether or not the input signal on the T1IC/CR pin can toggle the output signal on the T1PWM pin.  
 0 = Disable pulse to toggle output.  
 1 = Enable pulse to toggle output.  
  
*Capture/Compare Mode:*  
 Reserved. Read data is indeterminate.
- Bit 4 - **T1C1 RST ENA.** Timer 1 Compare 1 Reset Enable.  
 When this bit is set and Compare Register 1 is equal to the Counter, the Counter will reset on the next counter increment.  
 0 = Disable counter reset upon compare equal.  
 1 = Enable counter reset upon compare equal.
- Bit 5 - **T1C2 OUT ENA.** Timer 1 Output-Compare Output Enable 2.  
*Dual Compare Mode:* When this bit is set and Compare Register 2 is equal to the Counter, the T1PWM pin toggles (when configured as a PWM pin).  
 0 = Disable pulse to toggle output.  
 1 = Enable pulse to toggle output.  
  
*Capture/Compare Mode:*  
 Reserved. Read data is indeterminate.
- Bit 6 - **T1C1 OUT ENA.** Timer 1 Output-Compare Output Enable 1.  
 When this bit is set and the Compare Register 1 is equal to the Counter, the T1PWM pin toggles (when configured as a PWM pin).  
 0 = Disable pulse to toggle output.  
 1 = Enable pulse to toggle output.
- Bit 7 - **T1 MODE.** Timer 1 Mode Select.  
 This bit selects the General Purpose Counter mode.  
 0 = Dual compare mode  
 1 = Capture/Compare mode.

## 7.5.5 Timer 1 Port Control Registers

Port Control Registers T1PC1 and T1PC2 are organized to allow all functions for a pin to be programmed in one write cycle. Each module pin is controlled by a nibble in one of the PCRs. A summary of the Port Control Register functions and bit assignments is shown below.

### 7.5.5.1 Timer 1 Port Control Register 1

The T1PC1 register controls the I/O functions of the Timer 1 Module, T1EVT pin.

**Timer 1 Port Control Register 1 (T1PC1)**  
[Memory Address – 104Dh]

BIT#-	7	6	5	4	3	2	1	0
P04D	—	—	—	—	T1EVT DATA IN	T1EVT DATA OUT	T1EVT FUNC- TION	T1EVT DATA DIR
					R-0	RW-0	RW-0	RW-0

R=Read, W=Write, -n=Value after reset

- Bit 0 - **T1EVT DATA DIR.** Timer 1 Event-Pin Data Direction.  
This bit selects the T1EVT pin as an input or output, if the T1EVT FUNCTION bit = 0.  
0 = Enable T1EVT pin as data input.  
1 = Enable T1EVT pin as data output.
- Bit 1 - **T1EVT FUNCTION.** T1EVT Pin Function Select.  
This bit determines the function of the T1EVT pin.  
0 = T1EVT is a general-purpose digital I/O pin.  
1 = T1EVT is the event-input pin.
- Bit 2 - **T1EVT DATA OUT.** T1EVT Pin Data Out.  
This bit contains the data to be output on the T1EVT pin if the following conditions are met:  
a. T1EVT DATA DIR = 1.  
b. T1EVT FUNCTION = 0.
- Bit 3 - **T1EVT DATA IN.** T1EVT Pin Data In.  
This bit contains the data present on the T1EVT pin. A write operation to this bit has no effect.
- Bits 4–7 - Reserved. Read data is indeterminate.



### 7.5.5.2 Timer 1 Port Control Register 2

The T1PC2 register controls the I/O functions of the Timer 1 Module, T1IC/CR and T1PWM pins.

**Timer 1 Port Control Register 2 (T1PC2)**  
**[Memory Address – 104Eh]**

BIT#-	7	6	5	4	3	2	1	0
P04E	T1PWM DATA IN	T1PWM DATA OUT	T1PWM FUNC- TION	T1PWM DATA DIR	T1IC/CR DATA IN	T1IC/CR DATA OUT	T1IC/CR FUNC- TION	T1IC/CR DATA DIR
	R-0	RW-0	RW-0	RW-0	R-0	RW-0	RW-0	RW-0

R=Read, W=Write, -n= Value after reset

- Bit 0 - **T1IC/CR DATA DIR.** T1IC/CR Pin Data Direction.  
 This bit selects the T1IC/CR pin as an input or output, if the T1IC/CR Function bit = 0.  
 0 = Enable T1IC/CR pin data input.  
 1 = Enable T1IC/CR pin data output.
- Bit 1 - **T1IC/CR FUNCTION.** T1IC/CR Pin Function Select.  
 This bit determines the function of the T1IC/CR pin.  
 0 = the T1IC/CR pin is a general-purpose digital I/O pin.  
 1 = the T1IC/CR pin is the input capture/counter reset pin.
- Bit 2 - **T1IC/CR DATA OUT.** T1IC/CR Pin Data Out.  
 This bit contains the data output on pin T1IC/CR if the following conditions are met:  
 a. T1IC/CR DATA DIR = 1.  
 b. T1IC/CR FUNCTION = 0.
- Bit 3 - **T1IC/CR DATA IN.** T1IC/CR Pin Data In.  
 This pin contains the data input on pin T1IC/CR. A write operation to this bit has no effect.
- Bit 4 - **T1PWM DATA DIR.** T1PWM Pin Data Direction.  
 This bit selects the T1PWM pin as an input or output if the T1PWM FUNCTION bit = 0.  
 0 = Enable T1PWM pin data input.  
 1 = Enable T1PWM pin data output.
- Bit 5 - **T1PWM FUNCTION.** T1PWM Pin Function Select.  
 This bit determines the function of the T1PWM pin.  
 0 = the T1PWM pin is a general-purpose digital I/O pin.  
 1 = the T1PWM pin is the PWM output.

- Bit 6 - **T1PWM DATA OUT.** T1PWM Pin Data Out.  
This bit contains the data to be output on the T1PWM pin if the following conditions are met:
- a. T1PWM DATA DIR = 1
  - b. T1PWM FUNCTION = 0
- This bit may be used to preset the PWM output level.
- Bit 7 - **T1PWM DATA IN.** T1PWM Pin Data In 1.  
This bit contains the data input on pin T1PWM. A write operation to this bit has no effect.

**Note:**

See Section 14.6.1 for examples of PWM pin initialization.

### 7.5.6 Timer 1 Interrupt Priority Control Register

The T1PRI register controls the level of the Timer 1 interrupt. Software can write to this register only in the privilege mode. During normal operation this is a read-only register.

**Timer 1 Interrupt Priority Control Register (T1PRI)**  
**[Memory Address – 104Fh]**

BIT#-	7	6	5	4	3	2	1	0
P04F	T1 STEST	T1 PRIOR- ITY	—	—	—	—	—	—
	RP-0	RP-0						

R=Read, P=Privileged Write, -n=Value after reset

Bits 0–5 - Reserved. Read data is indeterminate.

Bit 6 - **T1 PRIORITY.** Timer 1 Interrupt Priority Select.  
 This bit determines the level of the interrupt generated by Timer 1.

0 = Interrupts are Level 1 (high priority) requests.

1 = Interrupts are Level 2 (low priority) requests.

Bit 7 - **T1 STEST.** This bit must be cleared (0) to ensure proper operation.



Introduction	1
Assembly Language Instruction Set	13
TMS370 Family Devices	2
Design Aids	14
CPU and Memory Organization	3
Development Support	15
System and Digital I/O Configuration	4
Electrical Specifications	16
Interrupts and System Reset	5
Customer Information	17
EEPROM Modules	6
Appendices	A-H
Timer 1 Module	7
Timer 2 Module	8
Serial Communications Interface (SCI) Port	9
Serial Peripheral Interface (SPI) Module	10
Analog-to-Digital Converter Module	11
TMS370 Programmable Acquisition and Control Timer	12



## Timer 2 Module

---

---

---

---

This chapter discusses the architecture and programming of the Timer 2 module of the TMS370 family and covers the following topics:

<b>Section</b>	<b>Page</b>
8.1 Timer 2 Overview .....	8-2
8.2 Timer 2 Operation .....	8-5
8.3 Timer 2 Control Registers .....	8-16

## 8.1 Timer 2 Overview

The Timer 2 module (T2) adds an additional timer that provides event count, input capture, and compare functions. Figure 8–1 shows a block diagram of the Timer 2 Module.

System Requirements	Timer Resource
Real-Time System Control	Interval Timers with Interrupts
Input Pulse Width Measurement	Pulse Accumulate or Input Capture Functions
External Event Synchronization	Event Count Function
Timer Output Control	Compare Function
Pulse-Width Modulated Output	PWM Output Function Control

The Timer 2 Module has three I/O pins which may be reconfigured as general purpose I/O Pins for use by other parts of the microcomputer. They are:

- ❑ T2EVT
- ❑ T2IC1/CR
- ❑ T2IC2/PWM

When these pins are dedicated to the timer module, T2EVT is an input to the event counter or the external clock source, T2IC1/CR is an input to the counter reset, input capture, or PWM circuit, and T2IC2/PWM is the Pulse Width Modulation output or a second input capture.

The Timer 2 Module consists of the following blocks as shown in Figure 8–1:

- ❑ 16-bit resettable up counter,
- ❑ 16-bit Compare Register with associated compare logic,
- ❑ 16-bit Capture Register,
- ❑ 16-bit Capture/Compare Register.

The General Purpose Counter operates in one of two modes. The mode of operation determines whether the Capture/Compare Register functions as a compare register (in the Dual Compare mode) or as a capture register (the Dual Capture mode).

Timer 2 has maskable interrupts for two input captures, two output compares, counter overflow and external edge detect.





*Dual Capture Mode:* The counter is configured to provide dual input capture registers and one compare register for use as a general purpose timer. The Compare Register may be used to provide periodic interrupts to the rest of the microcomputer. Each capture register may be configured to capture the current counter value upon either edge of an external input.

**Timer 2 Control Registers**

The Timer 2 Control registers are located at addresses 1060h to 106Fh, with locations 1068h and 1069h reserved. The functions of these locations are shown in Table 8–1.

**Table 8–1. Timer 2 Memory Map**

Peripheral File Location	Symbol	Name
P060	T2CNTR	T2 Counter – MSB
P061		T2 Counter – LSB
P062	T2C	T2 Compare 1 Register – MSB
P063		T2 Compare 1 Register – LSB
P064	T2CC	T2 Capture 1/Compare Register 2 – MSB
P065		T2 Capture 1/Compare Register 2 – LSB
P066	T2IC	Capture Register 2 – MSB
P067		Capture Register 2 – LSB
P068		Reserved
P069		Reserved
P06A	T2CTL1	Timer 2 Control Register 1
P06B	T2CTL2	Timer 2 Control Register 2
P06C	T2CTL3	Timer 2 Control Register 3
P06D	T2PC1	Timer 2 Pin Control 1
P06E	T2PC2	Timer 2 Pin Control 2
P06F	T2PRI	Timer 2 Priority

## 8.2 Timer 2 Operation

The 16-bit general purpose timer, T2, is composed of a 16-bit resettable counter, 16-bit Compare Register with associated compare logic, a 16-bit Capture Register, and a 16-bit register that functions as a capture register in one mode and a compare register in the other mode. In the following paragraphs, the functions of each block within T2 is discussed in general and for each mode of operation.

### 8.2.1 Operation Modes

The Timer 2 module mode of operation is determined by the T2 MODE bit (T2CTL3.7).

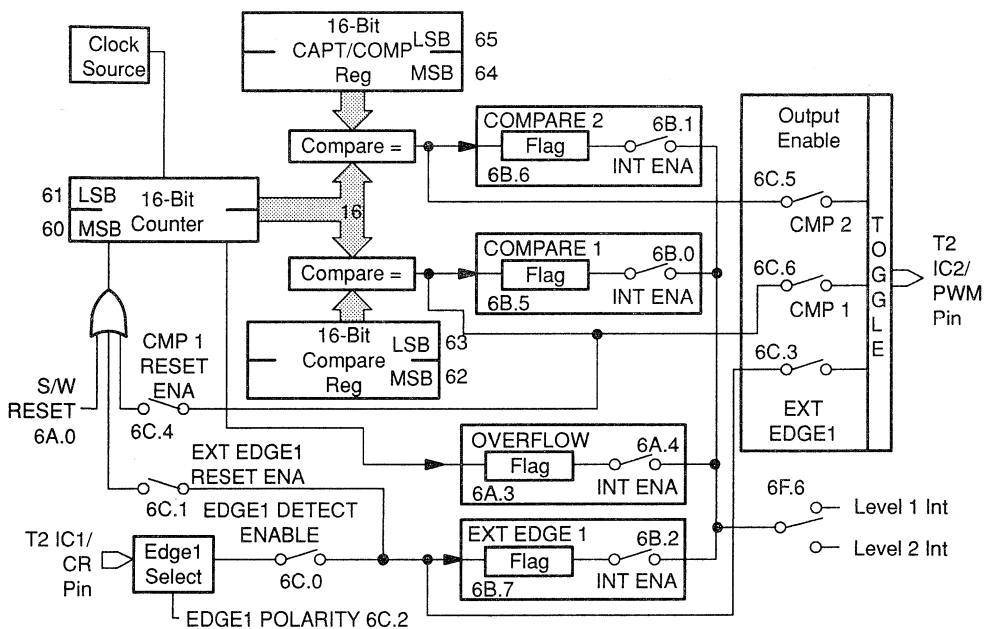
T2 MODE = 0 – Dual Compare Mode.

T2 MODE = 1 – Dual Capture Mode.

### Dual Compare Mode

In this mode, as illustrated in Figure 8–2, the timer has two compare registers, an external-resettable counter, and a timer output pin. These allow the timer to act as an interval timer, a PWM output, simple output toggle, or many other timer functions. In this mode, the Capture/Compare Register functions as a 16-bit read/write compare register. The operation of T2 is identical to T1 while operating in the Dual Compare mode with the exception of the clock sources.

Figure 8–2. Dual Compare Mode



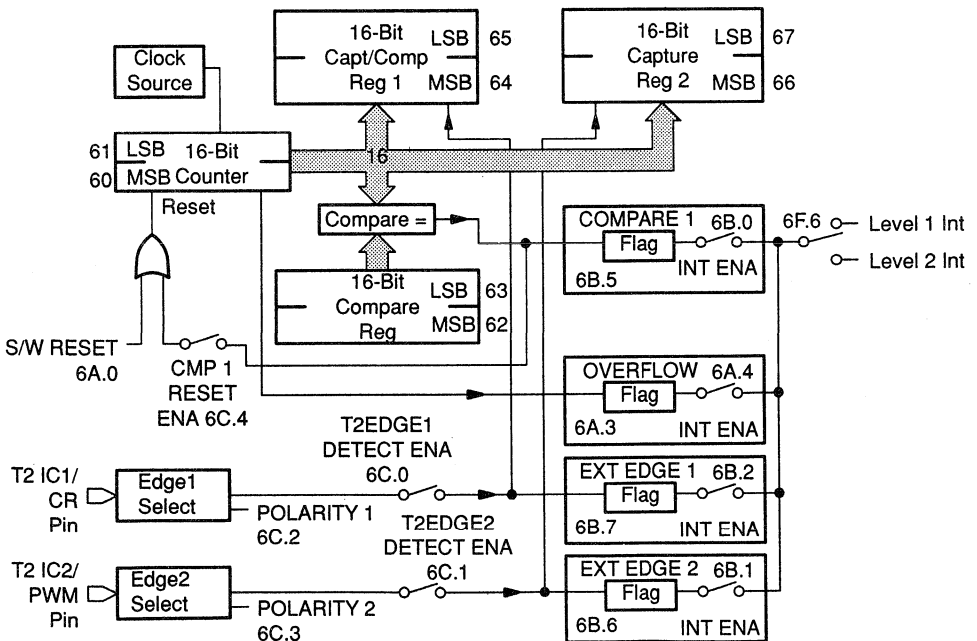
8

### Dual Capture Mode

In the Dual Capture Mode, illustrated in Figure 8–3, T2 is configured to provide one compare register for use as a programmable interval timer, and two input capture registers for external input timing and pulse width measurement. In this mode the Capture/Compare Register functions as 16-bit input capture register. Each capture input pin (T2IC1/CR and T2IC2/PWM) has an input edge detect function enabled by the associated DET ENA control bit, with the associated POLARITY bit selecting the active input transition.

On the occurrence of a valid input on the T2IC1/CR or T2IC2/PWM pin, the current counter value is loaded into the 16-bit Capture/Compare Register or 16-bit input Capture Register, respectively. In addition, the respective input capture INT FLAG is set and a timer interrupt is generated if the respective INT ENA is set.

Figure 8–3. Dual Capture Mode



## 8.2.2 Clock Sources

Timer 2 clock sources are illustrated in Figure 8–4. The T2 INPUT SELECT 0 bit (T2CTL1.1) and the T2 INPUT SELECT 1 bit (T2CTL1.2) select one of four clock sources:

- System clock
- No clock (the counter is stopped)
- External clock synchronized to the system clock (event counter) or
- System clock when external input is high (pulse accumulation)

The maximum counter duration with an internal clock is based on the internal system clock time (SYSCLK) as follows:

$$\begin{aligned} \text{Maximum Counter Duration} &= 2^{16} \times \text{SYSCLK} \\ \text{Counter Resolution} &= \text{SYSCLK} \end{aligned}$$

$$\text{where; SYSCLK} = 4/\text{CLKIN}$$

The external event frequency input to the module may not exceed CLKIN/8. All external event inputs are synchronized with the system clock.

When using the system clock input, the 16-bit timer generates an overflow rate of 13.1 ms with 200 ns resolution (CLKIN = 20 MHz).

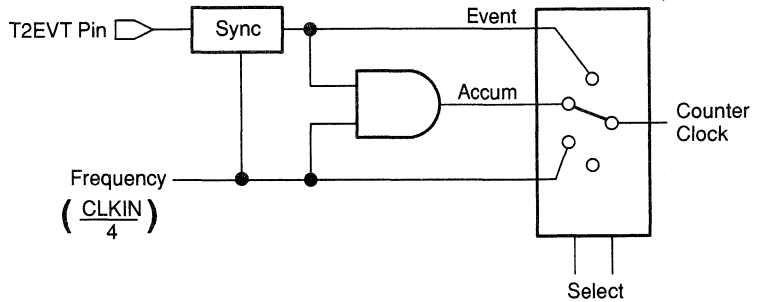
### Event Counter Mode

Using this clock source, the general purpose timer is programmable as a 16-bit event counter. An external low-to-high transition on the T2EVT pin is used to provide the clock for the internal timer. The T2EVT external clock frequency may not exceed the system clock frequency divided by 2.

### Pulse Accumulator Mode

Using this clock source, the general purpose timer is programmable as a 16-bit pulse accumulator. An external input on the T2EVT pin is used to gate the internal system clock to the internal timers. While T2EVT input is logic one (high), the timer is clocked at the system clock rate and counts system clock pulses until the T2EVT pin returns to logic zero.

Figure 8–4. Timer 2 Clock Sources



### 8.2.3 Timer 2 Edge Detection Circuitry

This edge detection circuitry senses an active pulse transition on the input pins and provides appropriate output transitions to the rest of the module.

#### Dual Compare Mode

The edge detection circuitry is connected to the module's T2IC1/CR pin. In this mode, the program must re-enable the Timer 2 Module after each edge detection by setting the T2EDGE1 DET ENA bit (T2CTL3.0).

When the Timer 2 module detects an active transition (while enabled), the module performs the following actions:

- 1) clears the T2EDGE DET ENA bit,
- 2) sets the external edge flag, T2EDGE1 INT FLAG (T2CTL2.7),
- 3) resets the counter if T2EDGE1 RST ENA bit (T2CTL3.1) is set, and
- 4) toggles the output flip-flop if the T2EDGE1 OUT ENA bit (T2CTL3.3) is set.

In the Dual Compare mode, the T2EDGE1 POLARITY bit (T2CTL3.2) determines whether the active transition is low-to-high or high-to-low.

### Dual Capture Mode

Edge detection circuitry is connected to both the T2IC1/CR pin and the T2IC2/PWM pin.

When the Edge 1 Detect circuit detects an active edge transition on the T2IC1/CR pin:

- 1) the Capture/Compare Register is loaded with the current counter value, and
- 2) the T2EDGE1 INT FLAG bit is set.

When the Edge 2 Detect circuit detects an active edge transition on the T2IC2/PWM pin:

- 1) the Capture Register is loaded with the current counter value, and
- 2) the T2EDGE2 INT FLAG bit is set.

The T2EDGE1 POLARITY bit (T2CTL3.2) and the T2EDGE2 POLARITY bit (T2CTL3.3) determine the transition (rising or falling) to be detected.

## 8.2.4 16-Bit Resettable Up Counter

The counter is a free-running, 16-bit, read-only, up-counter clocked by the system clock, external event, or system clock while an external event is active (pulse accumulate). During initialization, the counter is loaded with 0000h and begins its up-count. If the counter is not reset before reaching FFFFh, the counter rolls over to 0000h and continues counting. Upon counter roll-over, the T2 OVRFL INT FLAG (T2CTL1.3) is set, and a timer interrupt is generated if the T2OVRFL INT ENA bit (T2CTL1.4) is set.

The counter may be reset to 0000h during counting by either:

- 1) writing a 1 to the T2 SW RESET bit (T2CTL1.0),
- 2) a compare equal condition from the dedicated T2 compare function,
- 3) System  $\overline{\text{RESET}}$ , or
- 4) an external pulse on the T2IC/CR pin (Dual Compare mode only).

The designer may select by software (T2CR POLARITY bit) which external transition, low-to-high or high-to-low, on the T2IC1/CR pin will cause the counter to be reset.

Special circuitry prevents the contents of the T2CNTR register from changing in the middle of a 16-bit read operation. See note in Section 8.3.



### 8.2.5 Compare Register

The Compare Register circuit consists of a 16-bit wide, read/write data register (T2C) and logic to compare the counter's current value with the value stored in the Compare Register.

Special circuitry prevents the T2C register from changing in the middle of a 16-bit read or write operation. See note in Section 8.3.

The compare logic sets T2C1 INT FLAG (T2CTL2.5) as soon as the value in the timer matches that in the Compare Register. Once T2C1 INT FLAG is set by a compare-equal condition, then cleared, it will not be set again if the same compare-equal condition still exists, i.e., the same compare-equal condition can only set the T2C1 INT FLAG once. This flag causes various events to occur depending on the mode of operation and which enable bits are set.

In a compare equal condition, the T2 module:

- 1) sets the T2C1 INT FLAG bit (T2CTL2.5),
- 2) generates an interrupt if the T2C1 INT ENA bit (T2CTL2.0) is set, and
- 3) resets the counter if T2C1 RST ENA bit (T2CTL3.4) is set.

In Dual Compare Mode only:

- 4) toggles the PWM output pin if the T2C1 OUT ENA bit (T2CTL3.6) is set.

### 8.2.6 Capture Register (Dual Capture Mode Only)

The Capture Register is a 16-bit wide, read-only, data register (T2IC). This register captures the counter values when an input capture pulse (pin T2IC2/PWM) is received. The Capture Register can be read at addresses P066 (MSB) and P067 (LSB) of the peripheral file. Writes to this register are ignored. Thus, the Capture Register retains the last counter value captured until another input capture pulse loads a new value in the register.

On receipt of a capture pulse, the following events occur:

- 1) value of counter is loaded into the Capture Register,
- 2) the module sets the T2EDGE2 INT FLAG bit (T2CTL2.6) to indicate that the Capture Register has latched the current counter value, and
- 3) the module generates an interrupt if the T2C2 INT ENA bit (T2CTL2.1) is set.

Special circuitry prevents the T2IC register from changing in the middle of a 16-bit read or write operation. See note in Section 8.3.

## 8.2.7 Capture/Compare Register

The Capture/Compare Register (T2CC) for Timer 2 is a 16-bit wide register which can be programmed to serve one of two functions. In the Dual Capture Mode this register functions as a capture register and in the Dual Compare Registers Mode, it functions as a compare register. The Capture/Compare Register is located at addresses P064 (MSB) and P065 (LSB) of the peripheral file.

Special circuitry prevents the T2CC register from changing in the middle of a 16-bit read or write operation. See note in Section 8.3.

**Dual Compare Mode:** In the Dual Compare mode, the Capture/Compare Register becomes a read/write compare register. This compare register's functions are similar to the dedicated Compare Register except that it can **not** reset the counter.

In this mode, the current counter value and the current Capture/Compare register value are directed to compare logic which generates a pulse when the two values match. This pulse is used to:

- 1) set the T2C2 INT FLAG bit (T2CTL2.6),
- 2) toggle the PWM output pin if the T2C2 OUT ENA bit (T2CTL3.5) is set, and
- 3) generate an interrupt if the T2C2 INT ENA bit (T2CTL2.1) is set.

**Dual Capture Mode:** In the Dual Capture Mode, the Capture/Compare Register becomes a read-only capture register. When an external pulse appears on pin T2IC1/CR, the following events occur if the T2EDGE1 DET ENA bit (T2CTL3.0) is set.

- 1) the current counter value is latched into the Capture/Compare register.
- 2) the T2EDGE1 INT FLAG bit (T2CTL2.7) is set.
- 3) an interrupt is generated if the T2EDGE1 INT ENA bit (T2CTL2.2) is set.

## 8.2.8 Timer 2: Compare Register Formula

The Compare Register value required for a specific timing application can be calculated using the following formula:

$$\text{Compare Value} = \frac{t}{\text{SYSCLK}} - 1$$

where:

$$t = \text{desired timer Compare period (seconds)}$$

$$\text{SYSCLK} = 4 / \text{CLKIN (external clock frequency)}$$

Table 8–2 provides some sample Compare Register values to achieve various desired timings.

**Table 8–2. Timer 2 Compare Values: (CLKIN = 20 MHz)**

Time		T2 Compare Register		% Error (See Note)
Seconds	mSeconds	Decimal	Hex	
0.0005	0.5	2499	009C3h	0.000
0.001	1	4999	01387h	0.000
0.002	2	9999	0270Fh	0.000
0.005	5	24999	061A7h	0.000
0.010	10	49999	0C34Fh	0.000
0.013	13	64999	0FDE7h	0.000

**Note:** % Error induced by the Timer 2 Formula. This error margin will vary depending on the desired Timer Compare period and the minimum Timer resolution (SYSCLK).

8

## 8.2.9 Timer 2 I/O Pin Functions

The Timer 2 module has three I/O pins which may be dedicated as timer functions or used as general purpose I/O pins. The definitions of these pins are contained in the two Port Control Registers located at addresses P06E and P06D of the peripheral file.

Table 8–3 defines the functions of the three Timer 2 I/O pins for both operating modes.

**Table 8–3. Timer 2 I/O Pin Definitions**

Pin	Dual Compare Mode	Dual Capture Mode
T2IC1/CR	Counter Reset Input	Input Capture 1 Input
T2IC2/PWM	PWM Output	Input Capture 2 Input
T2EVT	External Event Input or Pulse Accumulate Input	External Event Input or Pulse Accumulate Input

## 8.2.10 Timer 2 Interrupts

Interrupts may be enabled to occur upon an input capture, output compare equal, counter overflow and/or upon an external edge detect.

*Dual Compare Mode:* In this mode, interrupts are generated when any of the following events occur:

- 1) when a compare equal condition occurs for the dedicated Compare Register if the T2C1 INT ENA bit (T2CTL2.0) is set,
- 2) when a compare equal condition occurs for the Capture/Compare Register if the T2CC2 INT ENA bit (T2CTL2.1) is set,
- 3) when the counter overflows if the T2 OVERFL INT ENA bit (T2CTL1.4) is set, or
- 4) when an External Edge detect occurs if the T2EDGE1 DET ENA and T2EDGE1 INT ENA bits are set (T2CTL3.0 and T2CTL2.2 respectively).

*Dual Capture Mode:* In this mode, interrupts are generated when any of the following events occur:

- 1) when a compare equal condition occurs for the dedicated Compare Register if the T2C1 INT ENA bit (T2CTL2.0) is set,
- 2) when the counter overflows if the T2 OVERFL INT ENA bit (T2CTL1.4) is set,
- 3) when an External Edge 1 detect occurs if the T2EDGE1 DET ENA and T2EDGE1 INT ENA bits are set (T2CTL3.0 and T2CTL2.2), or
- 4) when an External Edge 2 detect occurs if the T2EDGE2 DET ENA and T2EDGE2 INT ENA bits are set (T2CTL3.1 and T2CTL2.1).

8

---

**Note:**

All set and enabled interrupt flags must be cleared before exiting the T2 interrupt routine. If the flags are not reset, then the processor will enter the T2 interrupt routine again instead of continuing the mainstream program. If the flag bits are never cleared then the program will lock up.

---

### 8.2.11 Power-Down Modes

This module supports the power-down modes which aid in reducing power consumption during periods of inactivity. In both the Halt and Standby modes, no clocks or external inputs are recognized.

The low-power modes are entered when an IDLE instruction is executed by the CPU if the POWERDOWN/IDLE bit (SCCR2.6) is set. During the low-power mode, the Timer 2 Module holds the pre-idle status of all storage elements. The module's external pins are held constant regardless of the pin function, i.e., inputs remain inputs, output low levels remain low, and output high levels remain high. When the idle state is exited, the I/O Timer module continues from where it left off.

### 8.3 Timer 2 Control Registers

Peripheral file registers control the Timer 2 module operating mode selection, interrupt enable, status flags, and output configuration. These registers are shown in Table 8–4. The bits shown in shaded boxes in Table 8–4 are Privilege Mode bits, that is, they can only be written to in the Privilege Mode.

---

**Note:**

Special circuitry prevents 16-bit registers from changing in the middle of a 16-bit read or write operation. When reading a 16-bit register, read the least-significant byte (LSB) first to lock in the value and then read the most-significant byte (MSB). When writing to a 16-bit register, write the MSB first and then write the LSB. The register value does not change between reading or writing the bytes when done in this order. While accessing a 16-bit register, do not read or write from a second 16-bit register within this module and expect a correct value for the first register's MSB. The 16-bit read/write operation actually occurs when accessing the LSB.

**Read: LSB then MSB**

**Write: MSB then LSB**

---

**Table 8–4. Peripheral File Frame 6: Timer 2 Control Registers**

ADDR	PF	7	6	5	4	3	2	1	0	
1060h	P060	Bit 15	T2 COUNTER MSB						Bit 8	T2CNTR MSB
1061h	P061	Bit 7	T2 COUNTER LSB						Bit 0	T2CNTR LSB
1062h	P062	Bit 15	COMPARE REGISTER MSB						Bit 8	T2C MSB
1063h	P063	Bit 7	COMPARE REGISTER LSB						Bit 0	T2C LSB
1064h	P064	Bit 15	CAPTURE/COMPARE REGISTER MSB						Bit 8	T2CC MSB
1065h	P065	Bit 7	CAPTURE/COMPARE REGISTER LSB						Bit 0	T2CC LSB
1066h	P066	Bit 15	CAPTURE REGISTER 2 MSB						Bit 8	T2IC MSB
1067h	P067	Bit 7	CAPTURE REGISTER 2 LSB						Bit 0	T2IC LSB
106Ah	P06A	—	—	—	T2 OVRFL INT ENA	T2 OVRFL INT FLAG	T2 INPUT SELECT1	T2 INPUT SELECT0	T2 SW RESET	T2CTL1
Dual Compare Mode										
106Bh	P06B	T2EDGE1 INT FLAG	T2C2 INT FLAG	T2C1 INT FLAG	—	—	T2EDGE1 INT ENA	T2C2 INT ENA	T2C1 INT ENA	T2CTL2
Dual Capture Mode										
		T2EDGE1 INT FLAG	T2EDGE2 INT FLAG	T2C1 INT FLAG	—	—	T2EDGE1 INT ENA	T2EDGE2 INT ENA	T2C1 INT ENA	
Dual Compare Mode										
106Ch	P06C	T2 MODE = 0	T2C1 OUT ENA	T2C2 OUT ENA	T2C1 RST ENA	T2EDGE1 OUT ENA	T2EDGE1 POLARITY	T2EDGE1 RST ENA	T2EDGE1 DET ENA	T2CTL3
Dual Capture Mode										
		T2 MODE = 1	—	—	T2C1 RST ENA	T2EDGE2 POLARITY	T2EDGE1 POLARITY	T2EDGE2 DET ENA	T2EDGE1 DET ENA	
106Dh	P06D	—	—	—	—	T2EVT DATA IN	T2EVT DATA OUT	T2EVT FUNCTION	T2EVT DATA DIR	T2PC1
106Eh	P06E	T2IC2/ PWM DATA IN	T2IC2/ PWM DATA OUT	T2IC2/ PWM FUNCTION	T2IC2/ PWM DATA DIR	T2IC1/CR DATA IN	T2IC1/CR DATA OUT	T2IC1/CR FUNCTION	T2IC1/CR DATA DIR	T2PC2
106Fh	P06F	T2 STEST	T2 PRIORITY	—	—	—	—	—	—	T2PRI

### 8.3.1 Timer 2 Control Register 1

The T2CTL1 register controls the clock input selection, counter overflow interrupts, and counter software reset.

**Timer 2 Control Register 1 (T2CTL1)**  
**[Memory Address – 106Ah]**

BIT#-	7	6	5	4	3	2	1	0
P06A	—	—	—	T2 OVRFL INT ENA	T2 OVRFL INT FLAG	T2 INPUT SELECT 1	T2 INPUT SELECT 0	T2 SW RESET
				RW-0	RC-0	RW-0	RW-0	S-0

R=Read, S=Set only, W=Write, C=Clear only, -n= Value after reset

Bit 0 - **T2 SW RESET.** Timer 2 Software Reset.  
 When a one is written to this bit, the counter will reset to 0000h on the next system clock cycle, however, this bit is always read as a zero.

Bits 1,2 - **T2 INPUT SELECT 0–1.** Timer 2 Input Select.  
 These two bits select one of four clock sources as an input to the counter. The four options are:  
 – system clock with no prescale,  
 – system clock when external input is high (pulse accumulation),  
 – external source synchronized with system clock (event input),  
 – no clock.  
 The combinations are shown below.

Bit 2	Bit 1	Counter Clock Source
0	0	system clock
0	1	pulse accumulation
1	0	event input
1	1	no clock input

Bit 3 - **T2 OVRFL INT FLAG.** Timer 2 Overflow Interrupt Flag.  
 This bit is the Timer 2 Counter Overflow Bit.

0 = Overflow interrupt inactive.  
 1 = Overflow interrupt pending.

Bit 4 - **T2 OVRFL INT ENA.** Timer 2 Overflow Interrupt Enable.  
 This bit controls the Timer 2 overflow interrupting capability.

0 = Disable Interrupt.  
 1 = Enable Interrupt from overflow.

Bits 5,6,7 - Reserved. Read data is indeterminate.



### 8.3.2 Timer 2 Control Register 2

The T2CTL2 register contains interrupt flags and controls the capability of the module to issue interrupts.

**Timer 2 Control Register 2 (T2CTL2)**  
**[Memory Address – 106Bh]**

**Mode: Dual Compare**

BIT#-	7	6	5	4	3	2	1	0
P06B	T2EDGE1 INT FLAG	T2C2 INT FLAG	T2C1 INT FLAG	—	—	T2EDGE1 INT ENA	T2C2 INT ENA	T2C1 INT ENA
	RC-0	RC-0	RC-0			RW-0	RW-0	RW-0

**Mode: Dual Capture**

BIT#-	7	6	5	4	3	2	1	0
P06B	T2EDGE1 INT FLAG	T2EDGE2 INT FLAG	T2C1 INT FLAG	—	—	T2EDGE1 INT ENA	T2EDGE2 INT ENA	T2C1 INT ENA
	RC-0	RC-0	RC-0			RW-0	RW-0	RW-0

R=Read, W=Write, C=Clear only, -n= Value after reset

- Bit 0 - **T2C1 INT ENA.** Timer 2 Compare 1 Interrupt Enable.  
 This bit controls the interrupting capability of the Compare 1 register.  
 0 = Disable interrupt.  
 1 = Enable interrupt from Compare 1 register.
- Bit 1 - *Dual Compare Mode:*  
**T2C2 INT ENA.** Timer 2 Output Compare 2 Interrupt Enable.  
 This bit controls the interrupting capability of the Compare 2 register.  
 0 = Disable interrupt.  
 1 = Enable interrupt from Compare 2 register.  
  
*Dual Capture Mode:*  
**T2EDGE2 INT ENA.** Timer 2 External Edge 2 Interrupt Enable.  
 This bit determines whether or not the active edge input to the T2IC2/PWM pin generates an interrupt.  
 0 = Disable interrupt.  
 1 = Enable interrupt.
- Bit 2 - **T2EDGE1 INT ENA.** Timer 2 External Edge 1 Interrupt Enable.  
 This bit determines whether or not the active edge input to the T2IC1/CR pin generates an interrupt.  
 0 = Disable interrupt.  
 1 = Enable interrupt.

- Bit 3,4 - Reserved. Read data is indeterminate.
- Bit 5 - **T2C1 INT FLAG.** Timer 2 Output Compare 1 Interrupt Flag.  
This bit is set when the output Compare Register first matches the counter value.  
0 = Interrupt inactive.  
1 = Interrupt pending from Compare 1.
- Bit 6 - *Dual Compare Mode:*  
**T2C2 INT FLAG.** Timer 2 Output Compare 2 Interrupt Flag.  
This bit is set when the Capture/Compare Register first matches the counter value.  
0 = Interrupt inactive.  
1 = Interrupt pending from Compare 2.
- Dual Capture Mode:*  
**T2EDGE2 INT FLAG.** Timer 2 Edge 2 Interrupt Flag.  
This bit is set when the appropriate edge is detected on T2IC2/PWM and indicates that the Capture Register was loaded.  
0 = Interrupt inactive.  
1 = Interrupt pending from Edge 2 Detect.
- Bit 7 - **T2EDGE1 INT FLAG.** Timer 2 External Edge 1 Interrupt Flag.  
This bit is set when the appropriate edge is detected on the T2IC1/CR pin.  
0 = Interrupt inactive.  
1 = Interrupt pending from Edge 1 Detect circuitry.

---

**Note:**

Be careful using the AND, OR, XOR, CMPBIT, SBIT0 or SBIT1 instruction to modify this register. The Read/Modify/Write nature of these instructions may inadvertently clear an interrupt flag that was set between the read and the write cycles. If the state of the interrupt enable bits is known, the MOV #n1,Pn2 instruction can be used. If the state of the interrupt enable bits is not known, a sequence similar to the example shown below should be used.

```
      ;Clearing the T2C1 INT FLAG
      MOV    P06B,A
      OR     #0E0h,A
      AND    #0DFh,A
      MOV    A,P06B
```

### 8.3.3 Timer 2 Control Register 3

The T2CTL3 register controls the Timer 2 module mode of operation, outputs, active transition polarity, and counter reset.

**Timer 2 Control Register 3 (T2CTL3)**  
[Memory Address – 106Ch]

**Mode: Dual Compare**

BIT#-	7	6	5	4	3	2	1	0
P06C	T2 MODE =0	T2C1 OUT ENA	T2C2 OUT ENA	T2C1 RST ENA	T2EDGE1 OUT ENA	T2EDGE1 POLAR- ITY	T2EDGE1 RST ENA	T2EDGE1 DET ENA
	RW-0	RW-0	RW-0	RW-0	RW-0	RW-0	RW-0	RW-0

**Mode: Dual Capture**

BIT#-	7	6	5	4	3	2	1	0
P06C	T2 MODE =1	—	—	T2C1 RST ENA	T2EDGE2 POLAR- ITY	T2EDGE1 POLAR- ITY	T2EDGE2 DET ENA	T2EDGE1 DET ENA
	RW-0			RW-0	RW-0	RW-0	RW-0	RW-0

R=Read, W=Write, -n= Value after reset

- Bit 0 - *Dual Compare Mode:*  
**T2EDGE1 DET ENA.** Timer 2 Edge 1 Detect Enable.  
 This bit enables the edge detection circuit to sense the next active level transition on the T2IC1/CR pin. This bit is cleared after the selected transition is detected or during reset.  
 0 = Edge 1 detect disabled.  
 1 = Edge 1 detect enabled.
- Dual Capture Mode:*  
**T2EDGE1 DET ENA.** Timer 2 Edge 1 Detect Enable.  
 This bit enables the edge detection circuit to sense the next active level transition on the T2IC1/CR pin. This bit remains unchanged after the selected transition is detected or during reset.  
 0 = Input capture disabled.  
 1 = Input capture enabled.
- Bit 1 - *Dual Compare Mode:*  
**T2EDGE1 RST ENA.** Timer 2 Edge 1 Detect Reset Enable.  
 This bit controls whether or not an external signal can reset the counter.  
 0 = Disable external reset of the counter.  
 1 = Enable external reset of the counter.
- Dual Capture Mode:*  
**T2EDGE2 DET ENA.** Timer 2 External Edge 2 Detect Enable.  
 This bit enables the edge detection circuit to sense the next active level transition on the T2IC2/PWM pin. This bit remains unchanged after the selected transition is detected or during reset.  
 0 = Edge detect disabled.  
 1 = Edge detect enabled.

- Bit 2 - **T2EDGE1 POLARITY.** Timer 2 Edge 1 Polarity Select.  
This bit controls which level transition on the T2IC1/CR pin is active.
- 0 = Trigger on high-to-low transition.  
1 = Trigger on low-to-high transition.
- Bit 3 - *Dual Compare Mode:*  
**T2EDGE1 OUT ENA.** Timer 2 Edge 1 Detect Output Enable.  
This bit controls whether or not the pulse indicating an external edge detect toggles the module's output pin.
- 0 = Disable pulse to toggle output.  
1 = Enable pulse to toggle output.
- Dual Capture Mode:*  
**T2EDGE2 POLARITY.** Timer 2 Edge 2 Polarity Select.  
This bit controls which level transition on the T2IC2/PWM 1 pin, will trigger a counter reset, depending upon the counter mode selected.
- 0 = Trigger on high-to-low transition.  
1 = Trigger on low-to-high transition.
- Bit 4 - **T2C1 RST ENA.** Timer 2 Output Compare 1 Reset Enable. This bit controls whether or not the compare equal pulse from the Compare Register resets the counter on the next counter increment.
- 0 = Disable reset upon compare equal.  
1 = Enable reset upon compare equal.
- Bit 5 - *Dual Compare Mode:*  
**T2C2 OUT ENA.** Timer 2 Output Compare 2 Enable.  
This bit controls whether or not the output compare equal pulse from the Capture/Compare Register toggles the T2IC2/PWM output pin.
- 0 = Disable pulse to toggle output.  
1 = Enable pulse to toggle output.
- Dual Capture Mode:*  
Reserved. Read data is indeterminate.
- Bit 6 - *Dual Compare Mode:*  
**T2C1 OUT ENA.** Timer 2 Output Compare 1 Enable.  
This bit controls whether or not the compare equal pulse from the Compare Register toggles T2IC2/PWM pin.
- 0 = Disable pulse from toggling output.  
1 = Enable pulse to toggle output.
- Dual Capture Mode:*  
Reserved. Read data is indeterminate.
- Bit 7 - **T2 MODE.** Timer 2 Mode Select.  
This bit selects the operating mode for the counter.
- 0 = Dual Compare mode.  
1 = Dual Capture mode.

### 8.3.4 Timer 2 Port Control Registers

The Port Control Registers (T2PC1, T2PC2) control the functions of the I/O pins. Each module pin is controlled by a nibble in one of the PCRs.

#### 8.3.4.1 Timer 2 Port Control Register 1

The T2PC1 register assigns the I/O function of the T2EVT pin as either a general-purpose digital I/O or external event input of the module.

**Timer 2 Port Control Register 1 (T2PC1)**  
**[Memory Address – 106Dh]**

BIT#-	7	6	5	4	3	2	1	0
P06D	—	—	—	—	T2EVT DATA IN	T2EVT DATA OUT	T2EVT FUNC- TION	T2EVT DATA DIR
					R-0	RW-0	RW-0	RW-0

R=Read, W=Write, -n= Value after reset

- Bit 0 - **T2EVT DATA DIR.** Timer 2 Event Pin Data Direction.  
 This bit determines the data direction on the T2EVT pin if the T2EVT FUNCTION bit = 0.  
 0 = T2EVT is configured as input.  
 1 = T2EVT is configured as output.
- Bit 1 - **T2EVT FUNCTION.** Timer 2 Event Pin Function Select.  
 This bit selects the function of the T2EVT pin.  
 0 = T2EVT is a general-purpose digital I/O pin.  
 1 = T2EVT is the event input pin.
- Bit 2 - **T2EVT DATA OUT.** Timer 2 Event Pin Data Out.  
 This bit contains the data to be output on the T2EVT pin if the following conditions are met:  
 a. T2EVT DATA DIR = 1  
 b. T2EVT FUNCTION = 0
- Bit 3 - **T2EVT DATA IN.** Timer 2 Event Pin Data In.  
 This bit contains the data to be input from the T2EVT pin. A write to this bit has no effect.
- Bits 4,5,6,7 -Reserved. Read data is indeterminate.

### 8.3.4.2 Timer 2 Port Control Register 2

The T2PC2 register assigns the I/O functions of the T2IC1/CR and T2IC2/PWM pins as either general-purpose digital I/O pins or the input-capture/counter-reset and PWM output pins, respectively.

**Timer 2 Port Control Register 2 (T2PC2)**  
**[Memory Address – 106Eh]**

BIT#-	7	6	5	4	3	2	1	0
P06E	T2IC2/ PWM DATA IN	T2IC2/ PWM DATA OUT	T2IC2/ PWM FUNC- TION	T2IC2/ PWM DATA DIR	T2IC1/ CR DATA IN	T2IC1/ CR DATA OUT	T2IC1/ CR FUNC- TION	T2IC1/ CR DATA DIR
	R-0	RW-0	RW-0	RW-0	R-0	RW-0	RW-0	RW-0

R=Read, W=Write, -n= Value after reset

- Bit 0 - **T2IC1/CR DATA DIR.** Timer 2 IC1/CR Data Direction.  
 This bit determines the direction of data on the T2IC1/CR pin if the T2IC1/CR FUNCTION bit = 0.  
 0 = T2IC1/CR is an input.  
 1 = T2IC1/CR is an output.
- Bit 1 - **T2IC1/CR FUNCTION.** Timer 2 IC1/CR Function Select.  
 This bit determines the function of the T2IC1/CR pin.  
 0 = T2IC1/CR is a general-purpose digital I/O pin.  
 1 = T2IC1/CR is the input capture/counter reset pin.
- Bit 2 - **T2IC1/CR DATA OUT.** Timer 2 IC1/CR Data Out.  
 This bit contains the data output on the T2IC1/CR pin if the following conditions are true:  
 a. T2IC1/CR DATA DIR = 1  
 b. T2IC1/CR FUNCTION = 0
- Bit 3 - **T2IC1/CR DATA IN.** Timer 2 IC1/CR Data In.  
 This bit contains the data input on the T2IC1/CR pin. A write to this bit has no effect.
- Bit 4 - **T2IC2/PWM DATA DIR.** Timer 2 IC2/PWM Data Direction.  
 This bit determines the direction of data on the T2IC2/PWM pin if the T2IC2/PWM FUNCTION bit = 0.  
 0 = T2IC1/PWM is an input.  
 1 = T2IC2/PWM is an output.
- Bit 5 - **T2IC2/PWM FUNCTION.** Timer 2 IC2/PWM Function Select.  
 This bit determines the function of the T2IC2/PWM pin.  
 0 = T2IC2/PWM is a general-purpose digital I/O pin.  
 1 = T2IC2/PWM is the input capture/PWM output pin.

8

- Bit 6 - **T2IC2/PWM DATA OUT.** Timer 2 IC2/PWM Data Out.  
This bit contains the data output on the T2IC2/PWM pin if the following conditions are true:  
a. T2IC2/PWM DATA DIR = 1  
b. T2IC2/PWM FUNCTION = 0
- Bit 7 - **T2IC2/PWM DATA IN.** Timer 2 IC2/PWM Data In.  
This bit contains the data input on the T2IC2/PWM pin. A write to this bit has no effect.

**Note:**

See Section 14.6.1 for examples of PWM pin initialization.

### 8.3.5 Timer 2 Interrupt Priority Control Register

The T2PRI register assigns the priority level of interrupts generated by the Timer 2 module.

**Timer 2 Priority Control Register (T2PRI)**  
**[Memory Address – 106Fh]**

BIT#-	7	6	5	4	3	2	1	0
P06F	T2 STEST	T2 PRIOR- ITY	—	—	—	—	—	—
	RP-0	RP-0						

R=Read, P=Privileged Write, -n= Value after reset

Bits 0-5 - Reserved. Read data is indeterminate.

Bit 6 - **T2 PRIORITY.** Timer 2 Interrupt Priority Select.  
 This bit determines the level of Timer 2 interrupts.

0 = Interrupts are level 1 (high priority) requests.  
 1 = Interrupts are level 2 (low priority) requests.

Bit 7 - **T2 STEST.**  
 This bit must be cleared to ensure proper operation.



Introduction	1
Assembly Language Instruction Set	13
TMS370 Family Devices	2
Design Aids	14
CPU and Memory Organization	3
Development Support	15
System and Digital I/O Configuration	4
Electrical Specifications	16
Interrupts and System Reset	5
Customer Information	17
EEPROM Modules	6
Appendices	A-H
Timer 1 Module	7
Timer 2 Module	8
Serial Communications Interface (SCI) Port	9
Serial Peripheral Interface (SPI) Module	10
Analog-to-Digital Converter Module	11
TMS370 Programmable Acquisition and Control Timer	12



# Serial Communications Interface (SCI) Port

---

---

---

---

This chapter discusses the architecture and programming of the Serial Communications Interface module and covers the following topics:

<b>Section</b>	<b>Page</b>
9.1 SCI Overview .....	9-2
9.2 SCI Operation .....	9-6
9.3 SCI Control Registers .....	9-19

## 9.1 SCI Overview

The programmable Serial Communications Interface (SCI) allows digital communications between the TMS370 device and other asynchronous peripherals using the standard NRZ (Non Return to Zero) format. Both the SCI receiver and transmitter are double buffered and have their own separate enable and interrupt bits. They may be operated independently or simultaneously in the Full Duplex mode.

To ensure data integrity the SCI checks received data for Break detection, Parity, Overrun, and Framing errors. The speed of operation, or Baud rate, is programmable to over 65,000 different speeds through a 16-bit baud-select register.

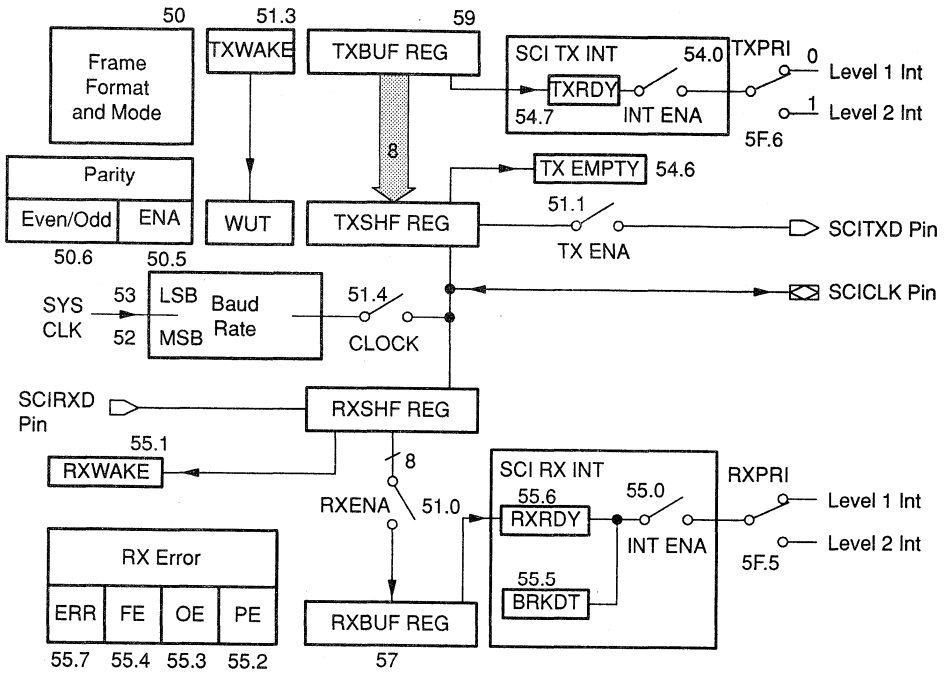
### 9.1.1 Physical Description

The major elements of the full-duplex SCI are shown in Figure 9–1 and includes:

- 1) a transmitter (TX),
  - a) TXBUF – Transmitter Buffer Register, contains data written by the CPU, to be transmitted.
  - b) TXSHF – Transmitter Shift Register, loaded from TXBUF, shifts data onto SCITXD pin one bit at a time.
- 2) a receiver (RX),
  - a) RXSHF – Receiver Shift Register, shifts data in from SCIRXD pin one bit at a time.
  - b) RXBUF – Receiver Buffer Register, contains data to be read by the CPU, received from remote processor, loaded from RXSHF.
- 3) a programmable baud rate generator, and
- 4) memory mapped control and status registers.

The SCI receiver and transmitter can operate independently and simultaneously. A third port line (SCICLK) is available for the optional synchronizing clock line in the Isosynchronous mode.

Figure 9–1. SCI Block Diagram



## 9.1.2 SCI Features

Features of the Serial Communications Interface (SCI) include the following:

- ❑ Two Communications Formats
  - Asynchronous
  - Isosynchronous
- ❑ Programmable Baud Rates
  - Asynchronous:
    - Range at 20 MHz – 3 Bps to 156 K Bps
    - Number of Baud Rates – 64K
  - Isosynchronous:
    - Range at 20 MHz – 39 Bps to 2.5 M Bps
    - Number of Baud Rates – 64 K
- ❑ Programmable Data Word Length From 1 To 8 Bits
- ❑ Programmable Stop Bits Of Either 1 Or 2 Bits In Length

- ❑ Error Detection Flags:
  - Parity Error
  - Overrun Error
  - Framing Error
  - Break Detect
- ❑ Two Wake-Up Multiprocessor Modes which may be used with either Communications Format.
  - Idle Line Wake-Up
  - Address Bit Wake-Up
- ❑ Full Duplex Operation
- ❑ Separate Transmitter and Receiver Interrupts For Polled or Interrupt Driven Operation
- ❑ Double Buffered Receive and Transmit Functions
- ❑ Separate Enable Bits for the Transmitter and Receiver.
- ❑ NRZ (Non-Return-to-Zero) Format.

### 9.1.3 SCI Formats and Operation Modes

The SCI may use one of two communication formats, Asynchronous or Isosynchronous. These formats may be programmed to contain:

- ❑ 1 start bit,
- ❑ 1 to 8 data bits,
- ❑ an even/odd parity bit or no parity bit, and
- ❑ 1 or 2 stop bits.

The SCI provides the following Universal Asynchronous Receiver/Transmitter (UART) communications formats for interfacing with many popular peripherals:

- ❑ Asynchronous Mode (discussed in Section 9.2.4.1 ) requires two lines to interface with many standard devices such as terminals and printers using RS-232-C formats.
- ❑ Isosynchronous Mode (discussed in Section 9.2.4.2) permits high transmission rates and requires a synchronizing clock signal between the receiver and transmitter.

The SCI also has two multiprocessor protocols, the **Idle Line** Multiprocessor Mode (see Section 9.2.5.1) and the **Address Bit** Multiprocessor Mode (see Section 9.2.5.2). These protocols allow efficient data transfer between multiple processors, and may be used with either the Isosynchronous or standard Asynchronous formats.

The SCI transmits and receives serial data, one bit at a time at a programmable baud rate. If the TMS370 operates at 20 MHz, the Baud rate for the Asynchronous mode would range from 3 bits-per-second to 156 kilobits-per-second, and for the Isosynchronous mode would range from 39 bits-per-second to 2.5 megabits-per-second.

### 9.1.4 SCI Control Registers

The SCI Control registers are located at addresses 1050h to 105Fh. The function of each location is shown in Table 9–1.

**Table 9–1. SCI Memory Map**

Peripheral File Location	Symbol	Name
P050	SCICCR	SCI Communication Control Register
P051	SCICTL	SCI Control Register
P052	BAUD MSB	Baud Rate Select MSB
P053	BAUD LSB	Baud Rate Select LSB
P054	TXCTL	Transmitter Interrupt Control and Status Register
P055	RXCTL	Receiver Interrupt Control and Status Register
P056		Reserved
P057	RXBUF	Receiver Data Buffer
P058		Reserved
P059	TXBUF	Transmit Data Buffer
P05A		Reserved
P05B		
P05C		
P05D	SCIPC1	Port Control 1
P05E	SCIPC2	Port Control 2
P05F	SCIPRI	Priority Control

## 9.2 SCI Operation

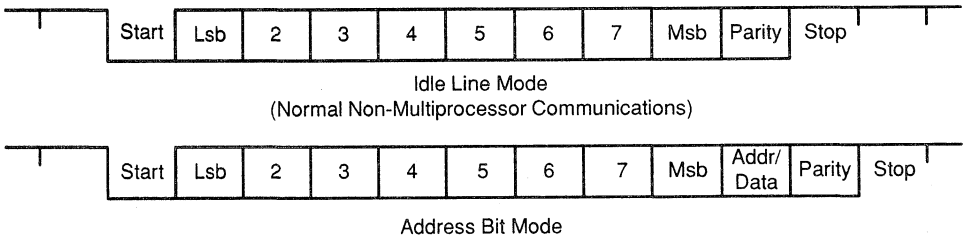
The functions of the SCI are software configurable. A set of control words sent to the SCI initializes the desired communications format. These control words determine the:

- 1) operating mode and protocol,
- 2) baud rate,
- 3) character length,
- 4) even/odd parity or parity off,
- 5) number of stop bits, and
- 6) interrupt priorities and enables.

### 9.2.1 SCI Programmable Data Format

SCI data, both receive and transmit, is in NRZ (Non-Return to Zero) format. The data format consists of one Start bit, 1 to 8 data bits, an optional even/odd parity bit, and either 1 or 2 Stop bits, as illustrated in Figure 9–2. In addition, the Address Bit mode employs an extra bit to distinguish addresses from data.

**Figure 9–2. SCI Data Frame Formats**



9

### 9.2.2 SCI Port Interrupts

The SCI provides independent interrupt requests and vectors for the receiver and transmitter.

The receiver interrupt is asserted when the RXRDY (RXCTL.6) or BRKDT (TXCTL.5) flags are set, assuming the SCI RX INT ENA bit (RXCTL.0) is set. The transmitter interrupt is asserted when the TXRDY flag (TXCTL.7) is set, assuming the SCI TX INT ENA bit (TXCTL.0) is set.

SCI interrupts can be programmed onto different priority levels by the SCI RX PRIORITY (SCIPRI.5) and SCI TX PRIORITY (SCIPRI.6) control bits. When both RX and TX interrupt requests are made on the same level, the receiver always has higher priority than the transmitter to reduce the possibility of receiver overrun.



An SCI TX interrupt is asserted whenever TXBUF is transferred to TXSHF. This interrupt indicates that the CPU can write to the TXBUF.

An SCI RX interrupt is asserted whenever the SCI receives a complete frame (RXSHF transfers to RXBUF) or when a break detect condition occurs (SCIRXD is low for 10 bit periods following a stop bit).

### 9.2.3 SCI Clock Sources

The SCI port can be driven by an internal or external baud rate generator. The CLOCK bit (SCICTL.4) configures the SCI clock source as either an input or an output.

If an external clock source is selected (CLOCK = 0), and the SCICLK FUNCTION bit (SCIPC1.1) is set, then the SCICLK pin functions as the high impedance Serial Clock input pin.

If an internal clock source is selected (CLOCK = 1), the SCICLK pin may be used as a general purpose I/O pin or as the Serial Clock output pin. If the Serial Clock output is selected, a 50 percent duty cycle clock signal is output on the SCICLK pin, which becomes a Serial Clock output pin.

The internally generated serial clock is determined by the TMS370 CLKIN frequency and the Baud Rate Select Registers. The SCI uses the 16-bit value of the Baud Rate Select Registers to select one of 64K different serial clock rates for the communication modes in the following manner:

$$\text{Asynchronous Baud Rate} = \text{CLKIN} / [(\text{BAUD RATE REG} + 1) \times 128]$$

$$\text{Isosynchronous Baud Rate} = \text{CLKIN} / [(\text{BAUD RATE REG} + 1) \times 8]$$

$$\text{SCICLK frequency} = \text{CLKIN} / [(\text{BAUD RATE REG} + 1) \times 8]$$

where

BAUD RATE REG = The 16-bit value in the Baud Rate Select Registers.

#### Note:

When using an externally generated SCICLK in Isosynchronous mode, the maximum speed at which the SCICLK can run is limited to CLKIN/40. This is necessary so that the internal clocks of the SCI have time to synchronize with the external clock. For this reason it is recommended to use the TMS370 to drive the master serial clock in a system where maximum throughput is a major concern.

The current logic level on the SCICLK pin can be determined by reading the SCICLK DATA IN bit (SCIPC1.3).

The SCI receives data on rising clock edges and transmits data on falling clock edges.

**Table 9–2. Asynchronous Baud Rate Register Values for Common SCI Baud Rates**

Baud Rate	Crystal Oscillator Frequency (MHz)							
	2.4576		7.3728		19.6608		20.0	
	BR Reg	% Error	BR Reg	% Error	BR Reg	% Error	BR Reg	% Error
75	255	0.00	767	0.00	2047	0.00	2082	0.02
300	63	0.00	191	0.00	511	0.00	520	-0.03
600	31	0.00	95	0.00	255	0.00	259	0.16
1200	15	0.00	47	0.00	127	0.00	129	0.16
2400	7	0.00	23	0.00	63	0.00	64	0.16
4800	3	0.00	11	0.00	31	0.00	32	-1.38
9600	1	0.00	5	0.00	15	0.00	15	1.73
19200	0	0.00	2	0.00	7	0.00	7	1.73
38400	-	-	-	-	3	-	3	1.73
156000	-	-	-	-	-	-	0	0.16

BR Reg = 16 bit Baud rate register value

## 9.2.4 SCI Communications Modes

The SCIRX/SCITX (receiver/transmitter) has two operating modes, Asynchronous and Isosynchronous. The ASYNC/ISOSYNC bit (SCICCR.4) determines the mode of operation. Either of these two modes can be used with either of the two forms of multiprocessor protocol, Idle Line and Address Bit.

### 9.2.4.1 Asynchronous Communications Mode

The SCI Asynchronous communication mode uses either single line (one way) or double line (two way) communications. In this mode, the frame consists of a start bit, one to eight data bits, an optional even/odd parity bit, and one or two stop bits. There are 16 SCICLK periods per data bit.

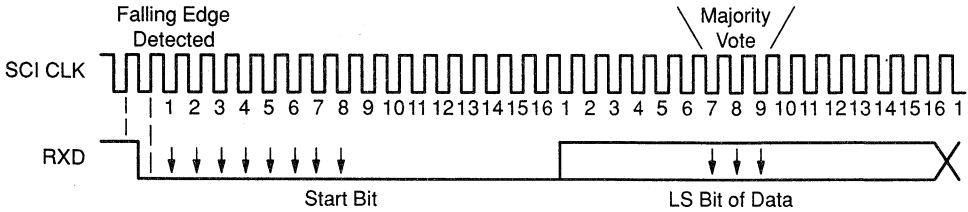
The receiver begins operation on receipt of a valid start bit. A valid start bit consists of eight consecutive zero bits. If any bit is not zero then the processor starts over and begins looking for another start bit.

For the bits following the start bit, the processor determines the bit value by making three samples in the middle of the bit. These samples occur on the seventh, eighth, and ninth SCICLK period and are read on a majority (two out of three) basis. Figure 9–3 illustrates the asynchronous communication format, with a start bit showing how edges are found and where a majority vote is taken.

Since the receiver synchronizes itself to frames, the external transmitting and receiving devices do not have to use a synchronized serial clock; it may

be generated locally. If the CLOCK (SCICTL.4) and SCICLK FUNCTION (SCIPC1.1) bits are set, the serial clock is output continuously on the SCICLK pin.

**Figure 9–3. Asynchronous Communication Format**



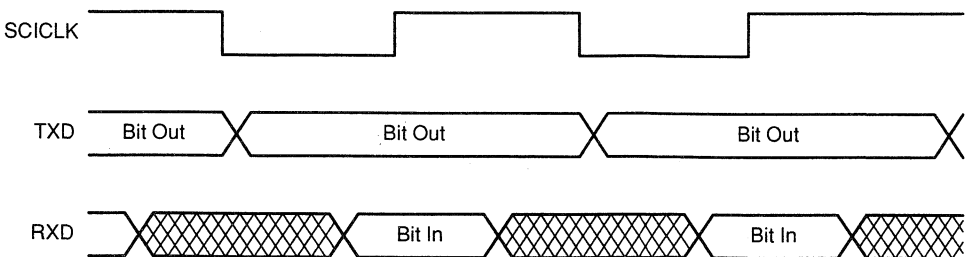
**9.2.4.2 SCI Isosynchronous Communications Mode**

The SCI Isosynchronous communication mode uses either two line (one way) or three line (two way) communications. The extra line (Serial Clock) is required for data synchronization. In the Isosynchronous mode, each bit of data requires only one serial clock pulse for transmission or reception. Thus the data bit period equals the SCICLK period, and data bits are read on a single sample basis.

Since the receiver does not synchronize itself to data bits, the transmitter and receiver must be supplied with a common serial clock. If the internal serial clock is used it must be output continuously on the SCICLK pin. The arrival of a valid start bit, which consists of a low on the RXD line at the time of a rising SCICLK edge, initiates receiver operation.

Figure 9–4 illustrates the Isosynchronous communication format. A complete frame consists of a start bit, one to eight data bits, an optional even/odd parity bit, and one or two stop bits.

**Figure 9–4. Isosynchronous Communication Format**



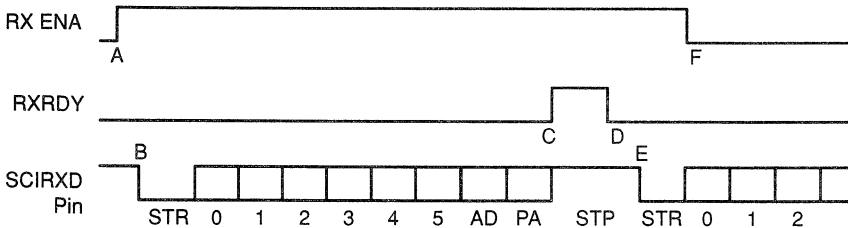
**9.2.4.3 Receiver Signals in Communications Modes**

Figure 9–5 illustrates an example of receiver signal timing assuming the following:

- 1) Address bit wake-up mode
- 2) 6 bits per character

Lettered notes following the diagram are keyed to the letter labels in the diagram.

**Figure 9–5. SCI RX Signals in Communication Modes**



- A) RX ENA goes high to enable the receiver.
- B) Data arrives on the SCIRXD pin, start bit detected.
- C) RXRDY goes high to signal that a new character has been received, data is shifted to RXBUF, an interrupt is requested.
- D) The program reads the RXBUF register, RXRDY is automatically cleared.
- E) The next byte of data arrives on the SCIRXD pin; start bit detected. cleared.
- F) RX ENA goes low to disable the receiver. Data continues to be assembled in the RXSHF register but is not transferred to the RXBUF register.

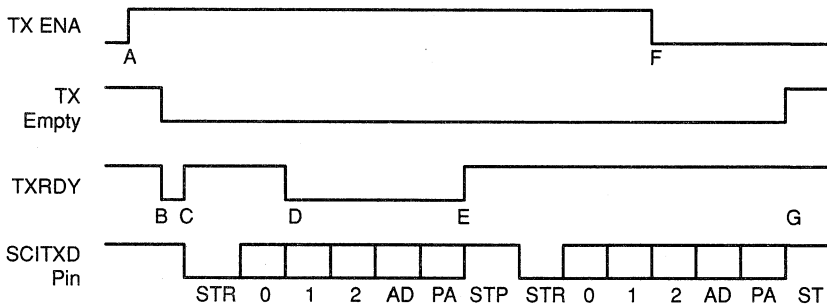
### 9.2.4.4 Transmitter Signals in Communications Modes

Figure 9–6 illustrates an example of transmitter signal timing assuming the following:

- 1) Address bit wake-up mode (address bit would not appear in Idle line mode)
- 2) 3 bits per character

Lettered notes following the diagram are keyed to the letter labels in the diagram.

**Figure 9–6. SCI TX Signals in Communications Modes**



- A) TX ENA goes high to enable the transmitter to send data.
- B) Write to TXBUF, TX is no longer empty.
- C) SCI transfers data to shift register; TX is ready for new character, requests an interrupt.
- D) Program writes new character to TXBUF after TXRDY goes high (item C).
- E) Finished transmitting first character; transfer new character to shift register.
- F) TX ENA goes low to disable transmitter; SCI finishes transmitting current character.
- G) Finished transmitting character; TX is empty and ready for new character.

### 9.2.5 SCI Multiprocessor Communications

9

The Multiprocessor Communication format allows one processor to efficiently send blocks of data to other processors on the same serial link. On one serial line there should be only one talker at a time. The first byte of a block of information contains an address byte which is read by all listeners. Only correctly addressed listeners can be interrupted by the following data bytes. The listeners not addressed remain uninterrupted until the next address byte.

The two different multiprocessor modes differ in how the processor recognizes an address byte. The **Idle Line** mode leaves a quiet space before the address byte. The **Address Bit** mode adds an extra bit into every byte to distinguish addresses from data.

The multiprocessor mode is software selectable via the ADDRESS/IDLE WUP bit (SCICCR.3). Both formats use the TXWAKE and SLEEP flags to control the SCITX and SCIRX features of these modes.

All processors on the serial link set their SLEEP bit to 1 so that they are interrupted only when the address byte is detected. When a processor reads a block address which corresponds to the CPU's device address as set by software the program must clear the SLEEP bit to enable the SCI to generate an interrupt on receipt of each data byte.

Although the receiver still operates when the SLEEP bit is 1, it does not set RXRDY, RXINT, or the error status bits to 1 unless the address byte is detected and the address bit in the received frame is a 1. The SCI does not alter the SLEEP bit; software must alter the SLEEP bit.

In both multiprocessor modes the sequence is:

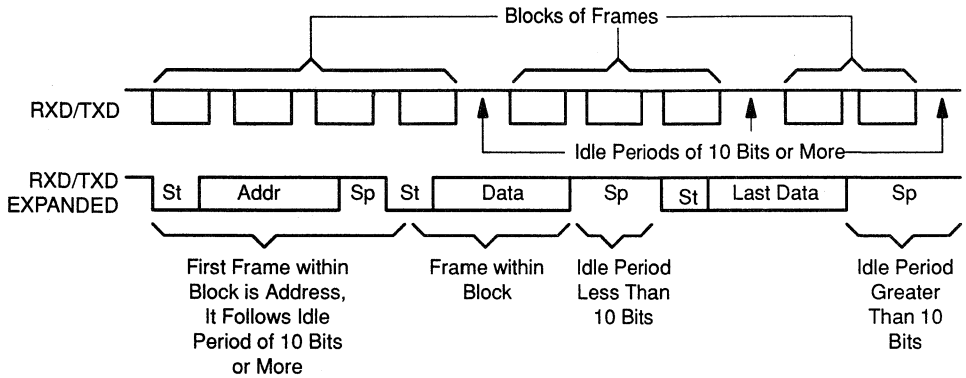
- 1) The SCI port wakes up (requests an interrupt) at the start of a block and reads the first frame which contains the destination address.
- 2) A software routine is entered through the interrupt and checks the incoming byte against its device address byte stored in memory.
- 3) If the block is addressed to the microcomputer, the CPU clears the SLEEP bit and reads the rest of the block; if not, the software routine exits with the SLEEP bit still set and does not receive SCI interrupts until the next block start.

The Idle Line multiprocessor mode does not contain the extra address/data bit, and is more efficient than the Address Bit mode in handling blocks containing more than 10 bytes of data.

The Address Bit mode is more efficient in handling many small blocks of data because it does not have to wait between blocks of data as does the Idle Line mode. However, at high transmit speeds, the program may not be quick enough to avoid a 10-bit idle in the transmission stream.

### 9.2.5.1 Idle Line Multiprocessor Mode

In the Idle Line multiprocessor protocol, blocks are separated by having a longer idle time between the blocks than between frames in the blocks. An idle time of 10 or more bits after a frame indicates the start of a new block. The Idle Line multiprocessor communication format is shown in Figure 9–7.

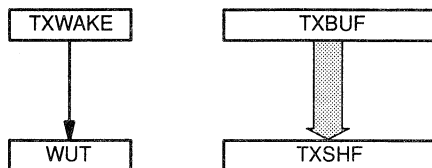
**Figure 9–7. Idle Line Multiprocessor Communication Format**

The SCI wakes up after the block start signal. The processor now recognizes the next SCI interrupt. The service routine then receives the address sent by a remote transmitter and compares this address to its own. If the CPU is addressed, the service routine clears the SLEEP bit, and receives the rest of the data block. If the CPU is not addressed, the SLEEP bit is left set. This lets the CPU continue to execute its main program without being interrupted by the SCI port.

There are two ways to send a block start signal.

- 1) The first method is to deliberately leave an idle time of 10 bits or more by delaying the time between the transmission of the last frame of data in the previous block and the address frame of the new block.
- 2) In the second method, the SCI port uses the TXWAKE bit to send an idle time of exactly 11 bits. Therefore, the serial communications line is not idle any longer than necessary.

Associated with the TXWAKE bit is the wake-up temporary (WUT) flag. WUT is an internal flag, double buffered with TXWAKE. When TXSHF is loaded from TXBUF, WUT is loaded from TXWAKE, and TXWAKE is reset to 0. This arrangement is shown in Figure 9–8.

**Figure 9–8. Double-Buffered WUT and TXSHF**

To send out a block start signal of exactly one frame time:

- 1) Write a 1 to the TXWAKE bit.
- 2) Write a data word (don't care) to TXBUF. (The first data word written is suppressed while the block start signal is sent out, and ignored after that.)

When TXSHF is free again, TXBUF's contents are shifted to TXSHF, the TXWAKE value is shifted to WUT, and then TXWAKE is cleared.

If TXWAKE was set to a 1, the start, data, and parity bits are replaced by an idle period of 11 bits transmitted following the last stop bit of the previous frame.

- 3) Write an address value to the TXBUF.

Writing the first don't-care data word to the TXBUF is necessary so the TXWAKE bit value can be shifted to WUT. After the don't-care data word is shifted to the TXSHF, the TXBUF (and TXWAKE if necessary) may be written to again, since WUT and TXSHF are both double-buffered.

The receiver operates regardless of the SLEEP bit. The receiver does not set RXRDY, RXINT, or the error status bits until an address frame is detected.

### **9** 9.2.5.2 Address Bit Multiprocessor Mode

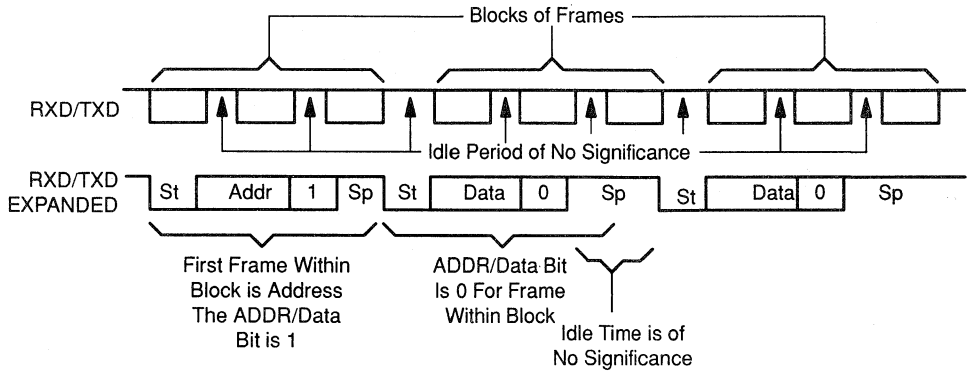
In the Address Bit protocol, the frame has an extra bit called an address bit immediately after the last data bit. The first frame in the block has the address bit set to 1, and all other frames have the address bit set to 0. The idle period timing is irrelevant.

The TXWAKE bit sets the address bit. In SCITX, when the TXBUF and TXWAKE are loaded into TXSHF and WUT, TXWAKE is reset to 0 and WUT is the value of the address bit of the current frame. Thus, to send an address, set the TXWAKE bit to a 1, and write the appropriate address value to the TXBUF. When this address value is transferred to TXSHF and shifted out, its address bit is sent as a 1, which flags the other processors on the serial link to read the address. Since TXSHF and WUT are both double-buffered,



TXBUF and TXWAKE may be written to immediately after TXSHF and WUT are loaded. To transmit non-address frames in the block, the TXWAKE bit is left at 0.

**Figure 9–9. Address Bit Multiprocessor Communication Format**



### 9.2.6 SCI Initialization Examples

This section contains two examples that initialize the serial port. In each case the data is moved to and from the buffers in the interrupt routines.

- ❑ The first example shows a typical RS-232 application that connects to a terminal.
- ❑ The second example illustrates the Address Bit mode in a multiprocessor application.

In all examples, assume the register mnemonics have been equated (EQU) with the corresponding Peripheral-File location. For more examples using the TMS370 SCI, consult *Using the TMS370 SPI and SCI Modules Application Report*, literature number SPNA006.

### 9.2.6.1 RS-232-C Example

This example initializes the transmitter and receiver to accept data at 9600 baud with a format of 8 data bits, 1 stop bit, and even parity.

```

B9600    .EQU    15                ;Value for counter for 9600 baud
                                           ;value = (CLKIN/128/baud rate) - 1 =
                                           ;(20 MHz/128/9600) - 1 = 15.27 ~ 15
                                           ;1.8 percent error
        AND     #01Fh, SCICTL      ;Make sure that SCI SW RESET bit is
                                           ;clear before writing to the SCI
                                           ;configuration registers
        MOV     #000h, SCIPRI      ;Set TX and RX to high priority
        MOV     #005h, SCIPC1     ;Set SCLK for general purpose output
        MOV     #022h, SCIPC2     ;Set pins for RXD and TXD functions
        MOV     #Hi B9600, BAUDMSB ;Set baud rate for 9600 (MSB)
        MOV     #Lo B9600, BAUDLSB ;Set baud rate for 9600 (LSB)
        MOV     #077h, SCICCR     ;1 stop bit, even parity,
                                           ;and 8 data bits/char
        MOV     #033h, SCICTL     ;Enable Rx, Tx, clock is internal
        MOV     #001h, TXCTL      ;Enable TX interrupt
        MOV     #001h, RXCTL      ;Enable RX interrupt
        EINT                               ;Let the interrupts begin
        MOV     #00, TXBUF        ;Start transmitter by sending null
                                           ;character
    
```

### 9.2.6.2 RS-232-C Multiprocessor Mode Example

This example initializes the transmitter and receiver to accept data at 9600 baud with a format of 8 data bits, 1 stop bit, and even parity. It uses the address bit wake-up mode to implement the multiprocessor protocol.

```

B9600      .EQU      15                ;Value for counter for 9600 baud
                                                ;value=(CLKIN/128/baud rate) - 1 =
                                                ;(20 MHz/128/9600) - 1 = 15.27 ~ 15
                                                ;1.8 percent error
MOV        #000h,SCIPRI                ;Set TX and RX to high priority
MOV        #005h,SCIPC1                ;Set SCLK for general purpose output
MOV        #022h,SCIPC2                ;Set pins for RXD and TXD functions
MOV        #Hi B9600,BAUDMSB           ;Set baud rate for 9600 (MSB)
MOV        #Lo B9600,BAUDLSB          ;Set baud rate for 9600 (LSB)
MOV        #07Fh,SCICCR                ;1 stop bit, even parity,
                                                ;and 8 data bits/char
MOV        #037h,SCICTL                ;Enable Rx, Tx; RX to sleep,
                                                ;clock is internal
MOV        #001h,TXCTL                ;Enable TX interrupt
MOV        #001h,RXCTL                ;Enable RX interrupt
EINT                                             ;Let the interrupts begin
                                                ;
                                                ;MAIN ROUTINES
                                                ;

SENDADD    OR        #8,SCICTL          ;Main line routine; set TXWAKE
                                                ;wake bit
MOV        ADDR,TXBUF                  ;Transmit address stored in ADDR
RTS                                             ;
                                                ;INTERRUPT ROUTINES
                                                ;
                                                ;The locations of the SCI transmitter and
                                                ;receiver routines, SENDATA and GETDATA,
                                                ;need to be stored in the interrupt vector
                                                ;table at locations 70F0h and 7FF2h,
                                                ;respectively.
                                                ;SCI TRANSMITTER INTERRUPT ROUTINE

SENDATA    PUSH      A                 ;Address has already been sent by
                                                ;the SENDADD
MOV        OUTDATA,TXBUF               ;Output character that is
                                                ;stored in DATA
.                                             ;
.                                             ;Other transmitter code
.                                             ;
POP        A                            ;Restore and exit
RTI                                             ;
                                                ;SCI RECEIVER INTERRUPT ROUTINE

GETDATA    PUSH      A                 ;Receive a new character
BTJZ      #2,RXCTL,ISDATA              ;Is this address or data byte?
MOV        RXBUF,A                     ;Get new character and clear
                                                ;interrupt flag
CMP        #MYADDR,A                   ;Is this my address or
                                                ;another processor's address
JNE       RXEXIT                       ;Exit if another's; still
                                                ;in sleep mode
AND       #0FBh,SCICTL                 ;If my address get out of sleep mode
JMP       RXEXIT                       ;Exit and wait for data
                                                ;

```

## SCI Operation

---

```
ISDATA  MOV    RXBUF,INDATA    ;Put incoming data in register
        .
        .
        .
        .
RXEXIT  POP    A                ;Restore and exit
        RTI
```

### 9.3 SCI Control Registers

The SCI is controlled and accessed through registers in the peripheral file. These registers are listed in Table 9–3 and described in the following sections. The bits shown in shaded boxes in Table 9–3 are Privilege Mode bits, that is, they can only be written to in the Privilege Mode.

**Table 9–3. SCI Control Registers**

ADDR	PF	7	6	5	4	3	2	1	0	
1050h	P050	STOP BITS	EVEN/ ODD PARITY	PARITY ENABLE	ASYNC/ ISOSYNC	ADDRESS / IDLE WUP	SCI CHAR2	SCI CHAR1	SCI CHAR0	SCICCR
1051h	P051	—	—	SCI SW RESET	CLOCK	TXWAKE	SLEEP	TXENA	RXENA	SCICTL
1052h	P052	BAUDF (MSB)	BAUDE	BAUDD	BAUDC	BAUDB	BAUDA	BAUD9	BAUD8	BAUD MSB
1053h	P053	BAUD7	BAUD6	BAUD5	BAUD4	BAUD3	BAUD2	BAUD1	BAUD0 (LSB)	BAUD LSB
1054h	P054	TXRDY	TX EMPTY	—	—	—	—	—	SCI TX INT ENA	TXCTL
1055h	P055	RX ERROR	RXRDY	BRKDT	FE	OE	PE	RXWAKE	SCI RX INT ENA	RXCTL
1056h	P056	RESERVED								
1057h	P057	RXDT7	RXDT6	RXDT5	RXDT4	RXDT3	RXDT2	RXDT1	RXDT0	RXBUF
1058h	P058	RESERVED								
1059h	P059	TXDT7	TXDT6	TXDT5	TXDT4	TXDT3	TXDT2	TXDT1	TXDT0	TXBUF
105Ah	P05A	RESERVED								
105Bh	P05B									
105Ch	P05C									
105Dh	P05D	—	—	—	—	SCICLK DATA IN	SCICLK DATA OUT	SCICLK FUNCTION	SCICLK DATA DIR	SCIPC1
105Eh	P05E	SCITXD DATA IN	SCITXD DATA OUT	SCITXD FUNCTION	SCITXD DATA DIR	SCIRXD DATA IN	SCIRXD DATA OUT	SCIRXD FUNCTION	SCIRXD DATA DIR	SCIPC2
105Fh	P05F	SCI TEST	SCI TX PRIORITY	SCI RX PRIORITY	SCI ESPEN	—	—	—	—	SCIPRI

### 9.3.1 Communication Control Register (SCICCR)

The SCICC Register defines the character format, protocol, and communications mode used by the SCI.

**SCI Communication Control Register (SCICCR)**  
[Memory Address – 1050h]

BIT#-	7	6	5	4	3	2	1	0
P050	STOP BITS	EVEN / ODD PARITY	PARITY ENABLE	ASYNC/ ISOSYNC	ADDRESS / IDLE WUP	SCI CHAR2	SCI CHAR1	SCI CHAR0
	RW-0	RW-0	RW-0	RW-0	RW-0	RW-0	RW-0	RW-0

R=Read, W=Write, -n= Value after reset

Bits 0–2 - **SCI CHAR0—2** SCI Character Length Control Bits 0 — 2.  
These bits select the SCI character length, from 1 to 8 bits. Characters of less than 8 bits are right-justified in RXBUF and TXBUF, and are padded with leading 0s in RXBUF. TXBUF need not be padded with leading zeros.

**Table 9–4. Transmitter Character Bit Length**

SCI CHAR2	SCI CHAR1	SCI CHAR0	Character Length
0	0	0	1
0	0	1	2
0	1	0	3
0	1	1	4
1	0	0	5
1	0	1	6
1	1	0	7
1	1	1	8

Bit 3 - **ADDRESS/IDLE WUP.** SCI Multiprocessor Mode Control Bit.  
This bit selects one of the multiprocessor protocols.

- 0 = Idle Line Mode protocol selected.
- 1 = Address Bit Mode protocol selected.

The Idle Line Mode is usually used for normal communications because the Address Bit Mode adds an extra bit to the frame. The Idle Line Mode does not add this extra bit and is compatible with RS-232-type communications. Multiprocessor communication is different from the other communication modes because it uses TXWAKE and SLEEP functions.

- Bit 4 - ASYNC/ISOSYNC.** SCI Communications Mode Control Bit.  
This bit determines the SCI communications mode.
- 0 = Selects Isosynchronous mode (described in Section 9.2.4.2). In this mode, the bit period is equal to the SCICLK period; bits are read on a single sample basis.
  - 1 = Selects Asynchronous mode (described in Section 9.2.4.1). In this mode the bit period is 16 times the SCICLK period; bits are read on a two out of three majority basis.
- Bit 5 - PARITY ENABLE.** SCI Parity Enable.  
This bit enables or disables the parity function. When parity is enabled during the Address Bit multiprocessor mode, the address bit is included in the parity calculation.
- 0 = Parity disabled. No parity bit is generated during transmission or expected during reception.
  - 1 = Parity enabled.
- Bit 6 - EVEN/ODD PARITY.** SCI Parity Odd/Even.  
If the PARITY ENABLE (SCICCR.5) is set, then this bit selects odd or even parity (odd or even number of 1 bits in both transmitted and received characters).
- 0 = Sets odd parity.
  - 1 = Sets even parity.
- Bit 7 - STOP BITS.** SCI Number of Stop Bits.  
This bit determines the number of stop bits transmitted. The receiver checks for one stop bit only.
- 0 = One stop bit.
  - 1 = Two stop bits.

### 9.3.2 Control Register (SCICTL)

The SCICTL register controls the RX/TX enable, TXWAKE and SLEEP functions, internal clock enable, and the SCI software Reset.

SCI Control Register (SCICTL)  
[Memory – 1051h]

BIT#-	7	6	5	4	3	2	1	0
P051	—	—	SCI SW RESET	CLOCK	TXWAKE	SLEEP	TXENA	RXENA
			RW-0	RW-0	RS-0	RW-0	RW-0	RW-0

R=Read, W=Write, S=Set only, –n= Value after reset

- Bit 0 - **RXENA.** SCI Receive Enable.  
When this bit is set, received characters are transferred into RXBUF and the RXRDY flag is set. When cleared, this bit prevents received characters from being transferred into the receiver buffer (RXBUF); and no receiver interrupts are generated. However, the receiver shift register continues to assemble characters. Thus, if RXENA is set during the reception of a character, the complete character is transferred into RXBUF.  
0 = SCI Receiver disabled.  
1 = SCI Receiver enabled.
- Bit 1 - **TXENA.** SCI Transmit Enable.  
Data transmission through the SCITXD pin occurs only when this bit is set. If this bit is reset, the transmission is not halted until all the data previously written to TXBUF has been sent.  
0 = SCI Transmitter disabled.  
1 = SCI Transmitter enable.
- Bit 2 - **SLEEP.** SCI Sleep.  
This bit controls the receive features of the multiprocessor communication modes. This bit must be cleared by the user to bring the SCI out of Sleep mode.  
0 = Sleep mode disabled.  
1 = Sleep mode enabled.
- Bit 3 - **TXWAKE.** SCI Transmitter Wake-up.  
The TXWAKE bit controls the transmit features of the multiprocessor communication modes. This bit is cleared only by System reset. The SCI hardware clears this bit once it has been transferred to Wake Up Temporary (WUT).
- Bit 4 - **CLOCK.** SCI Internal Clock Enable.  
This bit determines the source of the SCICLK. Clearing this bit selects an external SCICLK, which is input on the high impedance SCICLK line and bypasses the baud rate generator. For Isosynchronous transactions, one bit is transmitted or received per SCICLK period. For Asynchronous transactions, one bit is transmitted or received per 16 SCICLK periods. The maximum frequency for the externally sourced SCICLK is CLKIN/16. Setting this bit selects an internal SCICLK, derived from the baud rate generator. This signal can be output on the SCICLK line.  
0 = External SCICLK.  
1 = Internal SCICLK.



Bit 5 - **SCI SW RESET.** SCI Software Reset (Active Low). Writing a 0 to this bit initializes the SCI state machines and operating flags to the reset condition. The CLOCK bit retains its state prior to the assertion of SCI SW RESET. If SCICLK is configured as an output, then the SCICLK resets (low level). All effected logic is held in the reset state until a 1 is written to the SCI SW RESET bit. Thus, after a system reset, the SCI must be reenabled by writing a 1 to this bit. This bit must be cleared after a receiver break detect.

SCI SW reset affects the operating flags of the SCI. This bit does not affect the configuration bits nor does it put in the reset values. The flags listed in Table 9–5 are set to the values shown when SCI SW RST is cleared. The operating flags are frozen until the SCI SW RST bit is set again.

**Table 9–5. Flags Affected by SCI SW RST**

SCI Flag	Value after SCI SW RST
TXRDY	1
TXEMPTY	1
RXWAKE	0
PE	0
OE	0
FE	0
BRKDT	0
RXRDY	0
RXERROR	0

**Note:**

The SCI SW RESET bit must be cleared before the SCI configuration registers can be set up or altered. All configuration registers should be set up by the application program prior to setting SCI SW RESET.

Bits 6,7 - Reserved. Read data is indeterminate.

### 9.3.3 Baud Select Registers (BAUD MSB and BAUD LSB)

The BAUD MSB and BAUD LSB registers store the data required to generate the baud rate. The SCI uses the combined 16-bit value, BAUD RATE REG, of the baud select registers to set the SCI clock frequency as follows:

$$\text{SCICLK frequency} = \text{CLKIN} / [(\text{BAUD RATE REG} + 1) \times 8].$$

where,

BAUD RATE REG = The 16 bit value in the Baud Rate Select Registers.

For example, if the CLKIN frequency is 20 MHz, then the maximum internal SCICLK frequency would be [20 MHz / 8], or 2.5 MHz.

For Asynchronous mode communication, data is transmitted and received at the rate of one bit for each 16 SCICLK periods. For Isosynchronous mode communication, data is transmitted and received at the rate of one bit for each SCICLK period. The Asynchronous and Isosynchronous Baud Rates are calculated as follows:

$$\text{Asynchronous Baud Rate} = \text{CLKIN} / [(\text{BAUD RATE REG} + 1) \times 128]$$

$$\text{Isosynchronous Baud Rate} = \text{CLKIN} / [(\text{BAUD RATE REG} + 1) \times 8]$$

**Baud Rate Select MSB Register (BAUD MSB)**  
[Memory address – 1052h]

BIT#-	7	6	5	4	3	2	1	0
P052	BAUDF (msb)	BAUDE	BAUDD	BAUDC	BAUDB	BAUDA	BAUD9	BAUD8
	RW-0	RW-0	RW-0	RW-0	RW-0	RW-0	RW-0	RW-0

**Baud Rate Select LSB Register (BAUD LSB)**  
[Memory address – 1053h]

BIT#-	7	6	5	4	3	2	1	0
P053	BAUD7	BAUD6	BAUD5	BAUD4	BAUD3	BAUD2	BAUD1	BAUD0 (lsb)
	RW-0	RW-0	RW-0	RW-0	RW-0	RW-0	RW-0	RW-0

R=Read, W=Write, -n= Value after reset

9

### 9.3.4 Transmitter Interrupt Control and Status Register (TXCTL)

The TXCTL Register contains the Transmitter Interrupt Enable, the Transmitter Ready flag, and the Transmitter Empty flag. The status flags are updated each time a complete character is transmitted. A summary of the register functions and bit assignments is shown below.

**Transmitter Interrupt Control and Status Register (TXCTL)**  
**[Memory address – 1054h]**

BIT#-	7	6	5	4	3	2	1	0
P054	TXRDY	TX EMPTY	—	—	—	—	—	SCI TX INT ENA
	R-1	R-1						RW-0

R=Read, W=Write, -n= Value after reset

- Bit 0 -     **SCI TX INT ENA.**  
 SCI Transmitter Ready Interrupt Enable. This bit controls the ability of the TXRDY bit to request an interrupt, but does not prevent the TXRDY bit from being set. The SCI TX INT ENA bit is set to 0 by a system reset.  
 0 = SCI TXRDY interrupt disabled.  
 1 = SCI TXRDY interrupt enabled.
  
- Bits 1–5 -   Reserved. Read data is indeterminate.
  
- Bit 6 -     **TX EMPTY.**  
 SCI Transmitter Empty. This bit indicates the status of the transmitter-shift register and the TXBUF register. TX EMPTY is set to 1 by a SCI SW RESET or a system reset.  
 0 = the CPU has written data to the TXBUF register, the data has not been completely transmitted.  
 1 = TXBUF and TXSHF register empty.
  
- Bit 7 -     **TXRDY.** SCI Transmitter Ready.  
 The TXRDY bit is set by the transmitter to indicate that TXBUF is ready to receive another character. The bit is automatically cleared when a character is loaded into TXBUF. This flag asserts a transmitter interrupt if the interrupt enable bit SCI TX INT ENA (TXCTL.0) is set. TXRDY is a read-only flag. It is set to 1 by an SCI SW RESET or a system reset.  
 0 = TXBUF is full.  
 1 = TXBUF is ready to receive character.

### 9.3.5 Receiver Interrupt Control and Status Register (RXCTL)

The RXCTL register contains one interrupt enable bit and seven receiver status flags (two of which can generate interrupt requests). The status flags are updated each time a complete character is transferred to the RXBUF. They are cleared each time RXBUF is read.

**SCI Receiver Interrupt Control and Status Register (RXCTL)**  
[Memory address – 1055h]

BIT#-	7	6	5	4	3	2	1	0
P055	RX ERROR	RXRDY	BRKDT	FE	OE	PE	RXWAKE	SCI RX INT ENA
	R-0	R-0	R-0	R-0	R-0	R-0	R-0	RW-0

R=Read, W=Write, -n= Value after reset

- Bit 0 - **SCI RX INT ENA.** SCI Receiver Interrupt Enable.  
The SCI RX INT ENA bit controls the ability of the RXRDY and the BRKDT bits to request an interrupt, but does not prevent these flags from being set.  
  
0 = RXRDY/BRKDT interrupt disabled.  
1 = RXRDY/BRKDT interrupt enabled.
- Bit 1 - **RXWAKE.** Receiver Wakeup Detect.  
The SCI sets this bit when a receiver wake-up condition is detected. In the Address Bit multiprocessor mode, RXWAKE reflects the value of the address bit for the character contained in RXBUF. In the Idle line multiprocessor mode RXWAKE is set if an idle SCIRXD line is detected. RXWAKE is a read-only flag. It is cleared by transfer of the first byte after the address byte to RXBUF, by reading the address character in RXBUF, by an SCI SW RESET, or by a system reset. See Section 9.2.5.
- Bit 2 - **PE.** SCI Parity Error Flag.  
This flag bit is set when a character is received with a mismatch between the number of 1s and its parity bit. The parity checker includes the address bit in the calculation. If Parity generation and detection is not enabled, the PE flag is disabled and read as 0. The PE bit is reset by an SCI SW RESET, a system reset, or by reading RXBUF.  
  
0 = No Parity error or Parity is disabled.  
1 = Parity error detected.
- Bit 3 - **OE.** SCI Overrun Error Flag.  
The SCI sets this bit when a character is transferred into RXBUF before the previous character has been read out. The previous character is overwritten and lost. The OE flag is reset by an SCI SW RESET, a system reset, or reading RXBUF.  
  
0 = No Overrun error detected.  
1 = Overrun error detected.
- Bit 4 - **FE.** SCI Framing Error Flag.  
The SCI sets this bit when a stop bit is not found when expected. Only the first stop bit is checked. The missing stop bit indicates that synchronization with the start bit has been lost and the character is incorrectly framed. It is reset by an SCI SW RESET, a system reset, or by reading RXBUF.  
  
0 = No Framing error detected.  
1 = Framing error detected.

- Bit 5 - **BRKDT.** SCI Break Detect Flag.  
The SCI sets this bit when a break condition occurs. A break condition occurs when the SCIRXD line remains continuously low for at least 10 bits beginning after a missing first stop bit. The occurrence of a break causes a receiver interrupt to be generated if the SCI RX INT ENA bit is a 1, but it does not cause the receiver buffer to be loaded. A BRKDT interrupt can occur even if the receiver SLEEP bit is set to 1. BRKDT is cleared by an SCI SW reset or by a system reset. It is not cleared by receipt of a character after the break is detected. The SCI must be reset through toggling the SCI SW RST bit or by a system reset in order to receive more characters.
- Bit 6 - **RXRDY.** SCI Receiver Ready.  
The receiver sets this bit to indicate that RXBUF is ready with a new character, and clears the bit when the character is read. A receiver interrupt is generated if the SCI RX INT ENA bit is a 1. RXRDY is reset by an SCI SW reset or a system reset.
- Bit 7 - **RX ERROR.** SCI Receiver Error Flag.  
The RX ERROR Flag indicates that one of the error flags in the receiver status register is set. It is a logical "or" of the parity, overrun, framing error, and break detect flags. The bit can be used for fast error condition checking during the interrupt service routine since a negative value of the status register indicates that an error condition has occurred. This error flag cannot be cleared directly, but is cleared if no individual error flags are set. This bit is cleared by an SCI SW reset, a system reset, or reading RXBUF.

### 9.3.6 Receiver Data Buffer Register (RXBUF)

The RXBUF register contains current data from the receiver shift register. RXBUF is cleared by system reset.

**Receiver Data Buffer Register (RXBUF)**  
[Memory address – 1057h]

BIT#-	7	6	5	4	3	2	1	0
P057	RXDT7	RXDT6	RXDT5	RXDT4	RXDT3	RXDT2	RXDT1	RXDT0
	R-0	R-0	R-0	R-0	R-0	R-0	R-0	R-0

R=Read, -n= Value after reset

### 9.3.7 Transmit Data Buffer Register (TXBUF)

The TXBUF register is a read/write register used to store data bits to be transmitted by SCITX. Data written to TXBUF must be right justified because the left-most bits are ignored for characters less than eight bits long.

**Transmit Data Buffer Register (TXBUF)**  
[Memory address – 1059h]

BIT#-	7	6	5	4	3	2	1	0
P059	TXDT7	TXDT6	TXDT5	TXDT4	TXDT3	TXDT2	TXDT1	TXDT0
	RW-0	RW-0	RW-0	RW-0	RW-0	RW-0	RW-0	RW-0

R=Read, W=Write, -n= Value after reset

### 9.3.8 Port Control Register 1 (SCIPC1)

The SCIPC1 register controls the SCICLK pin functions.

**SCI Port Control Register 1 (SCIPC1)**  
**[Memory address – 105D]**

BIT#-	7	6	5	4	3	2	1	0
P05D	—	—	—	—	SCICLK DATA IN	SCICLK DATA OUT	SCICLK FUNC- TION	SCICLK DATA DIR
					R-0	RW-0	RW-0	RW-0

R=Read, W=Write, –n= Value after reset

- Bit 0 - **SCICLK DATA DIR.** SCICLK Data Direction.  
 This bit determines the data direction on the SCICLK pin if SCICLK has been configured as a general purpose I/O pin.  
 0 = SCICLK pin is a general purpose INPUT pin.  
 1 = SCICLK pin is a general purpose OUTPUT pin.
- Bit 1 - **SCICLK FUNCTION.**  
 This bit defines the function of the SCICLK pin.  
 0 = SCICLK pin is a general purpose digital I/O pin.  
 1 = SCICLK pin is the SCI serial clock pin.
- Bit 2 - **SCICLK DATA OUT**  
 This bit contains the data to be output on the SCICLK pin if the following conditions are met:  
 a. SCICLK pin is configured as general purpose I/O.  
 b. SCICLK pin data direction is defined as output.
- Bit 3 - **SCICLK DATA IN**  
 The SCICLK DATA IN bit contains the current value on the SCICLK pin.
- Bits 4–7 - Reserved. Read data is indeterminate.

### 9.3.9 Port Control Register 2 (SCIPC2)

The SCIPC2 register controls the SCIRXD and SCITXD pin functions.

**SCI Port Control Register 2 (SCIPC2)**  
**[Memory address – 105E]**

BIT#-	7	6	5	4	3	2	1	0
P05E	SCITXD DATA IN	SCITXD DATA OUT	SCITXD FUNC- TION	SCITXD DATA DIR	SCIRXD DATA IN	SCIRXD DATA OUT	SCIRXD FUNC- TION	SCIRXD DATA DIR
	R-0	RW-0	RW-0	RW-0	R-0	RW-0	RW-0	RW-0

R=Read, W=Write, -n= Value after reset

- Bit 0 - **SCIRXD DATA DIR.** SCIRXD Data Direction  
 This bit determines the data direction on the SCIRXD pin if SCIRXD has been defined as a general purpose I/O pin.  
 0 = SCIRXD pin is a general purpose INPUT pin.  
 1 = SCIRXD pin is a general purpose OUTPUT pin.
- Bit 1 - **SCIRXD FUNCTION**  
 This bit defines the function of the SCIRXD pin.  
 0 = SCIRXD pin is a general purpose digital I/O pin.  
 1 = SCIRXD pin is the SCI Receiver pin.
- Bit 2 - **SCIRXD DATA OUT**  
 This bit contains the data to be output on the SCIRXD pin if the following conditions are met:  
 a. SCIRXD pin has been defined as a general purpose I/O pin.  
 b. SCIRXD pin data direction has been defined as output.
- Bit 3 - **SCIRXD DATA IN**  
 This bit contains the current value on the SCIRXD pin.
- Bit 4 - **SCITXD DATA DIR.** SCITXD Data Direction.  
 This bit determines the data direction on the SCITXD pin if SCITXD has been defined as a general purpose I/O pin.  
 0 = SCITXD pin is a general purpose INPUT pin.  
 1 = SCITXD pin is a general purpose OUTPUT pin.
- Bit 5 - **SCITXD FUNCTION**  
 This bit defines the function of the SCITXD pin.  
 0 = SCITXD pin is a general purpose digital I/O pin.  
 1 = SCITXD pin is the SCI Transmit pin.
- Bit 6 - **SCITXD DATA OUT**  
 This bit contains the data to be output on the SCITXD pin if the following conditions are met:  
 a. SCITXD pin data direction is defined as output.  
 b. SCITXD pin is configured as general purpose I/O.
- Bit 7 - **SCITXD DATA IN**  
 This bit contains the current value on the SCITXD pin.



### 9.3.10 Priority Control Register (SCIPRI)

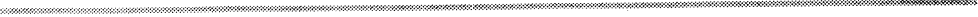
The SCIPRI register contains the Receiver and Transmitter Interrupt Priority Select bits. This register is read-only during normal operation, but can be written to in the privileged mode.

**SCI Priority Control Register (SCIPRI)**  
**[Memory address – 105F]**

BIT#-	7	6	5	4	3	2	1	0
P05F	SCI STEST	SCITX PRIOR- ITY	SCIRX PRIOR- ITY	SCI ESPEN	—	—	—	—
	RP-0	RP-0	RP-0	RP-0				

R=Read, P=Privileged State write only, –n= Value after reset

- Bits 0–3 - Reserved. Read values are indeterminate.
- Bit 4 - **SCI ESPEN.** SCI Emulator Suspend Enable.  
 This bit has no effect except when using the XDS emulator to debug a program. Then, this bit determines how the SCI operates when the program is suspended by an action such as a hardware or software breakpoint.  
 0 = When the emulator is suspended, the SCI continues to work until the current transmit or receive sequence is complete.  
 1 = When the emulator is suspended, the SCI state machine is frozen so that the state of the SCI can be examined at the point that the emulator was suspended.
- Bit 5 - **SCI RX PRIORITY.** SCI Receiver Interrupt Priority Select.  
 This bit assigns the interrupt priority level of the SCI receiver interrupts.  
 0 = Receiver Interrupts are Level 1 (high priority) requests.  
 1 = Receiver Interrupts are Level 2 (low priority) requests.
- Bit 6 - **SCI TX PRIORITY.** SCI Transmitter Interrupt Priority Select.  
 This bit assigns the interrupt priority level of the SCI transmitter interrupts.  
 0 = Transmitter Interrupts are Level 1 (high priority) requests.  
 1 = Transmitter Interrupts are Level 2 (low priority) requests.
- Bit 7 - **SCI STEST.**  
 This bit must be cleared to ensure proper operation.



9

Introduction	1
Assembly Language Instruction Set	13
TMS370 Family Devices	2
Design Aids	14
CPU and Memory Organization	3
Development Support	15
System and Digital I/O Configuration	4
Electrical Specifications	16
Interrupts and System Reset	5
Customer Information	17
EEPROM Modules	6
Appendices	A-H
Timer 1 Module	7
Timer 2 Module	8
Serial Communications Interface (SCI) Port	9
Serial Peripheral Interface (SPI) Module	10
Analog-to-Digital Converter Module	11
TMS370 Programmable Acquisition and Control Timer	12



# Serial Peripheral Interface (SPI) Module

---

---

---

This chapter discusses the architecture and programming of the Serial Peripheral Interface module of the TMS370 family and covers the following topics:

<b>Section</b>	<b>Page</b>
10.1 Serial Peripheral Interface Module Overview .....	10-2
10.2 SPI Operation .....	10-5
10.3 SPI Control Registers .....	10-11

## 10.1 Serial Peripheral Interface (SPI) Module Overview

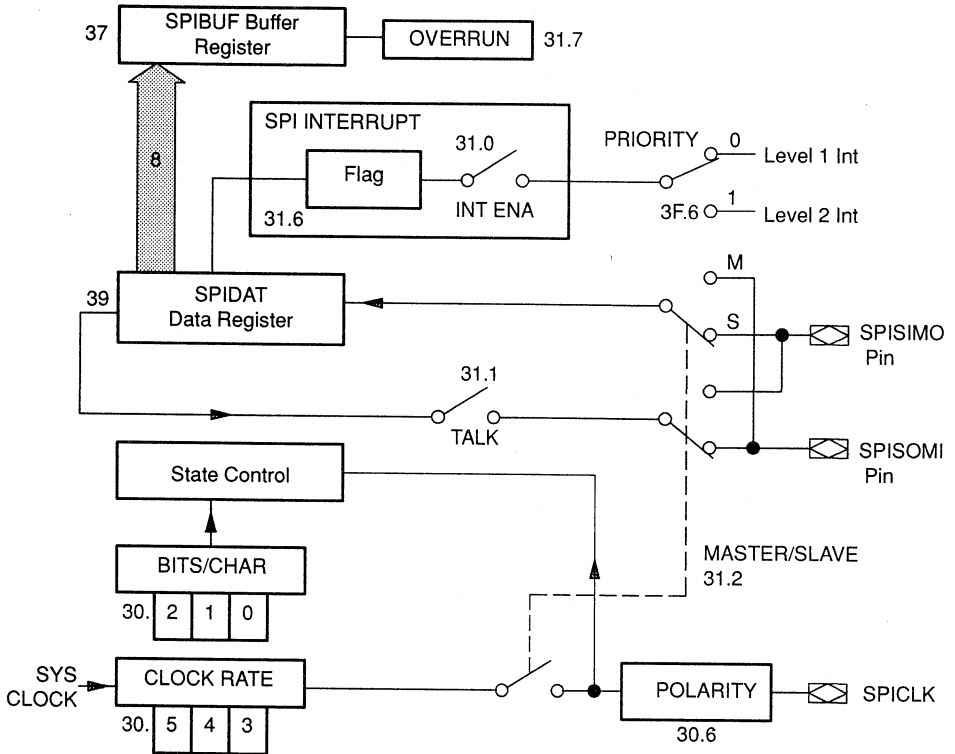
The SPI module is a high-speed synchronous serial I/O port that allows a serial bit stream of programmed length (one to eight bits) to be shifted into and out of the device at a programmed bit transfer rate. The SPI is normally used for communications between the microcontroller and external peripherals or another microcontroller. Typical applications include external I/O or peripheral expansion using devices such as shift registers, display drivers, A/D converters, etc. Multiprocessor communications are also supported by the master/slave operation of the SPI.

### 10.1.1 Physical Description

The SPI module, as shown in Figure 10–1, consists of:

- Three I/O pins:
  - SPISIMO – SPI Slave In, Master Out.
  - SPISOMI – SPI Slave Out, Master In
  - SPICLK – SPI CLOCK
- SPIBUF – SPI Buffer register
- SPIDAT – SPI Data Shift register
- State Control logic
- SPI Control registers located at P030 – P03F

Figure 10–1. SPI Block Diagram



### 10.1.2 SPI Control Registers

The SPI control registers occupy Peripheral File Frame 3 as shown in Figure 10–2.

**Table 10–1. SPI Memory Map**

Peripheral File Location	Symbol	Name
P030	SPICCR	SPI Configuration Control Register
P031	SPICTL	SPI Control Register
P032 - P036		Reserved
P037	SPIBUF	Receive Data Buffer Register
P038		Reserved
P039	SPIDAT	Serial Data Register
P03A - P03C		Reserved
P03D	SPIPC1	SPI Pin Control 1
P03E	SPIPC2	SPI Pin Control 2
P03F	SPIPRI	SPI Priority Control



## 10.2 SPI Operation

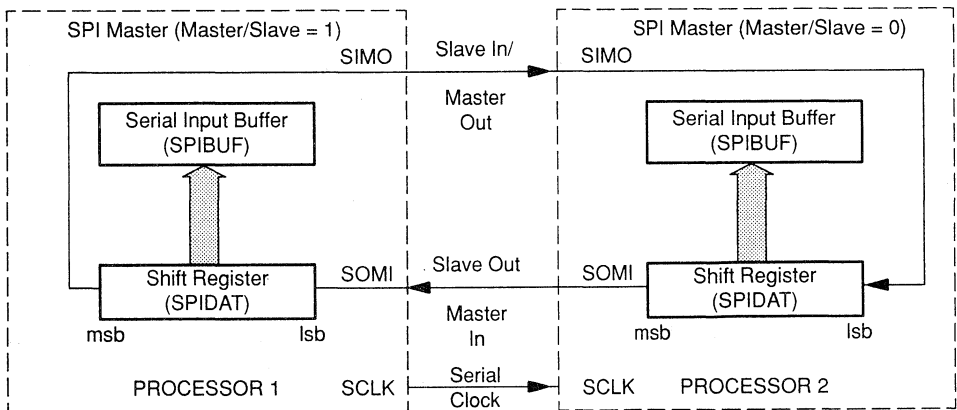
Figure 10–2 shows a typical connection of the SPI for communications between two microcontrollers. One controller, the master, initiates data transfer by sending the SPICLK signal. Data is shifted out of both shift registers on one edge of the clock and latched into both shift registers on the opposite clock edge. Thus both controllers send and receive data at the same time. Whether or not the data is meaningful or dummy data depends on the application software.

There are three possible cases for data transmission:

- Master sends data and Slave sends dummy data
- Master sends data and Slave sends data
- Master sends dummy data and Slave sends data

The Master can initiate data transfer at any time because it controls the SPICLK. The manner in which the Master knows when the Slave wishes to broadcast data is determined by the software protocol.

**Figure 10–2. SPI Master/Slave Connection**



### 10.2.1 SPI Data Format

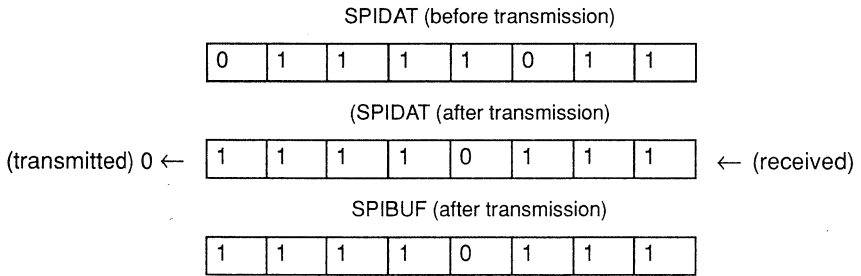
Three character-length bits (SPICCR.2–0) specify the number of bits in the data character (1 - 8 bits). This information directs the state control logic to count the number of bits received or transmitted to determine when a complete character has been processed.

For characters with fewer than 8 bits:

- 1) Data must be written to SPIDAT left justified.
- 2) Data must be read back from SPIBUF right justified.
- 3) SPIBUF contains the most recently received character, right justified, plus any bits left over from previous transmission(s) which have been shifted to the msb position.

For example:

If the character length = 1 bit, and  
the value written into SPIDAT = 07Fh,  
then;



### 10.2.2 SPI Interrupts

The interrupt for the SPI is controlled by bits in two registers. The SPI INT ENA bit (SPICTL.0), when set, allows assertion of an interrupt request when an interrupt condition occurs. The SPI PRIORITY bit (SPIPRI.6) determines whether SPI interrupts are level 1 or level 2 priority requests.

When a complete character has been shifted into or out of the SPIBUF register, the SPI Interrupt Flag is set and an interrupt is generated if enabled by SPI INT ENA (SPICTL.0). The interrupt flag remains set until cleared by one of the following four events:

- ❑ The CPU reads the SPI receiver buffer (SPIBUF),
- ❑ The CPU enters the Halt or Standby mode with an IDLE instruction,
- ❑ Software sets the SPI SW RESET bit, or
- ❑ A System resets occurs.

An interrupt request must be explicitly cleared by one of the four methods listed above to avoid generating another interrupt. An interrupt request can be temporarily disabled by clearing the SPI INT ENA bit. However, unless the SPI INT FLAG itself is cleared, the interrupt request will be reasserted when the enable bit is again set to 1.

The priority level of the SPI interrupt is specified by the SPI PRIORITY bit (SPIPRI.6). If SPI PRIORITY = 0, then a level 1 priority interrupt is generated. If SPI PRIORITY = 1, then a level 2 priority interrupt is generated.

When the SPI INT FLAG bit is set, a character has been placed into the SPIBUF register and is ready to be read. If the CPU does not read the character by the time the next complete character has been received, the new character is written into the SPIBUF and the RECEIVER OVERRUN bit (SPICTL.7) is set. This indicates that the last character of data has been over-written with new data before the previous character could be read.

### 10.2.3 SPI Clock Sources

The CLOCK POLARITY bit (SPICCR.6), selects the active edge of the clock, either rising or falling.

In the slave mode, the SPI clock is received from an external source and can be no greater than the CLKIN frequency divided by 32.

In the master mode, the SPI clock is generated by the SPI and is output on the SPICLK pin.

The SPI BIT RATE0—2 bits (SPICCR.5—3) determine the bit transfer rate for sending and receiving the data. This transfer rate is defined by:

$$\text{SPI BAUD RATE} = \text{CLKIN} / (8 \times 2^b)$$

where b=bit rate in SPICCR.5–3 (range 0–7).

Table 10–2 shows the baud rates for common crystal frequencies versus the SPI bit rate values.

**Table 10–2. Common SPI Bit Rates**

Crystal/Oscillator Frequency (MHz)						
SPI Value	Divide by	20 MHz	12 MHz	10 MHz	5 MHz	2 MHz
0	8	2500	1500	1250	625	250
1	16	1250	750	625	312.5	125
2	32	625	375	312.5	156.25	62.5
3	64	312.5	187.5	156.25	78.125	31.25
4	128	156.25	93.75	78.125	39.0625	15.625
5	256	78.125	46.875	39.0625	19.53125	7.8125
6	512	39.0625	23.4375	19.53125	9.765625	3.90625
7	1024	19.53125	11.71875	9.765625	4.882813	1.953125

**Note:** Bit rates are in Kbits/sec.

## 10.2.4 SPI Operation Modes

The MASTER/SLAVE bit (SPICTL.2) selects the operating mode and the source of SPICLK. The SPI module may operate as a Master or Slave.

### 10.2.4.1 Master

In the Master mode (MASTER/SLAVE = 1), the SPI provides the serial clock on the SPICLK pin for the entire serial communications network. Data is output on the SPISIMO pin on the first SPICLK edge and latched from the SPISOMI pin on the opposite edge of SPICLK.

The SPICCR register (SPI BIT RATE0–2) determines the bit transfer rate for the network, both transmit and receive. There are eight data transfer rates that can be selected by these control bits as shown in Table 10–2.

Data written to the SPIDAT register initiates data transmission on the SPISIMO pin, msb first. Simultaneously, received data is shifted in the SPISOMI pin into the SPIDAT register, and upon completion of transmitting the selected number of bits, the data is transferred to the SPIBUF (double buffered receiver) for reading by the CPU to permit new transactions to take place. Data is shifted into the SPI most significant bit first. It is stored right-justified in SPIBUF.

To receive a character when operating as a master, data must be written to the SPIDAT to initiate the transaction. When the specified number of data bits have been shifted through the SPIDAT register, the following events occur:

- 1) The SPI INT FLAG bit is set,
- 2) SPIDAT contents transfer to SPIBUF, and
- 3) If the SPI INT ENA bit is set to one, an interrupt is asserted.

Writing to the SPIDAT register before transmission is complete corrupts the current transmission.

### 10.2.4.2 Slave

In the slave mode (MASTER/SLAVE = 0), data shifts out on the SPISOMI pin and in on the SPISIMO pin. The SPICLK pin is used as the input for the serial shift clock, which is supplied from the external network master. The transfer rate is defined by this clock. The SPICLK input frequency should be no greater than CLKIN frequency divided by 32.

Data written to the SPIDAT register is transmitted to the network when the SPICLK is received from the network master. To receive data, the SPI waits for the network master to send SPICLK and then shifts the data on the SPISIMO pin into the SPIDAT register. If data is to be transmitted by the slave simultaneously, then it must be written to the SPIDAT register prior to the beginning of SPICLK.

---

When the TALK bit (SPICTL.1) is cleared, data transmission is disabled and the output line is put into a high impedance state. This allows many slave devices to be tied together on the network, but only one slave is allowed to talk at a time.

### 10.2.5 Initialization

A system reset forces the SPI peripheral module into the following default configuration:

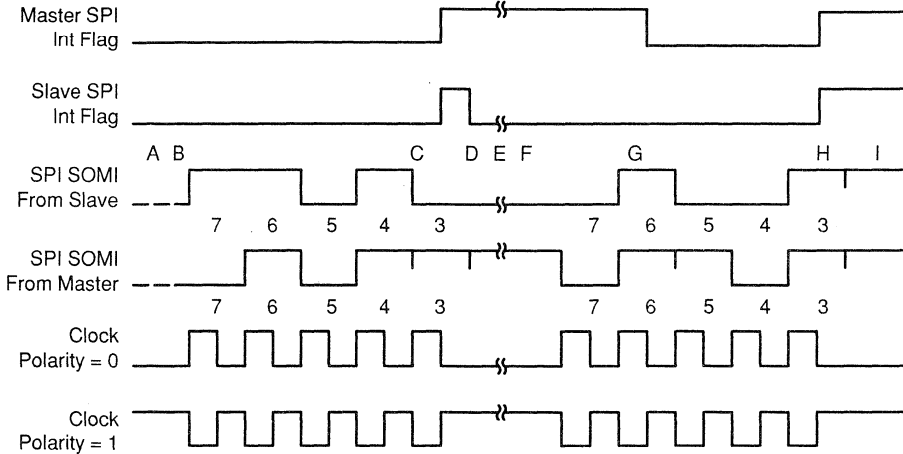
- The unit is configured as a slave module (MASTER/SLAVE = 0).
- The transmit capability is disabled (TALK = 0).
- Data is latched at the input on the falling edge of SPICLK.
- Character length is assumed to be 1 bit.
- The SPI interrupts are disabled.
- Data in the SPI Data Register is 00h.

To change this SPI configuration it is a good idea to use the SPI SW RESET bit. Set the SPI SW RST bit (SPICCR.7); make your desired changes; then clear the SPI SW RST bit. This prevents unwanted and unforeseen events from occurring during or as a result of mode change.

### 10.2.6 SPI Example

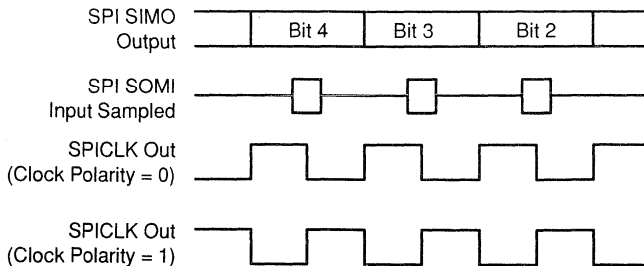
The following timing diagrams illustrate an example SPI data transfer between two TMS370 devices using a character length of five bits. The lettered notes following the first diagram are keyed to the letter labels in the diagram.

#### 5 BITS PER CHARACTER



- A. Slave writes 0D0h to SPIDAT and waits for the master to shift out the data.
- B. Master writes 058h to SPIDAT which starts the transmission procedure.
- C. First byte is finished and sets the interrupt flags.
- D. Slave reads 0Bh from its SPIBUF register (right justified).
- E. Slave writes 04Ch to SPIDAT and waits for the master to shift out the data.
- F. Master writes 06Ch to SPIDAT which starts the transmission procedure.
- G. Master reads 01Ah from the SPIBUF register (right justified).
- H. Second byte is finished and set the interrupt flags.
- I. Master received 09h and the Slave received a 0Dh (right justified).

#### SIGNALS CONNECTING TO MASTER PROCESSOR



### 10.3 SPI Control Registers

The SPI is controlled and accessed through registers in the Peripheral File. These registers are listed in Figure 10–3 and described in the following sections. The bits shown in shaded boxes in Figure 10–3 are Privilege Mode bits, that is, they can only be written to in the Privilege Mode.

**Figure 10–3. SPI Control Registers**

ADDR	PF	7	6	5	4	3	2	1	0	
1030h	P030	SPI SW RESET	CLOCK POLARITY	SPI BIT RATE2	SPI BIT RATE1	SPI BIT RATE0	SPI CHAR2	SPI CHAR1	SPI CHAR0	SPICCR
1031h	P031	RECEIVER OVERRUN	SPI INT FLAG	—	—	—	MASTER / SLAVE	TALK	SPI INT ENA	SPICTL
1032h	P032	RESERVED								
to	to									
1036h	P036									
1037h	P037	RCVD7	RCVD6	RCVD5	RCVD4	RCVD3	RCVD2	RCVD1	RCVD0	SPIBUF
1038h	P038	RESERVED								
1039h	P039	SDAT7	SDAT6	SDAT5	SDAT4	SDAT3	SDAT2	SDAT1	SDAT0	SPIDAT
103Ah	P03A	RESERVED								
to	to									
103Ch	P03C									
103Dh	P03D	—	—	—	—	SPICLK DATA IN	SPICLK DATA OUT	SPICLK FUNCTION	SPICLK DATA DIR	SPIPC1
103Eh	P03E	SPISIMO DATA IN	SPISIMO DATA OUT	SPISIMO FUNCTION	SPISIMO DATA DIR	SPISIMO DATA IN	SPISIMO DATA OUT	SPISIMO FUNCTION	SPISIMO DATA DIR	SPIPC2
103Fh	P03F	SPI STEST	SPI PRIORITY	SPI ESPEN	—	—	—	—	—	SPIPRI

### 10.3.1 SPI Configuration Control Register

The SPICCR register controls the setup of the SPI for operation. A summary of the register functions and bit assignments is shown below.

**SPI Configuration Control Register (SPICCR)**  
**[Memory Address – 1030h]**

BIT#-	7	6	5	4	3	2	1	0
P030	SPI SW RESET	CLOCK POLARITY	SPI BIT RATE2	SPI BIT RATE1	SPI BIT RATE0	SPI CHAR2	SPI CHAR1	SPI CHAR0
	RW-0	RW-0	RW-0	RW-0	RW-0	RW-0	RW-0	RW-0

R=Read, W=Write, -n= Value after reset

Bits 0–2 -

**CHAR0—2.** Character Length Control Bits 0—2.

These three bits determine the number of bits to be shifted in or out as a single character during one shift sequence. The value of these bits is represented in the following table.

**Table 10–3. SPI Character Bit Length**

CHAR2	CHAR1	CHAR0	Character Length
0	0	0	1
0	0	1	2
0	1	0	3
0	1	1	4
1	0	0	5
1	0	1	6
1	1	0	7
1	1	1	8



Bits 3–5 - **SPI BIT RATE0—2.** SPI Bit Rate Control Bits 0—2.  
 These bits determine the bit transfer rate if the SPI is the network master. There are eight data transfer rates (each a function of the system clock) that can be selected. The system clock is divided by an eight bit, free-running prescaler from which eight taps are available for use as the shift clock. One data bit is shifted per SPICLK cycle.

**Table 10–4. SPI Clock Frequency**

SPI † Bit Rate2	SPI † Bit Rate1	SPI † Bit Rate0	SPI Clock Frequency
0	0	0	CLKIN/8
0	0	1	CLKIN/16
0	1	0	CLKIN/32
0	1	1	CLKIN/64
1	0	0	CLKIN/128
1	0	1	CLKIN/256
1	1	0	CLKIN/512
1	1	1	CLKIN/1024

† If the SPI is a network slave, the module receives a clock on the SPICLK pin from the network master; and these bits have no effect on SPICLK. The frequency of the input clock should be no greater than the CLKIN frequency divided by 32.

Bit 6 - **CLOCK POLARITY.** Shift Clock Polarity.  
 The CLOCK POLARITY bit controls the polarity of the SPICLK signal.

0 = The inactive level is low; data is output by the rising edge of SPICLK; input data is latched by the falling edge of SPICLK.

1 = The inactive level is high; data is output by the falling edge of SPICLK; input data is latched by the rising edge of SPICLK.

Bit 7 – **SPI SW RESET.** SPI Software Reset.  
 Writing a 1 to this bit initializes the SPI circuitry and operating flags to the reset condition. Specifically, the RECEIVER OVERRUN and SPI INT FLAG flags are cleared. The SPI configuration remains unchanged. If it is operating as a master, the SPICLK output level returns to its inactive level.

When a 0 is written to SPI SW RESET the SPI is ready to transmit or receive the next character. A character written to the transmitter when SPI SW RESET is a 1 will not be shifted out when SPI SW RESET bit is cleared. A new character must be written to the Serial Data Register. To change any configuration bits, this bit should be used (see Section 10.2.5).

### 10.3.2 SPI Operation Control Register

The SPI Operation Control Register contains control and status bits as shown below.

**SPI Operation Control Register, (SPICTL)  
[Memory Address – 1031h]**

BIT#-	7	6	5	4	3	2	1	0
P031	<b>RECEIVER OVERRUN</b>	<b>SPI INT FLAG</b>	—	—	—	<b>MASTER/ SLAVE</b>	<b>TALK</b>	<b>SPI INT ENA</b>
	R-0	R-0				RW-0	RW-0	RW-0

R=Read, W=Write, -n= Value after reset

- Bit 0 - **SPI INT ENA.** SPI Interrupt Enable.  
 This bit controls the SPI's ability to generate an interrupt. The SPI INT FLAG is unaffected by this bit.  
 0 = disable interrupt.  
 1 = enable interrupt.
- Bit 1 - **TALK.** Master/Slave Transmit Enable.  
 This bit allows data transmission (master or slave) to be disabled by placing the serial data output in a high impedance state. TALK is cleared (disabled) by a system reset.  
 0 = Transmission disabled; if not programmed as a general purpose I/O pin, the SPI serial output is in a high impedance state.  
 1 = Transmission enabled.
- Bit 2 - **MASTER/SLAVE.** SPI Network Mode Control.  
 This bit determines whether the SPI is a network master or slave. During reset initialization, the SPI is automatically configured as a slave.  
 0 = SPI configured as a slave.  
 1 = SPI configured as a master
- Bits 3–5 - Reserved. Read data is indeterminate.
- Bit 6 - **SPI INT FLAG.** Serial Peripheral Interrupt Flag.  
 The SPI hardware sets this bit to indicate it has completed sending or receiving the last bit and is ready to be serviced. A character received is placed in the receiver buffer at the time the SPI INT FLAG bit is set. SPI INT FLAG is cleared when the receiver buffer is read. It is also cleared by an SPI software reset (SPI SW RESET) or by a system reset.
- Bit 7 - **RECEIVER OVERRUN.**  
 This bit is a read only flag which the SPI hardware sets when a receive or transmit operation completes before the previous character has been read from the receive buffer. It indicates that the last received character has been overwritten, and therefore has been lost. RECEIVER OVERRUN is cleared when the receiver buffer is read. It is also cleared by SPI SW RESET or a system reset.

### 10.3.3 Serial Input Buffer (SPIBUF)

The SPIBUF register contains the data received from the network ready for the CPU to read.

**Serial Input Buffer, (SPIBUF)**  
**[Memory Address – 1037h]**

BIT#-	7	6	5	4	3	2	1	0
P037	RCVD7 (msb)	RCVD6	RCVD5	RCVD4	RCVD3	RCVD2	RCVD1	RCVD0 (lsb)
	R-0	R-0	R-0	R-0	R-0	R-0	R-0	R-0

R=Read, -n= Value after reset

Once the Serial Data Register has received the complete character, the character is then transferred to the SPIBUF Register where it can be read. The SPI INT FLAG bit (SPICTL.6) is set to indicate that the data is available when the received character is transferred. Since data is shifted into the SPI most significant bit first, it is stored right justified in the SPIBUF.

### 10.3.4 Serial Data Register (SPIDAT)

The SPIDAT register is the transmit/receive shift register. Data written to the SPIDAT is shifted out on subsequent SPICLK cycles. For every bit shifted out of the SPI a bit is shifted into the other end of the shift register.

Writing to the SPIDAT performs two functions. First, it provides data to be output on the serial output pin if the TALK bit is set. Second, when the SPI is operating as a master, writing to this register initiates a transaction.

To initiate a receiver sequence, dummy data is written to the register. Since the data is not hardware justified for characters that are shorter than eight bits, transmit data must be written in left justified form and received data read in right justified form.

**Serial Data Register, (SPIDAT)**  
**[Memory Address – 1039h]**

BIT#-	7	6	5	4	3	2	1	0
P039	SDAT7	SDAT6	SDAT5	SDAT4	SDAT3	SDAT2	SDAT1	SDAT0
	RW-0	RW-0	RW-0	RW-0	RW-0	RW-0	RW-0	RW-0

R=Read, W=Write, -n= Value after reset

### 10.3.5 Port Control Registers

Two Port Control Registers (SPIPC1 and SPIPC2) allow a programmer to control all functions for a SPI port pin in one write cycle. Each module pin is controlled by a nibble in one of the SPIPC's.

#### 10.3.5.1 Port Control Register 1 (SPIPC1)

This register controls the SPICLK pin.

**Port Control Register 1, (SPIPC1)**  
[Memory Address – 103Dh]

BIT#-	7	6	5	4	3	2	1	0
P03D	—	—	—	—	SPICLK DATA IN	SPICLK DATA OUT	SPICLK FUNC- TION	SPICLK DATA DIR
					R-0	RW-0	RW-0	RW-0

R=Read, W=Write, —= Value after reset

- Bit 0 - **SPICLK DATA DIR.** SPICLK Data Direction.  
This bit determines the data direction on the SPICLK pin if SPICLK has been defined as a general purpose I/O pin.  
0 = SPICLK pin is a general purpose INPUT pin.  
1 = SPICLK pin is a general purpose OUTPUT pin.
- Bit 1 - **SPICLK FUNCTION.** SPICLK Pin Function Select.  
This bit defines the function of the SPICLK pin.  
0 = SPICLK pin is a general purpose digital I/O pin.  
1 = SPICLK pin contains the SPI clock.
- Bit 2 - **SPICLK DATA OUT.** SPICLK Port Data Out.  
This bit contains the data to be output on the SPICLK pin if the following conditions are met:  
a. SPICLK pin has been defined as a general purpose I/O pin.  
b. SPICLK pin data direction has been defined as output.
- Bit 3 - **SPICLK DATA IN.** SPICLK Pin Port Data In.  
This bit contains the current value on the SPICLK pin regardless of the mode. A write to this bit has no effect.
- Bits 4–7 - Reserved. Read data is indeterminate.

**Note:**

The SPICLK pin always functions as the SPICLK input pin in the slave mode (i.e., SPICLK.2=0) even if SPICLK FUNCTION = 0.

### 10.3.5.2 Port Control Register 2

The SPIPC2 register controls the SPISOMI and SPISIMO pin functions.

**Port Control Register 2, (SPIPC2)**  
**[Memory Address – 103Eh]**

BIT#-	7	6	5	4	3	2	1	0
P03E	SPISIMO DATA IN	SPISIMO DATA OUT	SPISIMO FUNCTION	SPISIMO DATA DIR	SPISOMI DATA IN	SPISOMI DATA OUT	SPISOMI FUNCTION	SPISOMI DATA DIR
	R-0	RW-0	RW-0	RW-0	R-0	RW-0	RW-0	RW-0

R=Read, W=Write, -n= Value after reset

- Bit 0 - SPISOMI DATA DIR.** SPISOMI Data Direction.  
 This bit determines the data direction on the SPISOMI pin if SPISOMI has been defined as a general purpose I/O pin.  
 0 = SPISOMI pin is a general purpose INPUT pin.  
 1 = SPISOMI pin is a general purpose OUTPUT pin.
- Bit 1 - SPISOMI FUNCTION.** SPISOMI Pin Function Select.  
 This bit defines the function of the SPISOMI pin. When SPISOMI is an input and SPISOMI FUNCTION and SPISOMI DATA DIR are disabled, then SPICLK still clocks the internal circuitry.  
 0 = SPISOMI pin is a general purpose digital I/O pin.  
 1 = SPISOMI pin contains the SPI data.
- Bit 2 - SPISOMI DATA OUT.** SPISOMI Pin Data Out.  
 This bit contains the data to be output on the SPISOMI pin if the following conditions are met:  
 a. SPISOMI pin has been defined as a general purpose I/O pin.  
 b. SPISOMI pin data direction has been defined as output.
- Bit 3 - SPISOMI DATA IN.** SPISOMI Pin Data In.  
 This bit contains the current value on the SPISOMI pin regardless of the mode. A write to this bit has no effect.
- Bit 4 - SPISIMO DATA DIR.** SPISIMO Data Direction.  
 This bit determines the data direction on the SPISIMO pin if SPISIMO has been defined as a general purpose I/O pin.  
 0 = SPISIMO pin is a general purpose INPUT pin.  
 1 = SPISIMO pin is a general purpose OUTPUT pin.
- Bit 5 - SPISIMO FUNCTION.** SPISIMO Pin Function Select.  
 This bit defines the function of the SPISIMO pin.  
 0 = SPISIMO pin is a general purpose digital I/O pin.  
 1 = SPISIMO pin contains the SPI data.
- Bit 6 - SPISIMO DATA OUT.** SPISIMO Pin Data Out.  
 This bit contains the data to be output on the SPISIMO pin if the following conditions are met:  
 a. SPISIMO pin has been defined as a general purpose I/O pin.  
 b. SPISIMO pin data direction has been defined as output.

Bit 7 -

**SPISIMO DATA IN.** SPISIMO Pin Data In.

This bit contains the current value on the SPISIMO pin regardless of the mode. A write to this bit has no effect.

### 10.3.6 SPI Interrupt Priority Control Register (SPIPRI)

The SPIPRI Register selects the interrupt priority level of the SPI interrupt. The register is read only during normal operation, but can be written to in the privileged mode.

**SPI Interrupt Priority Control Register, (SPIPRI)**  
[Memory Address – 103Fh]

BIT#-	7	6	5	4	3	2	1	0
P03F	SPI STEST	SPI PRIOR- ITY	SPI ESPEN	—	—	—	—	—
	RP-0	RP-0	RP-0					

R=Read, W=Write, P=Privileged Write only, -n= Value after reset

- Bits 0–4 - Reserved. Read data is indeterminate.
- Bit 5 - **SPI ESPEN.** Emulator Suspend Enable.  
This bit has no effect except when using the XDS emulator to debug a program; then, this bit determines SPI operation when the program is suspended by an action such as a hardware or software breakpoint.  
  
 0 = When the emulator is suspended, the SPI continues to work until the current transmit/receive sequence is complete.  
 1 = When the emulator is suspended, the the state of the SPI is frozen so that it can be examined at the point that the emulator was suspended.
- Bit 6 - **SPI PRIORITY.** Interrupt Priority Select.  
  
 0 = Interrupts are level 1 (high priority) requests.  
 1 = Interrupts are level 2 (low priority) requests.
- Bit 7 - **SPI STEST**  
This bit must be cleared to ensure proper operation.



Introduction	1
Assembly Language Instruction Set	13
TMS370 Family Devices	2
Design Aids	14
CPU and Memory Organization	3
Development Support	15
System and Digital I/O Configuration	4
Electrical Specifications	16
Interrupts and System Reset	5
Customer Information	17
EEPROM Modules	6
Appendices	A-H
Timer 1 Module	7
Timer 2 Module	8
Serial Communications Interface (SCI) Port	9
Serial Peripheral Interface (SPI) Module	10
Analog-to-Digital Converter Module	11
TMS370 Programmable Acquisition and Control Timer	12



# Analog-to-Digital Converter Module

---

---

This chapter discusses the architecture and programming of the Analog-to-Digital Converter module of the TMS370 family and covers the following topics:

<b>Section</b>	<b>Page</b>
11.1 Analog-to-Digital Converter (A/D) Overview .....	11-2
11.2 A/D Operation .....	11-5
11.3 A/D Example Program .....	11-8
11.4 A/D Control Registers .....	11-10

## 11.1 Analog-to-Digital Converter (A/D) Overview

The Analog-to-Digital Converter module (A/D) is an 8 bit successive approximation converter with internal sample-and-hold circuitry. The module has eight multiplexed analog input channels which allows the processor to convert the voltage levels from up to 8 different sources.

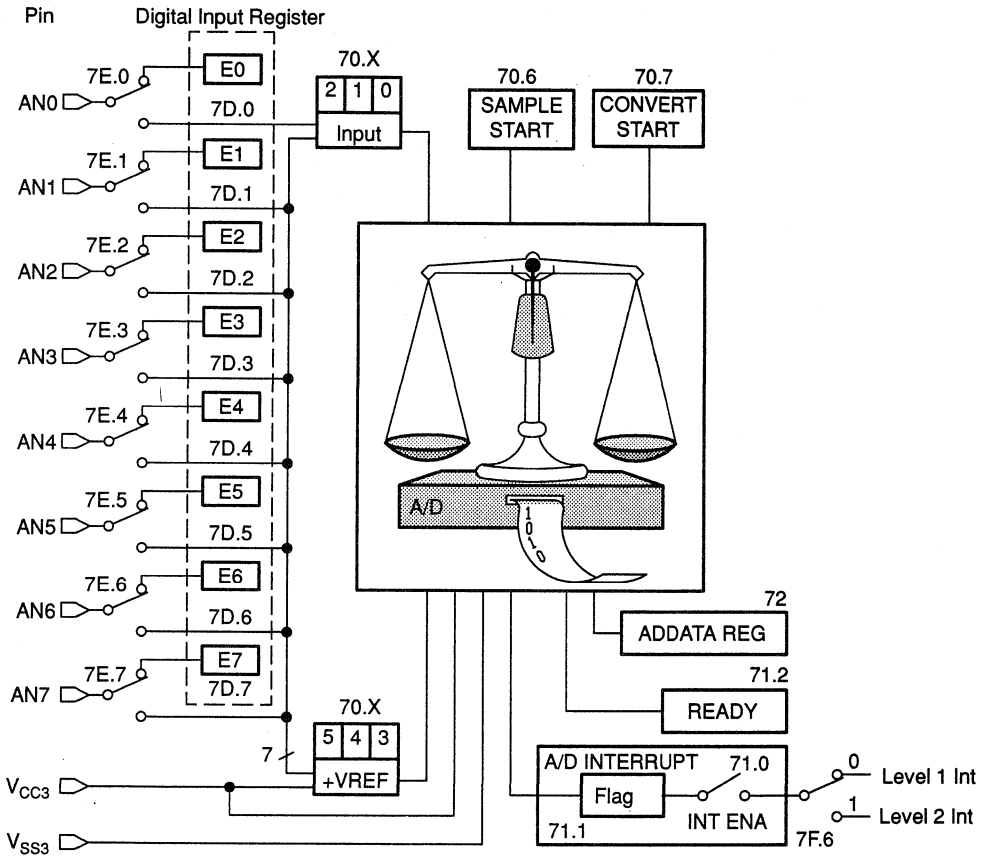
### 11.1.1 A/D Physical Description

The A/D module, shown in Figure 11–1, consists of:

- ❑ Eight analog input channels (AN0—AN7), any of which can be software configured as digital inputs (E0—E7) if not needed as analog channels,
- ❑ An A/D Input Selector (INPUT),
- ❑ A +V<sub>REF</sub> Input Selector (+V<sub>REF</sub>),
- ❑ The Analog-to-Digital Converter (A/D),
- ❑ The ADDATA register which contains the digital value of a completed conversion, and
- ❑ A/D module control registers.

The input channels can be routed through either the channel selector or the positive voltage selector. The A/D converter then processes these signals and puts the result in the ADDATA register. The A/D interrupt circuit informs the rest of the system when a conversion has completed.

Figure 11–1. Analog-to-Digital Converter Block Diagram



### 11.1.2 A/D Control Registers

The A/D Control registers occupy Peripheral File Frame 7 as shown in Table 11–1.

**Table 11–1. A/D Memory Map**

Peripheral File Location	Symbol	Name
P070	ADCTL	Analog Control Register
P071	ADSTAT	Analog Status and Interrupt Register
P072	ADDATA	Analog Conversion Data Register
P073 - P07C		Reserved
P07D	ADIN	Port E Data Input Register
P07E	ADENA	Port E Input Enable Register
P07F	ADPRI	Port E Interrupt Priority Register

## 11.2 A/D Operation

The following sections describe the functions and options of the A/D module.

### 11.2.1 Input/Output Pins

The A/D module uses 10 pins to connect it to the external world. Eight of the 10 pins (AN0—AN7) are individually configured as general purpose input pins when not used as analog inputs.

Seven of the eight analog channels (AN1—AN7) are also available as the positive input voltage reference. This feature allows a weighted measurement or ratio of one channel to another.

The analog voltage supply pins  $V_{CC3}$  and  $V_{SS3}$  isolate the A/D module from digital switching noise which may be present on the other power supply pins. This isolation provides a more accurate conversion. Power to the  $V_{CC3}$  and  $V_{SS3}$  pins should run on separate conductors from the other power lines. Power conductors to the  $V_{CC3}$  and  $V_{SS3}$  should be as short as possible, and the two lines should be properly decoupled. Other standard noise reduction techniques should be applied to help provide a more accurate conversion.

$V_{REF}$  can be chosen to be either  $V_{CC3}$  or one of the analog input channels AN1 to AN7.  $V_{CC3}$  must provide power to the A/D module even if it does not provide the voltage reference. A channel configured as the  $+V_{REF}$  for one conversion can be changed to an analog input channel for the next conversion.

### 11.2.2 A/D Sampling Time

The application program controls the length of the sample time which provides the flexibility to optimize the conversion process for both high and low impedance sources. The program should wait 1  $\mu$ s for each kilohm of source output impedance or a minimum of 1  $\mu$ s for low impedance sources.

### 11.2.3 A/D Conversion

The digital result of the conversion process is given in the following formula.

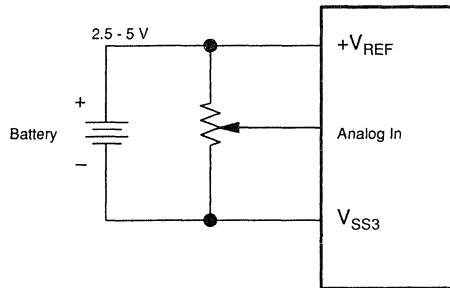
$$\text{Digital result} = 255 \times \text{Voltage of input} / \text{Voltage of reference}$$

The conversion process takes 164 cycles which results in a conversion time of 32.8 microseconds at 20 MHz. A maximum of 27,600 conversions per second are possible at 20 MHz including setting up the conversion, sampling, converting and saving the results.

In Ratiometric conversions, the conversion value is a ratio of the  $V_{REF}$  source to the analog input. As  $V_{REF}$  is increased, the input voltage needed to give a certain conversion value changes; but all conversion values keep the same relationship to  $V_{REF}$ . That is, one half of  $V_{REF}$  always results in the value 080h regardless of the value of  $V_{REF}$  (assuming that  $V_{REF}$  is in the range of 2.5 to 5.5 volts above  $V_{SS3}$ ).

Figure 11–2 shows an example of Ratiometric conversion. In this example, the digital result of the conversion indicates the position of the potentiometer wiper even if the battery loses voltage over time. The A/D conversion always gives the ratio of the resistor values on either side of the wiper even if  $V_{REF}$  drops from 5.0 to 2.5 volts.

**Figure 11–2. Ratiometric Conversion Example**



### 11.2.4 A/D Interrupts

The A/D module sets the AD INT FLAG bit (ADSTAT.1) at the end of the conversion process. If both the AD INT FLAG and the AD INT ENA bit (ADSTAT.0) are set, then the module generates an interrupt request. This interrupt request may be asserted on either the high priority level 1 or the lower priority level 2 depending on the AD PRIORITY bit (ADPRI.6).

The program must clear the AD INT FLAG or else the same interrupt will cause the CPU to enter the interrupt routine again. If the AD INT ENA bit is cleared without clearing the flag, the interrupt is reasserted when the AD INT ENA bit is again set.



### 11.2.5 A/D Programming Considerations

The programmer should follow these steps to obtain data from the A/D converter.

- 1) Write to the ADCTL register to:
  - a) Select the Analog channel (ADCTL.2—0).
  - b) Select the  $V_{REF}$  source (ADCTL.5—3).
  - c) Set the SAMPLE START bit to 1 (ADCTL.6).
- 2) Wait for the sample time to elapse.
- 3) Set the CONVERT START bit (ADCTL.7); leave the SAMPLE START bit (ADCTL.6) set.
- 4) Wait for either the interrupt flag to be set or the A/D interrupt to occur.
- 5) Read the conversion data register (ADDATA).
- 6) Clear the interrupt flag bit (ADSTAT.1).

To begin sampling, set the SAMPLE START bit. The program should wait 1  $\mu$ s for each kilohm of source output impedance or a minimum of 1  $\mu$ s for low impedance sources. When the sample time completes, set both the SAMPLE START and CONVERT START bits.

Eighteen cycles after the program sets the CONVERT START bit, the A/D module clears both the SAMPLE START and CONVERT START bits to signify the end of the internal sampling phase. After these bits are cleared, the program can change the input channel without affecting the conversion process. The voltage reference source  $V_{REF}$  should remain constant throughout the conversion.

To stop a conversion in progress set the SAMPLE START bit to 1 anytime after the A/D clears this bit. The entire conversion process requires 164 system clock cycles after the program sets the CONVERT START bit.

### **11.3 A/D Example Program**

This example program samples and converts data from all 8 channels and stores the digital results into a table beginning at ATABLE. The routine stops interrupting the main program after it finishes all eight channels. If the main program wants more recent data it needs only to execute the code at RESTART and the A/D routine will again sample and convert all eight channels of data. The A/D interrupt enable bit is cleared by the A/D interrupt routine as a signal to the main program that all eight channels have been processed. The address of the label ATOD must be placed into the interrupt vector table located at 7FECh and 7FEDh.

```

ADCTL      .EQU P070          ;A/D control register
ADSTAT     .EQU P071          ;A/D status register
ADDATA     .EQU P072          ;A/D conversion results
ADENA      .EQU P07E          ;A/D input enable
           .REG ADCHANL      ;keeps current channel number
           .REG ATABLE,8     ;8 byte table that stores
                               ; channel data, lsb first

;
INIT       MOV    #0,ADENA    ;all channels to A/D inputs
           CALL   RESTART    ; (reset condition)
           ;start taking data

;
;       MAIN PROGRAM GOES HERE
;
;       .
;
;       CALL   RESTART      ;start taking more data
;       .
;
;       MORE MAIN PROGRAM
;
;
;       SUBROUTINE SECTION
RESTART    CLR    ADCHANL     ;initialize channel
           MOV    #001h,ADSTAT ;enable interrupts, clear
           ; any flag
           MOV    #040h,ADCTL  ;start sampling (approx. 2 μs
           ; delay)
           MOV    #0C0h,ADCTL  ;start converting now; enter
           ; main program
           RTS

;
;       INTERRUPT ROUTINE FOR ANALOG TO DIGITAL CONVERTER
ATOD       PUSH   A           ;save registers
           PUSH   B
           MOV    ADCHANL,B   ;get channel number
           MOV    ADDATA,A    ;get A/D conversion value
           MOV    A,ATABLE(B) ;store in a table according to
           ; channel number
           INC    B           ;point to next channel
           BTJZ   #8,B,GOCNVRT ;stop when all channels sampled
           ; (bit3 =1)
           CLR    ADCHANL     ;reset the A/D channel
           MOV    #0,ADSTAT    ;turn off interrupt and
           ; clear flag
           JMP    EXITA2D     ;all 8 channels taken, enable
           ; set to 0 now

;
;       GOCNVRT
GOCNVRT    MOV    B,ADCHANL   ;store current A/D channel
           MOV    #01h,ADSTAT  ;clear interrupt flag
           OR     #040h,B      ;set up sample bit in value
           MOV    B,ADCTL     ;start sampling channel data
           OR     #080h,ADCTL  ;start converting data

;
;       EXITA2D
EXITA2D    POP    B           ;Restore data
           POP    A
           RTI

```

## 11.4 A/D Control Registers

The A/D module control registers occupy Peripheral File Frame 7, as shown in Table 11–2. The bits shown in shaded boxes in Table 11–2 are Privilege Mode bits, that is, they can only be written to in the Privilege Mode.

Table 11–2. Peripheral File Frame 7: A-to-D Converter Control Registers

		PERIPHERAL FILE FRAME 7: A-TO-D CONVERTER CONTROL REGISTERS								
ADDR	PF	BIT 7	BIT 6	BIT 5	BIT 4	BIT 3	BIT 2	BIT 1	BIT 0	
1070h	P070	CONVERT START	SAMPLE START	REF VOLT SELECT 2	REF VOLT SELECT 1	REF VOLT SELECT 0	AD INPUT SELECT 2	AD INPUT SELECT 1	AD INPUT SELECT 0	ADCTL
1071h	P071	—	—	—	—	—	AD READY	AD INT FLAG	AD INT ENA	ADSTAT
1072h	P072	A-TO-D CONVERSION DATA REGISTER								ADDATA
1073h TO 107Ch	P073 TO P07C	RESERVED								
107Dh	P07D	PORT E DATA INPUT REGISTER								ADIN
107Eh	P07E	PORT E INPUT ENABLE REGISTER								ADENA
107Fh	P07F	AD STEST	AD PRIORITY	AD ESPEN	—	—	—	—	—	ADPRI

### 11.4.1 Analog Control Register (ADCTL)

The ADCTL register controls the input selection, reference voltage selection, sample start and conversion start.

**Analog Control Register, (ADCTL)**  
[Memory Address - 1070h]

BIT#-	7	6	5	4	3	2	1	0
P070	CON- VERT START	SAMPLE START	REF VOLT SELECT2	REF VOLT SELECT1	REF VOLT SELECT0	AD INPUT SELECT2	AD INPUT SELECT1	AD INPUT SELECT0
	RW-0	RW-0	RW-0	RW-0	RW-0	RW-0	RW-0	RW-0

R=Read, W=Write, -n= Value after reset

Bits 0-2 - **AD INPUT SELECT0—2.** Analog Input Channel Select Bits 0—2.  
These bits select the channel used for conversion. Channels should be changed only after the A/D has cleared the SAMPLE START and CONVERT START bits. Changing the channel while either SAMPLE START or CONVERT START is 1 invalidates the conversion in progress.

AD Input Select2	AD Input Select1	AD Input Select0	Channel
0	0	0	AN0
0	0	1	AN1
0	1	0	AN2
0	1	1	AN3
1	0	0	AN4
1	0	1	AN5
1	1	0	AN6
1	1	1	AN7

Bits 3-5 - **REF VOLT SELECT0—2.** Reference Voltage ( $+V_{REF}$ ) Select Bits 0—2.  
These bits select the channel the A/D uses for the positive voltage reference. REF VOLT SELECT bits must not change during the entire conversion.

Ref Volt Select2	Ref Volt Select1	Ref Volt Select0	$+V_{REF}$ Source
0	0	0	$V_{CC3}$ †
0	0	1	AN1
0	1	0	AN2
0	1	1	AN3
1	0	0	AN4
1	0	1	AN5
1	1	0	AN6
1	1	1	AN7

† Pin AN0 can not be selected as positive voltage reference.

- Bit 6 - **SAMPLE START.** Sample Start.  
Setting this bit stops any ongoing conversion and starts sampling the selected input channel to begin a new conversion. This bit is cleared by the A/D module 18 system-clock cycles after the program sets the CONVERT START bit. Entering Halt or Standby mode clears this bit and aborts any sampling in progress.
  
- Bit 7 - **CONVERT START.** Conversion Start.  
Setting this bit starts the conversion. This bit is cleared by the A/D 18 system clock cycles after the program sets the CONVERT START bit. Entering Halt or Standby mode clears this bit and aborts any conversion in progress.

## 11.4.2 Analog Status and Interrupt Register, (ADSTAT)

The ADSTAT register indicates the converter and interrupt status.

**Analog Status and Interrupt Register, (ADSTAT)**  
[Memory Address - 1071h]

BIT#	7	6	5	4	3	2	1	0
P071	—	—	—	—	—	AD READY	AD INT FLAG	AD INT ENA
						R-1	RC-0	RW-0

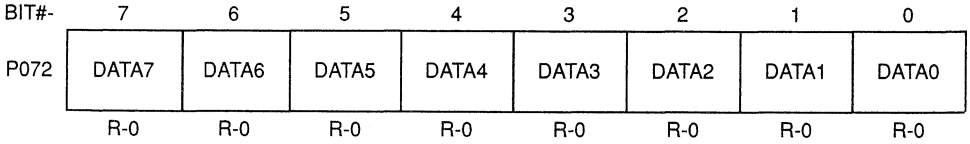
R=Read, W=Write, C=Clear only, -n= Value after reset

- Bit 0 - **AD INT ENA.** A/D Interrupt Enable.  
This bit controls the A/D module's ability to generate an interrupt.  
0 = Disables A/D interrupt.  
1 = Enables A/D interrupt.
- Bit 1 - **AD INT FLAG.** A/D Interrupt Flag.  
The A/D module sets this bit at the end of an A/D conversion. If this bit is set while the AD INT ENA bit is set, an interrupt request is generated. Clearing this flag clears pending A/D interrupt requests. This bit is cleared by the system reset or by entering Halt or Standby mode. Software cannot set this bit.
- Bit 2 - **AD READY.** A/D Converter Ready.  
The A/D module sets this bit whenever a conversion is not in progress and the A/D is ready for a new conversion to start. Writing to this bit has no effect on its state.  
0 = Conversion in process.  
1 = Converter ready.
- Bits 3-7 - Reserved. Read data is indeterminate.

### 11.4.3 Analog Conversion Data Register (ADDATA)

The ADDATA register contains the digital result of the last A/D conversion.

**Analog Conversion Data Register (ADDATA)**  
[Memory Address - 1072h]



R=Read, -n= Value after reset

The analog-to-digital conversion data is loaded into this register at the end of a conversion and remains until replaced by another conversion.



### 11.4.4 Analog Port E Data Input Register (ADIN)

The ADIN register contains digital input data when one or more of the AN0 through AN7 pins are used as digital ports.

**Analog Port E Data Input Register (ADIN)**  
[Memory Address - 107Dh]

BIT#-	7	6	5	4	3	2	1	0
P07D	PORT E DATA AN 7	PORT E DATA AN 6	PORT E DATA AN 5	PORT E DATA AN 4	PORT E DATA AN 3	PORT E DATA AN 2	PORT E DATA AN 1	PORT E DATA AN 0
	R-0	R-0	R-0	R-0	R-0	R-0	R-0	R-0

R=Read, -n= Value after reset

The ADIN register shows the data present at the pins configured for general purpose input instead of A/D channels. A bit is configured as a general purpose input if the corresponding bit of the port enable register is a 1. Pins configured as A/D channels are read as 0s. Writing to this address has no effect.

### 11.4.5 Analog Port E Input Enable Register (ADENA)

The ADENA register controls the function of the AN0 through AN7 pins.

**Analog Port E Input Enable Register (ADENA)**  
 [Memory Address - 107Eh]

BIT#-	7	6	5	4	3	2	1	0
P07E	PORT E INPUT ENA 7	PORT E INPUT ENA 6	PORT E INPUT ENA 5	PORT E INPUT ENA 4	PORT E INPUT ENA 3	PORT E INPUT ENA 2	PORT E INPUT ENA 1	PORT E INPUT ENA 0
	RW-0	RW-0	RW-0	RW-0	RW-0	RW-0	RW-0	RW-0

R=Read, W=Write, -n= Value after reset

The ADENA register individually configures the eight pins AN0-AN7 as either analog input channels or as general purpose input pins.

- 0 = The pin becomes an analog input channel for the A/D converter.  
 When the bit is 0, the corresponding bit in the ADIN register reads as a 0.
- 1 = Enables the pin as a general purpose input pin and its digital value can be read from the corresponding bit in the Port E Data Input Register.

## 11.4.6 Analog Interrupt Priority Register (ADPRI)

The ADPRI register selects the interrupt priority level of the A/D interrupt.

**Analog Interrupt Priority Register (ADPRI)**  
[Memory Address - 107Fh]

BIT#-	7	6	5	4	3	2	1	0
P07F	AD STEST	AD PRIOR- ITY	AD ESPEN	—	—	—	—	—
	RP-0	RP-0	RP-0					

R=Read, P=Privileged Write, -n= Value after reset

Bits 0-4 - Reserved. Read data is indeterminate.

Bit 5 - **AD ESPEN.** Emulator Suspend Enable.  
Normally, this bit has no effect. However, when using the XDS emulator to debug a program, this bit determines what happens to the A/D when the program is suspended by an action such as a hardware or software breakpoint.

0 = When the emulator is suspended, the A/D continues to work until the current conversion is complete.

1 = When the emulator is suspended, the A/D is frozen so that its state can be examined at the point that the emulator was suspended. The conversion data is indeterminate upon restart.

Bit 6 - **AD PRIORITY.** A/D Interrupt Priority Select.  
This bit selects the priority level of the A/D interrupt.

0 = A/D interrupt is a higher priority (level 1) request.

1 = A/D interrupt is a lower priority (level 2) request.

Bit 7 - **AD STEST.** This bit must be cleared (0) to ensure proper operation.



Introduction	1
Assembly Language Instruction Set	13
TMS370 Family Devices	2
Design Aids	14
CPU and Memory Organization	3
Development Support	15
System and Digital I/O Configuration	4
Electrical Specifications	16
Interrupts and System Reset	5
Customer Information	17
EEPROM Modules	6
Appendices	A-H
Timer 1 Module	7
Timer 2 Module	8
Serial Communications Interface (SCI) Port	9
Serial Peripheral Interface (SPI) Module	10
Analog-to-Digital Converter Module	11
TMS370 Programmable Acquisition and Control Timer	12



# TMS370 Programmable Acquisition and Control Timer

---

---

---

This chapter discusses the architecture and programming of the Programmable Acquisition and Control Timer module (PACT). This module acts as a timer co-processor, gathering timing information on input signals and controlling output signals with little or no intervention by the CPU. The co-processor nature of this module allows for levels of flexibility and power not found in traditional microcontroller timers. This chapter covers the following topics:

<b>Section</b>	<b>Page</b>
12.1 Features .....	12-2
12.2 Overview .....	12-3
12.3 Time Base .....	12-4
12.4 Inputs .....	12-5
12.5 Memory Organization .....	12-6
12.6 Control and Outputs .....	12-8
12.7 Architecture .....	12-14
12.8 Input Capture Functions .....	12-19
12.9 Command/Definition Area .....	12-21
12.10 Interrupts .....	12-29
12.11 Watchdog .....	12-32
12.12 SCI .....	12-33
12.13 PWM Example .....	12-34
12.14 PACT Block Diagram .....	12-37
12.15 Peripheral Frame Control Registers .....	12-38

## 12.1 Features

- ❑ Input capture functions on six input pins, including four pins (CP3 to CP6) with a programmable prescaler.
- ❑ Timer-driven outputs on eight pins.
- ❑ Configurable timer overflow rates for different functions.
- ❑ One 8-bit event counter driven by CP6.
- ❑ Up to 20-bit timer capability.
- ❑ Interaction between event counter and timer activity.
- ❑ Register-based organization, allowing single-cycle accesses to parameters.
- ❑ 18 independent interrupt vectors with two priority levels.
- ❑ Integrated, configurable Watchdog with selectable time-out period.
- ❑ Mini Serial Communications Interface with independent setup of Baud rate for receive and transmit lines.



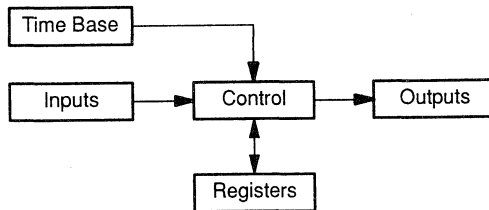
## 12.2 Overview

This chapter is designed as an aid to understanding of the PACT module.

This chapter is written with a bottom's up view of the PACT module. Resist the temptation to skip this chapter because of your previous experience with microcontroller timers. Typically the person who has the most difficulty understanding PACT is the person with the most experience using traditional microcontroller timers because of preconceived ideas.

To make our study of PACT simpler we have broken this module into the sections shown in Figure 12-1 below.

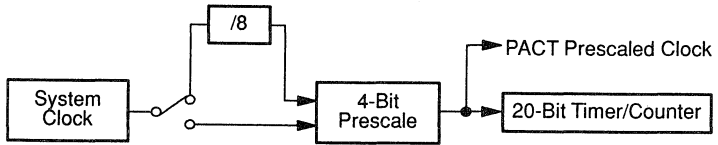
**Figure 12-1. PACT Overview**



## 12.3 Time Base

The time base section of PACT is very similar to that used in traditional timers. The microcontroller system clock is routed to a prescaler that feeds a hardware counter. As seen in Figure 12–2, the prescale section consists of a 4-bit prescaler and an optional divide-by-8 circuit. The hardware counter is 20 bits wide.

**Figure 12–2. Time Base Block Diagram**

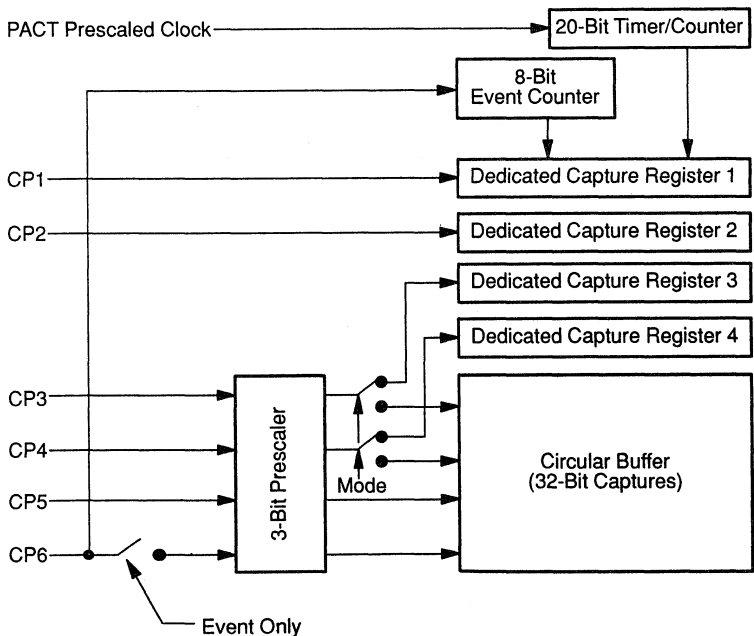


## 12.4 Inputs

Figure 12–3 shows a block diagram of the input capture section of PACT. PACT has six input capture pins. How these pins are used depends on the PACT operating mode. In mode A, two pins cause captures to dedicated capture registers and the other four cause captures to a circular buffer. In mode B, four pins cause captures to dedicated capture registers and the other two cause captures to the circular buffer. All input pin captures are 32 bits long and consist of the 20-bit hardware timer, the 8-bit event counter, and 4 extra bits used to identify the pin that caused the capture in the circular buffer. Captures can be set to occur on the falling, rising, or both edges of the input signal. Input pin CP6 also runs the 8-bit event counter.

Capture pins CP3 through CP6 may be prescaled with a divide value from 1 to 8. Each of these four pins has its own edge counter, but the maximum count value (1–8) before an actual capture occurs must be the same for all four pins.

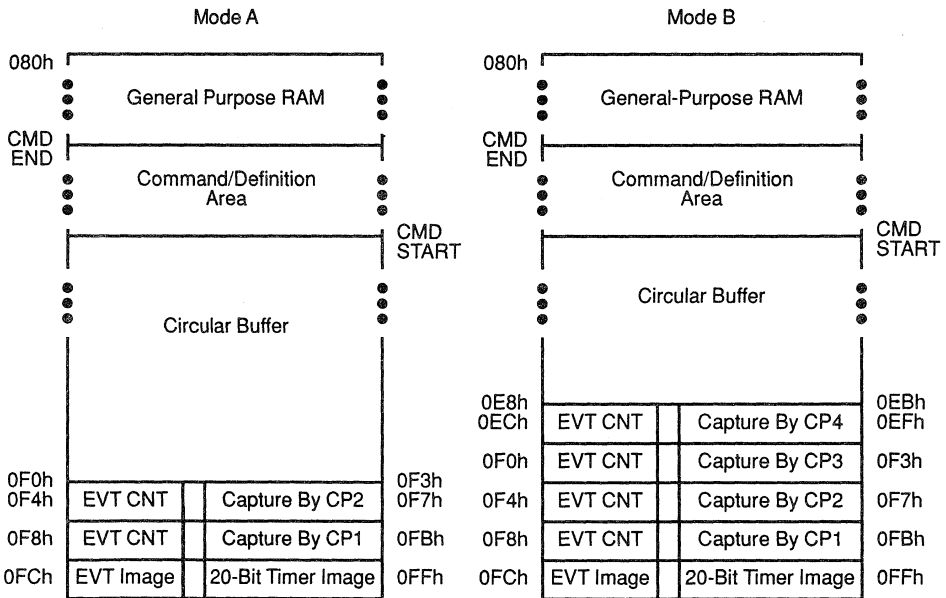
**Figure 12–3. Input Capture Block Diagram**



## 12.5 Memory Organization

One of the major differences between the PACT module and standard timers is the location of the capture registers. The capture registers are actually locations in a dual-port RAM. These locations can be read or written by the CPU. They are automatically written to by PACT when the appropriate feature is enabled. The dual-port RAM is 128 bytes long as shown in Figure 12–4.

**Figure 12–4. Dual-Port RAM Organization**



The architecture of PACT does not care where the dual-port RAM is located in the memory map, but by convention it is located in the register file from 0080h to 00FFh. This allows maximum access speed to these registers by the CPU when using the register address mode. The locations 0FCh – 0FFh of this dual port memory contain an image of the 20-bit default time, and an image of the 8-bit event counter. Since they are images, or more precisely, copies of the actual hardware registers, they can be over written by the application software. However, they will be rewritten every time the PACT module receives another prescaled clock. The 32-bit capture registers are directly before the timer and event counter images. The circular buffer is directly before the capture registers. The length of the circular buffer is de-

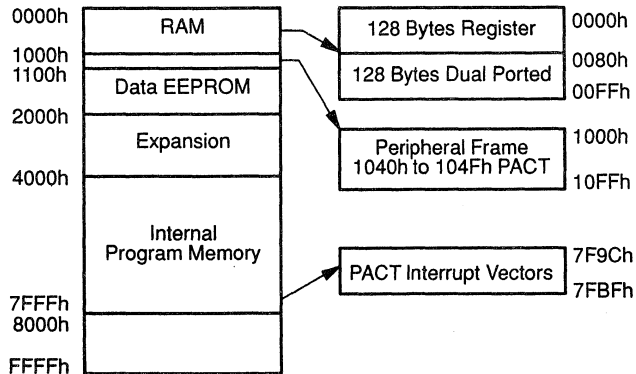
defined by the user. Five bits in the peripheral file define the start of the Command/Definition area which in effect also defines the size of the circular buffer. The purpose of the Command/Definition area will be discussed in Section 12.6.

Since it takes several system clock periods for the CPU to read a 20-bit timer capture value, it is possible for an additional capture to occur while reading the original capture. The user's program can detect this situation by clearing the capture flag in the peripheral file before reading the capture value and then verifying that the flag has not been set again after the read is complete. If the flag was set again, the value read may be invalid and should be reread.

The actual memory address of the PACT dual-port RAM is not determined by the PACT module, but rather by the end device. The memory map in Figure 12-5 is a typical implementation of PACT. Note that there are three areas of memory that are used by the PACT module.

The 128 bytes of dual-port RAM contain the capture registers, the circular buffer and a command/definition area. The peripheral frame contains the hardware registers used for initial setup. It is described in Section 12.15. The interrupt vectors must be setup by the programmer. This area is described in Section 12.10.

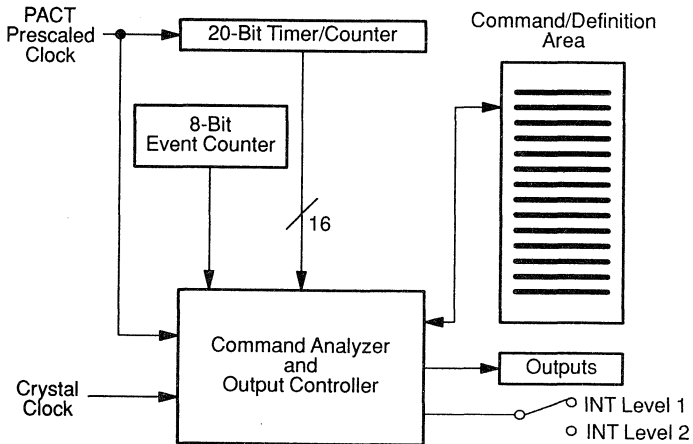
**Figure 12-5. RAM Organization**



## 12.6 Control and Outputs

The control and outputs section of PACT is perhaps the most unique and most powerful part of this timer. The controller acts like a state machine. The controller is started when it receives a rising edge from the PACT prescaled clock. The controller reads its commands (or state microcode) from the command definition part of the dual-port RAM. The 8-bit event counter and the 16 least significant bits of the 20-bit default counter are also input into the controller for use in comparisons. The outputs from the controller are used to set or clear the 8 output pins. The prescaled clock from the PACT time base is only used to start the controller. The controller steps through its commands as fast as it can, using the system clock phases for synchronization. The controller must step through all of the commands in the command/definition area before the next rising edge of the prescaled clock. The next prescaled clock increments the 20-bit default counter and starts the whole process over.

**Figure 12–6. Output Control Section**

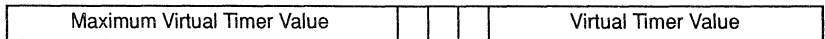




we want a PWM output with an initial duty cycle of 75%. Using one standard compare command, set the timer compare value to 04000h (1/4 the overflow rate), set the actions to cause an output pin to go high when the count is equal to the compare value and then low again when the least significant 16 bits of the counter are zero. The duty cycle can be varied by changing the 16-bit compare value. The signal can be inverted by selecting clear on compare equal, as opposed to set on compare equal. The only thing that is missing is a way to vary the period of the PWM.

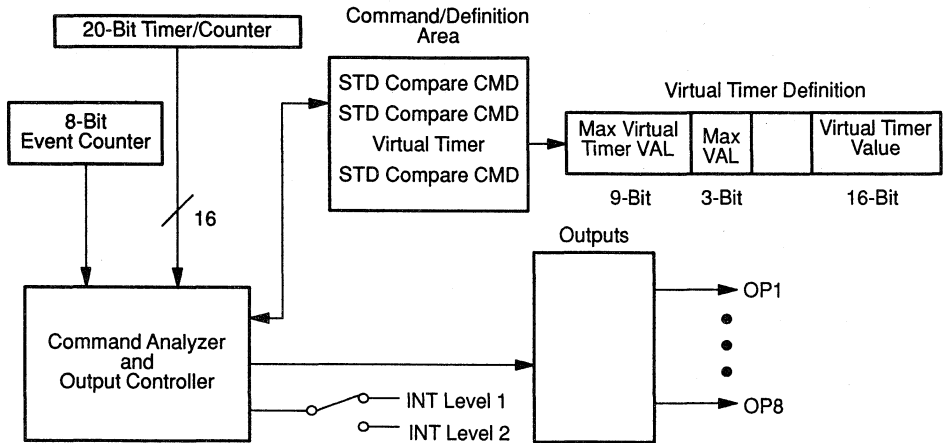
### 12.6.2 Virtual Timers

The way to vary the period of the PWM is with the use of a virtual timer. Keep in mind that the command/definition area is implemented in RAM. Figure 12–8 shows the virtual timer definition and its implementation. The virtual timer definition consists of 16 bits that are read, incremented and rewritten on each tic of the PACT clock. Also within the virtual timer definition are 13 bits that define a maximum value. When the virtual timer reaches this maximum value it is reset to zero. A block diagram of the virtual timer definition is shown below. This diagram shows the information contained in the definition. For more information or actual bit definitions refer to Section 12.9.2.1.



The command/definition area of Figure 12–8 shows two standard compare commands, a virtual timer definition and a third standard compare command. Assume that we are using a microcontroller with a 200-ns (5 MHz) internal system clock and we are prescaling the PACT clock with divide by five so that each PACT clock tic is one microsecond. The first two standard compare commands are used to generate PWM signals of variable duty cycle with a period of 65,536 prescaled clock tics (65.536 ms). If we want the third PWM to have a period of one millisecond, then we set up the virtual timer with a maximum value of one thousand. When the controller sees the timer definition, it will increment the virtual timer and then use the virtual timer value for future comparisons. The third standard compare command will generate a PWM of variable duty cycle with a period of one millisecond.



**Figure 12-8. Virtual Timer Implementation**

Combinations of standard compare commands and virtual timers can be used to create complex repeating waveforms. Multiple standard compare commands can be used on a single output pin to create multiple pulses of different duration.

Virtual timers are also used to provide periodic interrupts to the processor.

### 12.6.3 Double Event Compare Command

Actions can also be taken based on comparisons to the 8-bit event counter. Since all commands are 32 bits wide, the double event compare command actually defines two event compare values and the actions that can be performed, based on each value. The allowed actions based on event compare one matching the event counter are:

- Set or reset the selected output pin (OP1–8)
- Interrupt
- Generate a 32-bit capture into the circular buffer

The allowed actions based on event compare two matching the event counter are:

- Set or reset the selected output pin (OP1–8)
- Interrupt
- Generate a 32-bit capture into the circular buffer
- Reset the 20-bit default timer

Because of synchronization, these actions will occur two or three prescaled clock cycles after the input edge that incremented the event counter. A block diagram of the double event command is shown below. This diagram shows the information contained in the command. For more information or actual bit definitions refer to Section 12.9.2.6.

				Event 1 actions	Event 2 actions	Pin Select	Event 2 Compare Value	Event 1 Compare Value
--	--	--	--	-----------------	-----------------	------------	-----------------------	-----------------------

So far we can manipulate output lines based on time values or based on the number of external events. There is an additional virtual timer definition that allows us to manipulate output lines based on a combination of the event counter and time.

### 12.6.4 Offset Timer Definition-Time From Last Event

The Offset Timer Definition-Time From Last Event creates a 16-bit virtual timer that is cleared on each occurrence of an event on pin CP6. This definition also sets an event counter maximum, so that the event counter is reset after reaching this maximum value. The offset timer definition may generate the following actions:

- Generate an interrupt when the maximum event count is reached,
- Store the 16-bit virtual timer in the circular buffer on each event,
- Store the 20-bit default timer and 8-bit event counter in the circular buffer when the maximum event count is reached,
- Reset the 20-bit hardware default timer when the maximum event count is reached.

A block diagram of the offset timer definition is shown below. This diagram shows the information contained in the command. For more information or actual bit definitions refer to Section 12.9.2.3.

Max Event Value				Actions	Virtual Timer Value
-----------------	--	--	--	---------	---------------------

## 12.6.5 Conditional Compare Command

There is also a special compare command that has a timer compare value and an event compare value. Both of these values must match for the defined action to take place. Usually, a series of these commands follows an offset timer definition-time from last event and provides output pulses on different pins, based on the event count and an elapsed time from the event. The actions that may be generated by the conditional compare command are:

- ❑ Generate an interrupt when both conditions are met:
  - 1) The event compare value equals the event counter
  - 2) The timer compare value equals the last defined timer.
- ❑ Set or clear one of seven output pins (OP1– OP7) when the following two conditions are met:
  - 1) The event compare value equals the event counter
  - 2) The timer compare value equals the last defined timer.

The same actions described above may be enabled on the event counter reaching the event compare value plus one without regard to the timer compare value. This allows for the case where the next event occurs before the delay period specified by the timer compare value was reached. A block diagram of the conditional compare command is shown below. This diagram shows the information contained in the command. For more information or actual bit definitions refer to Section 12.9.2.5.

Event Compare Value		Actions	Pin Select	Timer Compare Value
---------------------	--	---------	------------	---------------------

## 12.6.6 Baud Rate Timer Definition

The last item that can be put into the command/definition area of the PACT module is a baud rate virtual timer. This virtual timer runs the serial communications port built into the PACT module. Set up the maximum timer value for one-quarter bit period of the desired baud rate. Separate timers can be defined for transmit and receive. For more information on the baud rate timer definition see Section 12.9.2.2. For more information on the SCI see Section 12.12.

			One Quarter Bit Rate Value	Virtual Timer Value
--	--	--	----------------------------	---------------------

## 12.7 Architecture

The user of the PACT module needs to set up three distinct areas of memory. The first area is the dual-port RAM which contains the capture area and the commands and definitions. The second is a peripheral frame (Frame 4, 104xh). The third is an area near the end of the internal program memory which holds the interrupt vectors for this module.

### 12.7.1 Hardware Pin Allocation

The PACT module has 16 external hardware pins allocated to its functions. Pins are allocated in one of three groups:

- ❑ Inputs (Capture functions) CP1 to CP6 inclusive (six pins). The function of these pins depends on the mode selected;

<u>Mode A</u>	<u>Mode B</u>	
CP1–2	Dedicated capture.	CP1–4
CP3–6	Circular buffer capture.	CP5–6
CP6	Event pin.	CP6

- ❑ 8 Output pins OP1 to OP8 inclusive.
- ❑ SCI (Receive and Transmit Data) RX and TX (two pins).

In the TMS370Cx3x parts, the input pins CP3, CP4, and CP5 are internally bonded with I/O pins D4, D6, and D7 giving the user a software governed choice of function. Output pins (OP1–8) are initialized to a logic low on reset.

### 12.7.2 RAM Organization

PACT is a RAM based module and as such occupies an area of the internal RAM, the size of which is determined by the functions selected by the user.

The PACT module uses memory starting from the highest address going to lower addresses. For the TMS370Cx3x family the highest address of the PACT module's dual-port RAM is 00FFh. An image of the 20-bit default timer, a copy of the flag bits for capture pins 3 to 6, and an image of the 8-bit event counter are always held in the first 32-bit block. Thereafter allocation depends on the mode selected.

Mode A provides two, and Mode B provides four dedicated 32-bit storage locations, which are followed by a circular storage buffer.

Next to the circular buffer is the area used to store commands and definitions (again in 32-bit blocks).

Both the circular buffer and the command file length are software defined by the programmer. Four bits are used to define the start and five bits define

the end of the command area (the two least significant bits, LSbs, are not defined since this area must start and finish on a 32-bit boundary). The start address of the command area also serves to define the length of the circular buffer as it resides between the last dedicated storage location and the start of the command area.

All RAM at lower addresses than the end of the command area may be used for general purposes – registers, stack, etc. However, note that since all the RAM locations above are also within the processor register space, the data in these locations may be directly manipulated with normal register-based instructions.

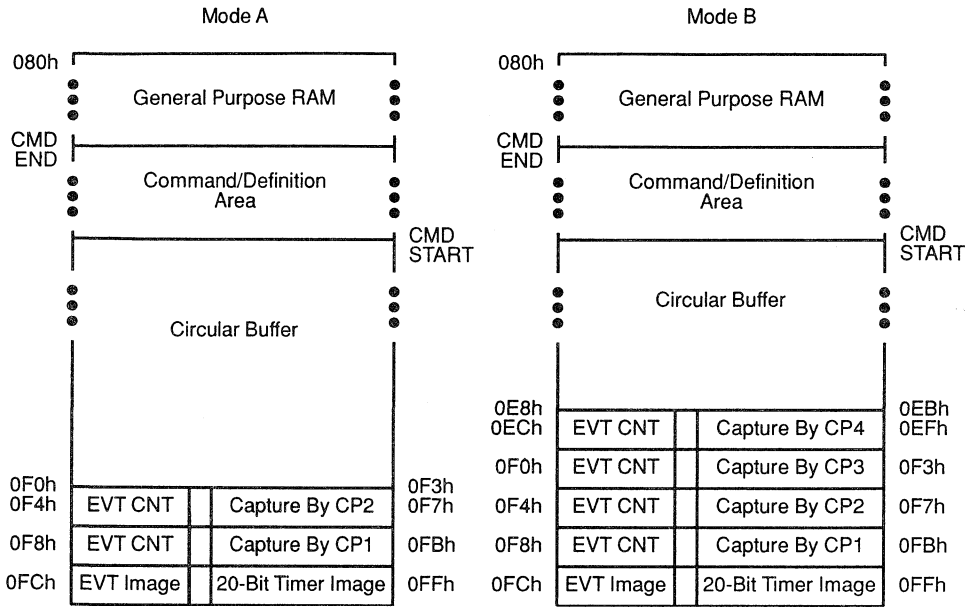
### **12.7.2.1 Mode A**

This mode provides two dedicated capture locations (associated with pins CP1 and CP2) plus four other pins (CP3–6) with a programmable prescaler to store 32-bit data in the circular buffer. The prescaler rate is the same for all of the four pins (CP3–6). Pin CP6 also clocks the 8-bit event counter.

### **12.7.2.2 Mode B**

Mode B provides four dedicated capture locations (associated with pins CP1–4). Pins CP3–6 have a programmable prescaler. Pin CP5 may capture 32-bit data in the circular buffer when the software defined edge occurs. The remaining capture pin, CP6, clocks the 8-bit event counter and may capture 32-bit data in the circular buffer.

**Figure 12–9. Mode A and B RAM Organization**



### 12.7.3 Command/Definition File Format

Entries in the command/definition area are all 32 bits in length. Normally commands are executed sequentially starting with entry 0, the entry next to the circular buffer. Each entry requires a specified number of time slots (see the command/definition descriptions for the number of time slots required for each command).

### 12.7.4 Time Slot Availability

The number of time slots available to the programmer, and hence the number of definitions/commands allowed, is governed by the crystal frequency and the resolution required by PACT functions. It is therefore up to the programmer to balance these factors to suit his application.

It is the PACT prescaler value that effectively determines the number of slots available – the prescaler giving the ratioed crystal frequency against resolution achievable by the PACT. Table 12–1 defines the maximum number of time slots available for all prescaler options.

Should an application require a prescaler value that does not provide sufficient time slots, the step command may be utilized. This effectively halves

the resolution of all commands later in the command/definition area. If 10 entries exist in the command file and entry 2 selects the step mode, then commands 0 – 3 run at full resolution but 4 – 9 run at half resolution.

It must be noted that this affects all operations including the clocking of virtual and offset timers. Repeated use of the step instruction within a command file is meaningless – the commands are either run at full or half speed (no slower).

**Note:**

The Step command affects the second entry after the one containing the command). When step mode is used, the end address of the command/definition area must be programmed as the next to the last address which will be executed.

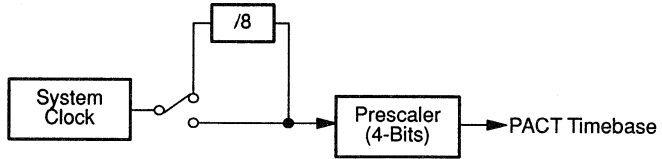
**Table 12–1. Number of Time Slots Available for Each Prescale Setting**

Divide Rate	Time Slots	Divide Rate	Time Slots	Divide Rate	Time Slots
—	—	11	31	56	179
2	2	12	35	64	205
3	5	13	38	72	231
4	9	14	41	80	257
5	12	15	45	88	283
6	15	16	48	96	309
7	19	24	74	104	336
8	21	32	101	112	362
9	25	40	127	120	389
10	29	48	153	128	415

### 12.7.5 Timer Prescaler

All the timers within the PACT module (Default, Virtual Offset) are clocked by the output of the prescaler. This clock rate is set in two parts, a coarse step of divide by 1 or 8 (on system clock) followed by a 4-bit (divide by 1 to 16) block.

**Figure 12–10. Prescaler Circuit**



The divide rate is the binary value of the 4-bit prescaler plus one except for the value zero which, by hardware, provides a divide rate of two. The five bits that control the prescaler are located in the peripheral file at address 1040h. Refer to Section 12.15.1 for more information.

Divide Rate		
Prescaler	Fast Mode Select	
	1	0
0 0 0 0	2	16
0 0 0 1	2	16
0 0 1 0	3	24
0 0 1 1	4	32
0 1 0 0	5	40
0 1 0 1	6	48
0 1 1 0	7	56
0 1 1 1	8	64
1 0 0 0	9	72
1 0 0 1	10	80
1 0 1 0	11	88
1 0 1 1	12	96
1 1 0 0	13	104
1 1 0 1	14	112
1 1 1 0	15	120
1 1 1 1	16	128



## 12.8 Input Capture Functions

This section covers those functions relating to input signals from the six pins available for data capture, (CP1–CP6). For each of the six pins, three bits within peripheral frame 4 select rising edge, falling edge and interrupt enable with a fourth bit acting as the flag that causes an interrupt. By selecting one (or both) of the edges, the capture function for that pin is enabled and the timer value captured will be stored in the location determined by the mode (A or B) in which PACT is operating.

Two distinct modes of operation are available for the PACT module. The choice of mode will normally be decided by the capture functions required. Selection of mode A or B is achieved by clearing or setting the PACT Mode Select bit.

Mode A gives two dedicated pins (CP1–2) with two associated capture registers plus three pins (CP3–5) that capture timer data into the circular buffer. The final pin (CP6) has a software selectable choice to work as event counter pin only or event pin and timer capture pin (into the circular buffer) as CP3–5.

Mode B provides four dedicated pins (CP1–4) and four associated capture registers, one pin (CP5) which captures timer information and stores it in the circular buffer and the final pin (CP6) which has a software selectable choice to work as the event counter pin only or as the event pin and timer capture pin (into the circular buffer) the same as CP5.

Dedicated capture pins always store data into fixed storage locations. The location is defined by the pin triggering the capture. When triggered directly from the pin, capture values are 32 bits long (20-bit default timer, 4-bit ID pin, 8-bit event counter).

A pin ID bit will be set depending on which input caused the capture. Only one of these bits will be set.

Storage of Event Counter	Pin ID	Storage of 20 Bit Default Timer Triggered by Input Pin CPx
--------------------------	--------	--

D31

D23

D20

D0

Bit	Transition on Pin	Result
D20 = 1	CP3	Has caused the Capture
D21 = 1	CP4	Has caused the Capture
D22 = 1	CP5	Has caused the Capture
D23 = 1	CP6	Has caused the Capture

The buffer pointer is available in the peripheral control file to allow the program to know where the last capture value was stored. It is also possible to modify the buffer pointer under processor control.

**Note:**

16-bit captures in the circular buffer are available when triggered by commands in the COMMAND/DEFINITION area. A 32-bit capture can overwrite the last 16-bit capture if it is located at the two higher addresses (address bit0=1 and address bit1=1) of a 32-bit block.

## 12.9 Command/Definition Area

### 12.9.1 Format

All commands/definitions are 32 bits long. They are stored in memory most significant byte first. If byte 3 is stored at location N, then byte 0 would be at location N+3. The bits are referenced as D0–D31.

### 12.9.2 Command/Definition Summary

This section summarizes the available commands and the number of time slots required for each command.

<u>Definitions</u>	<u>Time Slots</u>
Virtual timer definition	2
Baud rate timer definition	2
Offset timer definition	2/3
<u>Commands</u>	<u>Time Slots</u>
Standard compare command	1
Conditional compare command	1
Double event compare command	1

### 12.9.2.1 Virtual Timer Definition

Max Virtual Timer Value					0	Virtual Timer Value	0
-------------------------	--	--	--	--	---	---------------------	---

D31

D0

Requires two time slots

- D0 This bit must be written as a 0 for this command to be valid.
- D1–D15 Virtual Timer Value  
Provides the most significant 15 bits of a 16-bit virtual timer. This timer is resident at this location so any write to this address by the CPU modifies the timer value. Because of hardware limitations the least significant bit of the virtual timer can not be read or written by the CPU, but it is used by the PACT commands such as the standard compare command.
- D16 This bit must be written as a 0 for this command to be valid.
- D17 Interrupt on 0 – Active = 1  
Set interrupt flag when the virtual timer (D1–15) is reset or overflows to zero.
- D18 Enable – Active = 1  
Enables the timer update. Used to stop or start the timer.
- D19 Range Bit  
Used in conjunction with D20–22 to define the maximum value.
- D20–22 Define a further three bits of the maximum value of the virtual timer.  
Either the most significant bits (bits 13-15) of the maximum value if Range bit=1, or the least significant (bits 1-3) if Range bit=0. The undefined bits of the maximum value for the virtual timer are set to 0.
- D23–31 Sets the radical of the maximum value of the virtual timer. Used with D20–22 to specify the maximum value of the virtual timer. The maximum virtual timer value is equal to the desired period minus 2. For example, if a timer with a period of 100 PACT prescaled clocks is desired, the maximum virtual timer value is set to 98. The virtual timer increments from 0 to 99 and is then reset to 0.

Maximum Value Format (D19=0)

0	0	0	D31–D23 = 9 Bit Radical	D22	D21	D20	0
---	---	---	-------------------------	-----	-----	-----	---

Maximum Value Format (D19=1)

D22	D21	D20	D31–D23 = 9 Bit Radical	0	0	0	0
-----	-----	-----	-------------------------	---	---	---	---

### 12.9.2.2 Baud Rate Timer Definition

Max Virtual Timer Value				1	Virtual Timer Value	0
-------------------------	--	--	--	---	---------------------	---

D31

D0

Requires two time slots

- D0            This bit must be written as a 0 for this command to be valid.
- D1–D15      Baud Rate Timer  
Provides the most significant 15 bits of a 16-bit virtual timer used as the baud-rate generator. The timer is resident at this location so any write to this address modifies its value.
- D16           This bit must be written as a 1 for this command to be valid.
- D17           TXselect – Active = 1  
Selects this timer definition as that to be used for the Transmit baud-rate generator.
- D18           RXselect – Active = 1  
Selects this timer definition as that to be used for the Receive baud-rate generator.
- D19           Range bit  
Used in conjunction with D20–22.
- D20–22       Define a further three bits of the maximum value of the virtual timer.  
Either the most significant bits (bits 13-15) of the maximum value if Range bit=1, or the least significant (bits 1-3) if Range bit=0. The undefined bits of the maximum value for the virtual timer are set to 0.
- D23–31       Sets the radical of the maximum value of the virtual timer.  
Used with D20–22 to specify the maximum value of the virtual timer. When the virtual timer reaches the defined value, the next prescaler clock cycle will cause the timer to be cleared.

The maximum virtual timer value should be set to one quarter of the desired bit time minus 2. For more details see Section 12.12.

Maximum Value Format (D19=0)

0	0	0	D31–D23 = 9 Bit Radical	D22	D21	D20	0
---	---	---	-------------------------	-----	-----	-----	---

Maximum Value Format (D19=1)

D22	D21	D20	D31–D23 = 9 Bit Radical	0	0	0	0
-----	-----	-----	-------------------------	---	---	---	---



### 12.9.2.4 Standard Compare Command

Re-served			0	0			Pin Select				Timer Compare Value
-----------	--	--	---	---	--	--	------------	--	--	--	---------------------

D31

D0

Requires one time slot

- D0–15      **Timer Compare Value**  
Provides a 16-bit timer-compare value. The timer with which this value is compared to is either the last virtual timer defined above this command or, if no virtual timer has been defined, the default timer.
- D16        **Next command is a definition – Active = 1**  
Indicates that the following entry in the command/definition area will be a definition.
- D17        **Interrupt on Compare – Active = 1**  
Set interrupt flag when the compare value is matched by the referred timer.
- D18–20    **Pin Selection**  
Select an output pin whose state will be modified when the compare value is matched. The pin number is the binary value of D20–18 (20=msb,18=lsb) plus one.
- D21        **Compare Action – Set = 1, Clear = 0**  
Sets or resets the pin defined by D18–20 when the compare value is matched by the referred timer.
- D22        **Step – Active = 1**  
Allows lower resolution on following commands (see Section 12.7.4 for details on use of this function).
- D23–24    These bits must be written as a 0 for this command to be valid.
- D25        **Reset Action**  
Sets or resets the pin defined by D18–20 when the referred timer is reset to zero. If D25 = 1, the action will be the opposite as defined by D21. If D25 = 0, there will be no action.  
  
0 = no action when the referred timer is zero  
1 = when the referred timer is zero do the opposite action
- D26        **Interrupt on Reset – Active = 1**  
Sets the interrupt flag when the referred timer is reset to zero.
- D27        **Enable Pin – Active = 1**  
Enables output pin actions on this command.
- D28–31    **Reserved**

### 12.9.2.5 Conditional Compare Command

Event Counter Compare Value	1			Pin Select					Timer Compare Value
-----------------------------	---	--	--	------------	--	--	--	--	---------------------

D31

D0

Requires one time slot.

- D0–15      **Timer Compare Value**  
Provides a 16-bit timer compare value. The timer to which this value is compared is either the last virtual timer defined above this command or, if no virtual timer has been defined, the default timer. This is called the referred timer. The value written by the user **MUST** be greater than one.
  
- D16        **Next Command is a Definition Active = 1**  
Indicates that the following entry in the command/definition area will be a definition.
  
- D17        **Interrupt on Compare – Active = 1**  
Set interrupt flag when the timer compare value (D0–15) is matched by the referred timer **and** the event compare value (D24–31) is matched by the event counter.
  
- D18–20    **Pin Selection**  
Select an output pin whose state will be modified when the compare value is matched. The pin number is the binary value of D20–18 (20=msb,18=lsb) plus one except the binary value 111 which disables any pin action. Therefore OP8 is not available for this command.
  
- D21        **Compare Action – Set = 1, Clear = 0**  
Sets or resets the pin defined by Pin Selection when both compare values are matched by the referred timer and the event counter.
  
- D22        **Same Action Active = 1**  
Same action as Compare Action when the event counter reaches the event compare value plus one. This allows an action on the next event if the next event occurs before the time value is reached. If Same Action =0 there will be no action on event compare plus one.
  
- D23        This bit must be written as a 1 for this command to be valid.
  
- D24–31    **Event Compare Value**  
Sets an 8-bit value which is compared with the 8-bit event counter. The actions selected by this command will occur under either of the following conditions:
  - a) The Event Compare Value matches the value of the event counter AND the Timer Compare Value matches the referred timer value, or
  - b) The Same Action Active bit is set AND the event counter matches the Event Compare Value + 1.



### 12.9.2.6 Double Event Compare Command

							1	0			Pin Select			Event 2 Compare Value	Event 1 Compare Value
--	--	--	--	--	--	--	---	---	--	--	------------	--	--	-----------------------	-----------------------

D31

D0

Requires one time slot.

- D0–7            Event 1  
Sets an 8-bit value which, when matched by the 8-bit event counter, causes the action defined by D17, D21 and D29.
- D8–15        Event 2  
Sets an 8-bit value which, when matched by the 8-bit event counter, causes the action defined by D25, 26, 28 and 30.
- D16           Next Command is a Definition – Active = 1  
Indicates that the following entry in the command/definition area will be a definition.
- D17           Interrupt on compare1 – Active = 1  
Set interrupt flag when the event 1 compare value is matched by the event counter.
- D18–20       Pin Selection  
Selects an output pin whose state will be modified when the compare value is matched. The pin number is the binary value of D20–18 (20=msb, 18=lsb) plus one (OP1–8).
- D21           Compare Action1 – Set = 1, Clear = 0  
Sets or resets the pin defined by Pin Selection and Pin Offset when the event 1 compare value (D8–15) is matched by the event counter.
- D22           Step – Active = 1  
Allows lower resolution on the following commands (see Section 12.7.4 for details on use of this function).
- D23           This bit must be written as a 0 for this command to be valid.
- D24           This bit must be written as a 1 for this command to be valid.
- D25           Compare Action2 – No Action = 0    Inverted Action = 1  
Sets or resets the pin defined by Pin Selection when the event2 compare value(D0–D7) is matched by the event counter.  
  
0 = no action  
1 = do the opposite action of Compare Action1
- D26           Interrupt on compare 2 – Active = 1  
Set interrupt flag when event 2 occurs.
- D27           Enable pin – Active = 1  
Enables output pin actions for this command.

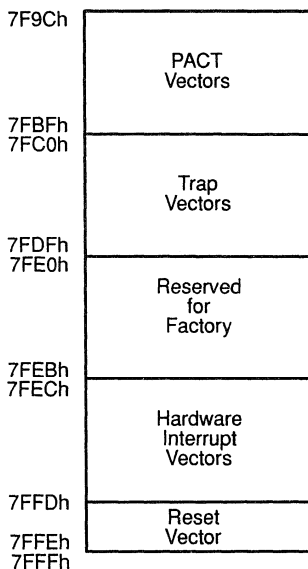
## Command/Definition Area

---

- D28      Event2 default timer Reset – Active = 1  
Reset the default timer when event 2 occurs.
- D29      Event1 default timer Capture – Active = 1  
Store a 32-bit data capture in the circular buffer when event 1 occurs.
- D30      Event2 default timer Capture – Active = 1  
Store a 32-bit data capture in the circular buffer when event 2 occurs.
- D31      Reserved

## 12.10 Interrupts

This section refers to interrupts specific to the PACT module. There are three groups of interrupt vectors. The first is associated with the capture functions, the second with the SCI, and the third with the command/definition area. A total of 18 vectors are available for PACT functions and they are located immediately after the trap vectors in the TMS370 address space. See the memory map below.



As is standard in the TMS370, two levels of priority exist for the interrupts (1 and 2). Each of the three groups of interrupts described above may be allocated to a level. Within each group there is a priority order which determines what order multiple interrupts within a level are serviced (see Table 12-2). There is also an order for servicing groups on the same level (see Table 5-1).

An interrupt vector is either associated with a specific event such as the Receive buffer full for the SCI; a capture on pin X; or in the case of a command or definition, the absolute position of the command or definition within the RAM area.

Interrupts are enabled either in peripheral frame 4 or within the command/definition line. The service routine will normally have to clear the flag associated with the interrupt to prevent multiple servicing of the same interrupt.

**Table 12–2. Interrupt Vector Sources**

Module	Vector Address	Interrupt Source	Interrupt Flag	System Interrupt	Priority in Group†
PACT (Group 2)	7F9Ch, 7F9Dh	PACT SCI TXINT	PACT TXRDY	PTXINT	2
	7F9Eh, 7F9Fh	PACT SCI RXINT	PACT RXRDY	PRXINT	1
PACT (Group 3)	7FA0h, 7FA1h	PACT Cmd/Def Entry 0	CMD/DEF INT 0 FLAG	CDINT0	1
	7FA2h, 7FA3h	PACT Cmd/Def Entry 1	CMD/DEF INT 1 FLAG	CDINT1	2
	7FA4h, 7FA5h	PACT Cmd/Def Entry 2	CMD/DEF INT 2 FLAG	CDINT2	3
	7FA6h, 7FA7h	PACT Cmd/Def Entry 3	CMD/DEF INT 3 FLAG	CDINT3	4
	7FA8h, 7FA9h	PACT Cmd/Def Entry 4	CMD/DEF INT 4 FLAG	CDINT4	5
	7FAAh, 7FABh	PACT Cmd/Def Entry 5	CMD/DEF INT 5 FLAG	CDINT5	6
	7FACh, 7FADh	PACT Cmd/Def Entry 6	CMD/DEF INT 6 FLAG	CDINT6	7
	7FAEh, 7FAFh	PACT Cmd/Def Entry 7	CMD/DEF INT 7 FLAG	CDINT7	8
PACT (Group 1)	7FB0h, 7FB1h	PACT Circular Buffer (Half/Full)	BUFFER HALF/FULL INT FLAG	BUFINT	1
	7FB2h, 7FB3h	PACT CP6 Edge	CP6 INT FLAG	CP6INT	2
	7FB4h, 7FB5h	PACT CP5 Edge	CP5 INT FLAG	CP5INT	3
	7FB6h, 7FB7h	PACT CP4 Edge	CP4 INT FLAG	CP4INT	4
	7FB8h, 7FB9h	PACT CP3 Edge	CP3 INT FLAG	CP3INT	5
	7FBAh, 7FBBh	PACT CP2 Edge	CP2 INT FLAG	CP2INT	6
	7FBCh, 7FBDh	PACT CP1 Edge	CP1 INT FLAG	CP1INT	7
	7FBEh, 7FBFh	PACT Default Timer Overflow	DEFTIM OVRFL INT FLAG	POVRFL INT	8

† 1 is the highest priority.

**Note:**

- 1) CP1–6 interrupts are caused by the software edge(s) selected for that particular pin in peripheral frame 4. The associated interrupt enable bit in frame 4 must also be set for that particular pin. Interrupts set in a command/definition line relate to their position in that area.
- 2) The entry address is derived from bits 2, 3 and 4 of the address. If the command or definition is at address 006Ch, 006Dh, 006Eh and 006Fh (32 bits) then 0110 11xx is the binary value of the address. The entry address comes from bits 4–3–2 = 011 = Entry 3. Thus, the vector associated with entry address 3 will be used when this command or definition causes an interrupt.

It should be noted that for command/definition areas that contain more than eight entries the entry vectors become overlaid and the program must determine the correct source. Entry 0 has the same vector as entry 8. So the command/definition at address 04Ch, 04Dh, 04Eh, 04Fh has the same interrupt vector as the command/definition located at address 06Ch, 06Dh, 06Eh, 06Fh. Both are entry 3.

## 12.11 Watchdog

At power-up the Watchdog is always enabled with the lower time-out period (bit 9 of default timer).

A Watchdog originated reset is normally generated when a software-selected bit of the default timer toggles. There are three options that determine the Watchdog time-out period plus a disable watchdog code:

WD2	WD1	Options
0	0	Reset when Bit 9 of default timer toggles
0	1	Reset when Bit 15 of default timer toggles
1	0	Reset when Bit 19 of default timer toggles
1	1	Disable Watchdog

These bits are resident in peripheral frame 4 at address 104Fh (see Section 12.15.14 for details). They are available to the programmer only in privileged mode immediately after powerup.

Once a period has been selected by the above means, the alternate key bytes, 55h and AAh (55h first) must be written to location 104Eh (peripheral frame 4) to avoid a Watchdog-originated reset being issued. The only exception to this occurs when the default counter is being cleared by the PACT module. In this case a Watchdog-originated reset will occur whenever the default timer is cleared, unless the correct keyword (55h/AAh) has been written since the previous clear.

The Watchdog is stopped in standby mode and halt mode.

## 12.12 Serial Communication Interface (SCI)

The SCI works as a simplified full duplex UART, transmitting 8-bit words with a fixed format of one start and one stop bit. If parity transmission is required, the parity bit must be calculated by the CPU and placed in the transmit buffer as part of the 8-bit word. Parity reception is facilitated by the parity result bit. This bit allows the processor to check for parity errors by comparing the bit (SCICTLP.5) against 0 or 1 for even or odd parity. Hence, there is no parity error bit to be checked by the processor.

There is no overrun detection. The PACT SCI has a shift register and a buffer register. This gives the program a full data byte reception time to read the previous byte before it is overwritten.

During reception the start bit is detected on the falling edge and then sampled again in the center of the bit to avoid false detection. All other bits are sampled once at their centers. If at least one stop bit is not detected when it is expected, the framing error flag (P045.3) is set. This bit will remain set until cleared by reset, SCI software reset, or by writing a zero to it.

The baud rate is determined by setting the maximum virtual timer value to one quarter of the desired bit time minus 2. For example, if the system clock period is 200 ns and the prescale value is 5, then the PACT resolution is 1  $\mu$ s. If a baud rate of 9600 is desired, the maximum virtual timer value should be:

$$\begin{aligned} \text{Max Virtual Timer Value} &= \frac{1}{(\text{Baud Rate})(4)(\text{PACT Resolution})} - 2 \\ &= \frac{1}{(9600)(4)(10^{-6})} - 2 = 24 \end{aligned}$$

The software selectable baud rates (RX and TX may be different) are set up as shown in Section 12.9.2.2. Receive and transmit operations may be stopped or started by using the control bits within the Baud rate definition command).

The data being received and transmitted is accessed in the same peripheral frame (4) as are the control bits. Received data is held at 1046h; transmitted data, at 1047h.

## 12.13 PWM Example

The following routine is an example of how to do a pulse width modulated signal using the PACT module. This routine is composed of three main parts. The first part defines the bytes that will make up the command/definition area. The second part copies the command/definition area bytes from ROM to the dual-port RAM. The third part sets up the PACT peripheral file.

### 12.13.1 Defining the Command/Definition Area

To simplify the task of setting up the Command/Definition area a macro file has been used. The macro file PACT.H is included as Appendix G of this manual. Since this file is subject to change as improvements are found, we recommend that you download the latest version of this file from the microcontroller bulletin board.

To do the PWM signal a virtual timer definition is needed to establish the timer period and a standard compare command follows to determine the period and the polarity of the signal. Since the PACT command/definition area can not start with a definition, an additional standard compare command is inserted at the beginning with only the Next Command is a Definition bit set.

Line 8 of the routine causes the bytes that will become the commands and definitions to be located in a separate section. In this example we have this section starting at location 7800h. Line 10 is the dummy standard compare command. Line 11 is the virtual timer definition. The period is set to 1000 usec and the virtual timer is enabled. Note that the macro takes care of subtracting two from the maximum count value as it creates the proper byte sequence. Line 12 is the standard compare command that sets the period to 800  $\mu$ sec or 80% and selects output pin 1. The default value is to set the pin high on compare equal and opp\_act is selected to cause the pin to go low when the timer is reset. Notice how multiple actions are concatenated with the | operator in this command.

### 12.13.2 Copying the Command/Definition Area to Dual-Port RAM

Since the dual-port RAM must be initialized after power-up, the initial values for the Command/Definition area were defined in non-volatile memory. This part of the routine copies the initial values from the non-volatile memory to the dual-port RAM. Since the PACT module works its way through memory from high addresses to lower addresses but the assembler works through memory from low addresses to higher addresses, this routine flips the table end for end as it is copied into the dual-port RAM. This makes the table much easier to read.

Two variables must be defined before this routine is used. The first, cmd\_st, is the start of the Command/Definition area (the largest address in that



area). Its value is dependant on the mode used and the size of the desired circular buffer. It is defined in line 16 of this routine. The second variable, len, is defined in line 13 as the number of bytes in the Command/ Definition area.

### 12.13.3 Initializing the PACT Peripheral Frame

The last part of the PWM routine sets up the PACT peripheral frame. First the mode is chosen in line 27. Then the Command/Definition start is chosen in line 28 and the end is chosen in line 29. Finally, the timer resolution is set to 1 microsecond and the Command/Definition area is enabled in line 31. This line causes the PWM signal to start.

The programmer should always verify that the PACT clock prescale value allows enough time slots for the entire Command/Definition area. In this example four time slots are required, one for each standard compare command and two for the virtual timer definition. The prescale value of five gives 12 time slots, more than enough for this application.

## PWM Example

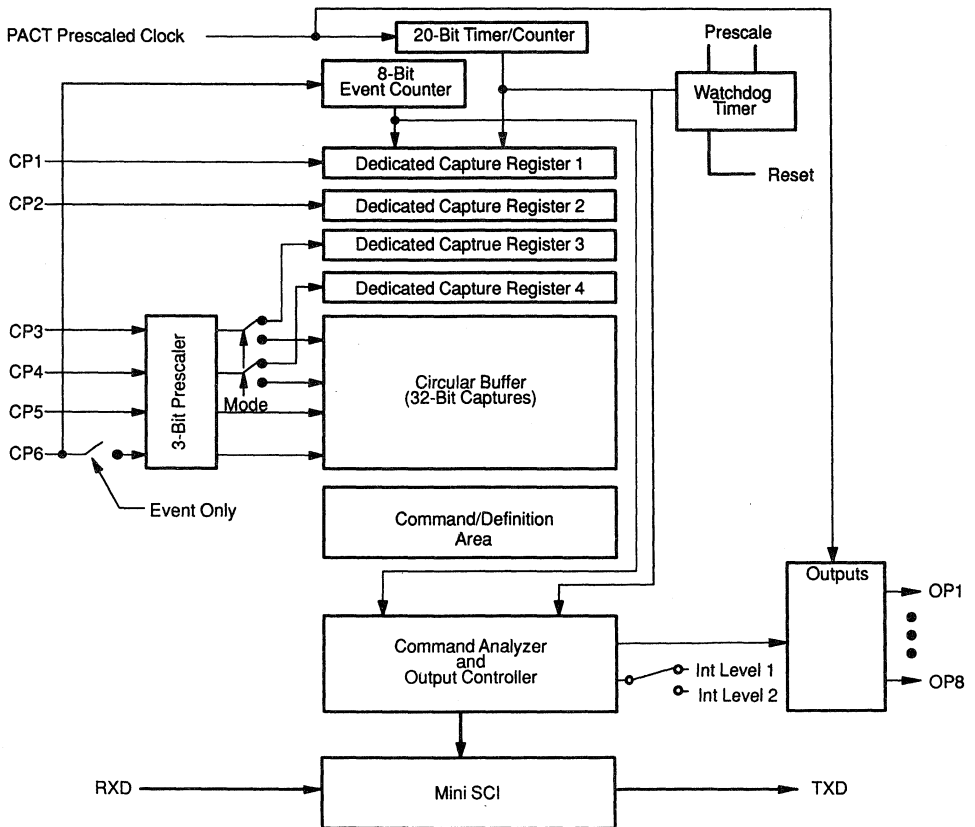
---

```
0001 ;This is an example program to do PWM using the PACT module
0002     .include "PACT.H"
0003
0004 ;MACRO DESCRIPTION
0005 ;stdcmp <compare value>,<pin>,<actions>
0006 ;virtmr <period>,<actions>,<initial timer value>
0007
0008     .sect "pact",7800h
0009 ;PACT instructions to do PWM
0010 table stdcmp 0,0,nxt_def           ;dummy cmd, next line=def
0001 #     .byte 0,0,1,0_
0011 virtmr 1000,enable                ;period = 1000 uSec
0001 #     .byte 0,0,52,31
0012 stdcmp 800,op1,opp_act|enable;80% duty, pin 1
0001 #     .byte 32,3,0,10
0013 len     .equ    $-table
0014
0015     .text    6000h
0016 cmd_st .equ 0EBh
0017 start mov #7,P04F                ;disable the watchdog
0018 ;copy PACT commands/def. into ram
0019     mov     #len,b                ;length of cmd/def area
0020     movw   #(cmd_st-len+1),r3     ;R2:R3 points to area
0021 loop  mov  table-1(b),a
0022     mov   a,@r3
0023     inc  r3
0024     djnz b,loop
0025
0026 ;set up the peripheral file
0027     mov   #07,p04f                ;set to mode B
0028     mov   #cmd_st,p041            ;cmd/def start at 0ebh
0029     mov   #(cmd_st-len+1),p042    ;cmd/def end = 0E0h
0030 ;set prescale to 5, 1 usec res, enable cmd/def area
0031     mov   #034h,p040
0032
0033 ; PWM running without processor intervention
0034     idle
0035     .end
```

## 12.14 PACT Block Diagram

Figure 12–11 is a block diagram of the PACT module. It shows the major functional blocks, inputs, and outputs. This module is controlled not only by the peripheral file but also by the defined areas/contents of the dual-port RAM. The dual-port RAM is located between 0080h and 00FFh (inclusive) on the memory map.

Figure 12–11. PACT Block Diagram



## 12.15 Peripheral Frame Control Registers

Peripheral frame 4 is used for functions related to the PACT module. Peripheral frame 4 is located from address 1040h to 104Fh. The sixteen bytes within the frame are assigned the functions shown below:

---

**Note:**

Be careful using the AND, OR, XOR, CMPBIT, SBIT0 or SBIT1 instruction to modify any of these registers that contain status flags. The Read/Modify/Write nature of these instructions may inadvertently clear an interrupt flag that was set between the read and the write cycles. If the state of the non-flag bits is known, the MOV #n1,Pn2 instruction can be used. If the state of the non-flag bits is not known, a sequence similar to the example shown below should be used.

```
;Clearing an interrupt flag
MOV    P04n,A
OR     #flag_mask,A    ;set all flag bits to one
AND    #desired_flag,A ;clear the desired flag bit
MOV    A,P04n
```

---

PERIPHERAL FILE FRAME 4: PACT CONTROL REGISTERS

ADDR	PF	BIT 7	BIT 6	BIT 5	BIT 4	BIT 3	BIT 2	BIT 1	BIT 0	
1040h	040	DEFTIM OVRFL INT ENA	DEFTIM OVRFL INT FLAG	CMD/DEF AREA ENA	PACT MODE SELECT	PACT PRE- SCALE SELECT 1	PACT PRE- SCALE SELECT 2	PACT PRE- SCALE SELECT	PACT PRE- SCALE SELECT 0	PACTSCR
1041h	041	CMD/DEF AREA INT ENA	—	CMD/DEF AREA START BIT 5	CMD/DEF AREA START BIT 4	CMD/DEF AREA START BIT 3	CMD/DEF AREA START BIT 2	—	—	CDSTART
1042h	042	—	CMD/DEF AREA END BIT 6	CMD/DEF AREA END BIT 5	CMD/DEF AREA END BIT 4	CMD/DEF AREA END BIT 3	CMD/DEF AREA END BIT 2	—	—	CDEND
1043h	043	—	—	BUFFER POINTER BIT 5	BUFFER POINTER BIT 4	BUFFER POINTER BIT 3	BUFFER POINTER BIT 2	BUFFER POINTER BIT 1	—	BUPPTR
1044h	044	RESERVED								
1045h	045	PACT RXRDY	PACT TXRDY	PACT PARITY	PACT FE	PACT SCI RX INT ENA	PACT SCI TX INT ENA	—	PACT SCI SW RESET	SCICTLP
1046h	046	PACT RXDT7	PACT RXDT6	PACT RXDT5	PACT RXDT4	PACT RXDT3	PACT RXDT2	PACT RXDT1	PACT RXDT0	RXBUFP
1047h	047	PACT TXDT7	PACT TXDT6	PACT TXDT5	PACT TXDT4	PACT TXDT3	PACT TXDT2	PACT TXDT1	PACT TXDT0	TXBUFP
1048h	048	PACT OP8 STATE	PACT OP7 STATE	PACT OP6 STATE	PACT OP5 STATE	PACT OP4 STATE	PACT OP3 STATE	PACT OP2 STATE	PACT OP1 STATE	OPSTATE
1049h	049	CMD/DEF INT 7 FLAG	CMD/DEF INT 6 FLAG	CMD/DEF INT 5 FLAG	CMD/DEF INT 4 FLAG	CMD/DEF INT 3 FLAG	CMD/DEF INT 2 FLAG	CMD/DEF INT 1 FLAG	CMD/DEF INT 0 FLAG	CDFLAGS
104Ah	04A	CP2 INT ENA	CP2 INT FLAG	CP2 CAPT RISING EDGE	CP2 CAPT FALLING EDGE	CP1 INT ENA	CP1 INT FLAG	CP1 CAPT RISING EDGE	CP1 CAPT FALLING EDGE	CPCTL1
104Bh	04B	CP4 INT ENA	CP4 INT FLAG	CP4 CAPT RISING EDGE	CP4 CAPT FALLING EDGE	CP3 INT ENA	CP3 INT FLAG	CP3 CAPT RISING EDGE	CP3 CAPT FALLING EDGE	CPCTL2
104Ch	04C	CP6 INT ENA	CP6 INT FLAG	CP6 CAPT RISING EDGE	CP6 CAPT FALLING EDGE	CP5 INT ENA	CP5 INT FLAG	CP5 CAPT RISING EDGE	CP5 CAPT FALLING EDGE	CPCTL3
104Dh	04D	BUFFER HALF/ FULL INT ENA	BUFFER HALF/ FULL INT FLAG	INPUT CAPT PRE- SCALE SELECT 3	INPUT CAPT PRE- SCALE SELECT 2	INPUT CAPT PRE- SCALE SELECT 1	CP6 EVENT ONLY	EVENT COUNTER SW RESET	OP SET / CLR SELECT	CPPRE
104Eh	04E	WATCHDOG RESET KEY								WDRST
104Fh	04F	PACT STEST	—	PACT GROUP 1 PRIORITY	PACT GROUP 2 PRIORITY	PACT GROUP 3 PRIORITY	PACT MODE SELECT	PACT WD PRE- SCALE SELECT 1	PACT WD PRE- SCALE SELECT 0	PACTPRI

## 12.15.1 Setup Control Register

Setup Control Register (PACTSCR)  
[Memory Address - 1040h]

BIT#-	7	6	5	4	3	2	1	0
P040	DEFTIM OVRFL INT ENA	DEFTIM OVRFL INT FLAG	CMD/DEF AREA ENA	FAST MODE SELECT	PACT PRE- SCALE SELECT3	PACT PRE- SCALE SELECT2	PACT PRE- SCALE SELECT1	PACT PRE- SCALE SELECT0
	RW-0	RC-0	RW-0	RP-0	RP-0	RP-0	RP-0	RP-0

R = Read, P = Privileged Write, C = Clear, -n-Value after reset

Bit 0 – 3 - **PACT PRESCALE SELECT 0 – 3.**

These four bits select a prescaler divide rate for the PACT module. These bits specify the divide of the system clock from +2 to +16. This gives 15 possible choices. The actual divide rate is also determined by the value of the FAST MODE SELECT bit. The possible combinations are shown below the bit description of the FAST MODE SELECT bit.

Bit 4 - **FAST MODE SELECT.**

This bit determines if the system clock is divided by 8 before entering into the 4-bit prescale. This bit as well as the PACT PRESCALE SELECT 0–3 bits, determines the time base for the PACT module. The possible combinations are shown below.

Divide Rate		
PACT Prescale Select	Fast Mode Select	
3 2 1 0	1	0
0 0 0 0	2	16
0 0 0 1	2	16
0 0 1 0	3	24
0 0 1 1	4	32
0 1 0 0	5	40
0 1 0 1	6	48
0 1 1 0	7	56
0 1 1 1	8	64
1 0 0 0	9	72
1 0 0 1	10	82
1 0 1 0	11	88
1 0 1 1	12	96
1 1 0 0	13	104
1 1 0 1	14	112
1 1 1 0	15	120
1 1 1 1	16	128

Bit 5 - **CMD/DEF AREA ENA.** Command and Definition Area Enable.

This bit determines if the command/definition area of the dual-port RAM is enabled. This allows the PACT module to use this area for commands and definitions.

0 = command/definition area is ignored.

1 = enables the commands and definitions.

- Bit 6 - **DEFTIM OVRFL INT FLAG.** Default Timer Overflow Interrupt Flag.  
This bit indicates the status of the PACT Default Timer Overflow Interrupt. This bit is cleared by reset or by writing a zero to it. This bit is set by overflow or when the timer is cleared.
- 0 = Default Timer Overflow interrupt inactive.  
1 = Default Timer Overflow interrupt pending.
- Bit 7 - **DEFTIM OVRFL INT ENA.** Default Timer Overflow Interrupt Enable.  
This bit controls the Default Timer Overflow interrupting capability.
- 0 = Disable Interrupt.  
1 = Enable Interrupt.

## 12.15.2 Command/Definition Area Start Register

**Command/Definition Area Start Register (CDSTART)  
[Memory Address – 1041h]**

BIT#-	7	6	5	4	3	2	1	0
P041	CMD/DEF AREA INT ENA	—	CMD/DEF AREA START BIT 5	CMD/DEF AREA START BIT 4	CMD/DEF AREA START BIT 3	CMD/DEF AREA START BIT 2	—	—
	RW-0		RW-0	RW-0	RW-0	RW-0		

R = Read, P = Priviledged Write, C = Clear, – n = Value after reset

Bit 0, 1 - Reserved. Read data is indeterminate.

Bit 2 – 5 - **CMD/DEF AREA START 2 – 5.** Command and Definition Area Start bits 2 – 5  
These bits define the start address of the Command / Definition Area. There are 16 possible locations for the Command /Definition Area Start. The address is the same as if you consider bits 7, 6, 1, and 0 of this register to be set as equal to 1. A table of the bits and the corresponding address is shown below.

CMD/DEF Area Start Bit				CMD/DEF Area Start		Notes
5	4	3	2	Address	Register	
0	0	0	0	00C3h	R0C3	
0	0	0	1	00C7h	R0C7	
0	0	1	0	00CBh	R0CB	
0	0	1	1	00CFh	R0CF	
0	1	0	0	00D3h	R0D3	
0	1	0	1	00D7h	R0D7	
0	1	1	0	00DBh	R0DB	
0	1	1	1	00DFh	R0DF	
1	0	0	0	00E3h	R0E3	
1	0	0	1	00E7h	R0E7	
1	0	1	0	00EBh	R0EB	
1	0	1	1	00EFh	R0EF	Note
1	1	0	0	00F3h	R0F3	Note
1	1	0	1	00F7h	R0F7	Note
1	1	1	0	00FBh	R0FB	Note
1	1	1	1	00Fh	R0FF	Invalid

**Note:** Use these values with caution. This area is used by the input capture pins.

Bit 6 - Reserved. Read data is indeterminate.

Bit 7 - **CMD/DEF AREA INT ENA.** Command and Definition Area Interrupt Enable  
This bit enables interrupts from the Command / Definition Area.

0 = Disable Interrupt.  
1 = Enable Interrupt.



### 12.15.3 Command/Definition Area End Register

**Command/Definition Area End Register (CDEND)**  
[Memory Address – 1042h]

BIT#-	7	6	5	4	3	2	1	0
P042	—	CMD/DEF AREA END BIT 6	CMD/DEF AREA END BIT 5	CMD/DEF AREA END BIT 4	CMD/DEF AREA END BIT 3	CMD/DEF AREA END BIT 2	—	—
		RW-0	RW-0	RW-0	RW-0	RW-0		

R = Read, W = Write, – n = Value after reset

Bit 0, 1 - Reserved. Read data is indeterminate.

Bit 2 – 6 - **CMD/DEF AREA END 2 – 6.** Command and Definition Area End bits 2 – 6 These bits define the end address of the Command / Definition Area. There are 32 possible locations for the Command /Definition Area End. The address is the same as if you consider bit 7 of this register to be set as equal to 1, and bit 1 and bit 0 to be set equal to 0. A table of the bits and the corresponding address is shown below.

CMD/DEF AREA END BIT					CMD/DEF END	
6	5	4	3	2	Address	Register
0	0	0	0	0	0080h	R080
0	0	0	0	1	0084h	R084
0	0	0	1	0	0088h	R088
0	0	0	1	1	008Ch	R08C
0	0	1	0	0	0090h	R090
0	0	1	0	1	0094h	R094
0	0	1	1	0	0098h	R098
0	0	1	1	1	009Ch	R09C
0	1	0	0	0	00A0h	R0A0
0	1	0	0	1	00A4h	R0A4
0	1	0	1	0	00A8h	R0A8
0	1	0	1	1	00ACh	R0AC
0	1	1	0	0	00B0h	R0B0
0	1	1	0	1	00B4h	R0B4
0	1	1	1	0	00B8h	R0B8
0	1	1	1	1	00BCh	R0BC
1	0	0	0	0	00C0h	R0C0
1	0	0	0	1	00C4h	R0C4
1	0	0	1	0	00C8h	R0C8
1	0	0	1	1	00CCh	R0CC
1	0	1	0	0	00D0h	R0D0
1	0	1	0	1	00D4h	R0D4
1	0	1	1	0	00D8h	R0D8
1	0	1	1	1	00DCh	R0DC
1	1	0	0	0	00E0h	R0E0
1	1	0	0	1	00E4h	R0E4
1	1	0	1	0	00E8h	R0E8
1	1	0	1	1	00ECh	R0EC
1	1	1	0	0	00F0h	R0F0
1	1	1	0	1	00F4h	R0F4
1	1	1	1	0	00F8h	R0F8
1	1	1	1	1	00FCh	R0FC

Bit 7 - Reserved. Read data is indeterminate.

### 12.15.4 Buffer Pointer Register

**Buffer Pointer Register (BUFPTR)**  
**[Memory Address – 1043h]**

BIT#-	7	6	5	4	3	2	1	0
P043	—	—	BUFFER POINTER BIT 5	BUFFER POINTER BIT 4	BUFFER POINTER BIT 3	BUFFER POINTER BIT 2	BUFFER POINTER BIT 1	—
			RW-0	RW-0	RW-0	RW-0	RW-0	
			R = Read, W = Write,		- n = Value after reset			

Bit 0 - Reserved. Read data is indeterminate.

Bit 1 – 5 - **BUFFER POINTER BIT 1 – 5.** Buffer Pointer Bit 1 – 5

These bits define the address of the Buffer Pointer. The buffer pointer points to the next available address in the circular buffer. There are 32 possible locations for the Buffer Pointer to address. These addresses are the same as if you consider this register where bit 7 and bit 6 of this register to be set as equal to 1, and bit 0 to be set equal to 0. A table of the bits and the corresponding address is shown below.

Buffer Pointer Bit					Buffer Pointer	
5	4	3	2	1	Address	Register
0	0	0	0	0	00C0h	ROC0
0	0	0	0	1	00C2h	ROC2
0	0	0	1	0	00C4h	ROC4
0	0	0	1	1	00C6h	ROC6
0	0	1	0	0	00C8h	ROC8
0	0	1	0	1	00CAh	ROCA
0	0	1	1	0	00CCh	ROCC
0	0	1	1	1	00CEh	ROCE
0	1	0	0	0	00D0h	ROD0
0	1	0	0	1	00D2h	ROD2
0	1	0	1	0	00D4h	ROD4
0	1	0	1	1	00D6h	ROD6
0	1	1	0	0	00D8h	ROD8
0	1	1	0	1	00DAh	RODA
0	1	1	1	0	00DCh	RODC
0	1	1	1	1	00DEh	RODE
1	0	0	0	0	00E0h	ROE0
1	0	0	0	1	00E2h	ROE2
1	0	0	1	0	00E4h	ROE4
1	0	0	1	1	00E6h	ROE6
1	0	1	0	0	00E8h	ROE8
1	0	1	0	1	00EAh	ROEA
1	0	1	1	0	00ECh	ROEC
1	0	1	1	1	00EEh	ROEE
1	1	0	0	0	00F0h	ROF0
1	1	0	0	1	00F2h	ROF2
1	1	0	1	0	00F4h	ROF4
1	1	0	1	1	00F6h	ROF6
1	1	1	0	0	00F8h	ROF8
1	1	1	0	1	00FAh	ROFA
1	1	1	1	0	00FCh	ROFC
1	1	1	1	1	00FEh	ROFE

Bit 6, 7 - Reserved. Read data is indeterminate.

## 12.15.5 PACT-SCI Control Register

**PACT-SCI Control Register (SCICTLP)**  
[Memory Address – 1045h]

BIT#-	7	6	5	4	3	2	1	0
P045	PACT RXRDY	PACT TXRDY	PACT PARITY	PACT FE	PACT SCI RX INT ENA	PACT SCI TX INT ENA	—	PACT SCI SW RESET
	RC-0	R-1	R-0	RC-0	RW-0	RW-0		RW-0

R = Read, W = Write, C = Clear, – n = Value after reset

- Bit 0 - **PACT SCI SW RESET.** PACT SCI Software Reset.  
This bit causes the SCI into a software RESET state when set. This bit must be cleared to allow the SCI to function. This bit is used to set-up the parameters of the SCI by disabling its function.  
0 = SCI in operating mode  
1 = SCI in software RESET mode.
- Bit 1 - Reserved. Read data is indeterminate.
- Bit 2 - **PACT SCI TX INT ENA.** PACT SCI Transmit Interrupt Enable  
This bit enables the interrupt to occur when the transmit buffer is empty.  
0 = Do not generate an interrupt when the Transmit Buffer is empty  
1 = Generate an interrupt when the Transmit Buffer is empty
- Bit 3 - **PACT SCI RX INT ENA.** PACT SCI Receive Interrupt Enable  
This bit enables the interrupt to occur when the receive buffer is full.  
0 = Do not generate an interrupt when the Receive Buffer is full  
1 = Generate an interrupt when the Receive Buffer is full
- Bit 4 - **PACT FE.** PACT Framing Error.  
This bit is a flag to show that a framing error was detected. This bit will remain set until cleared by a PACT SCI software reset, a system reset, or by writing a zero to it.  
0 = No framing error  
1 = Framing Error was detected.
- Bit 5 - **PACT PARITY.** PACT Receive Data Parity Bit.  
This bit is set as the result of the incoming parity calculation. To perform a parity check on incoming data this bit is compared to a 0 or 1 for even or odd parity.  
0 = Received data was even parity.  
1 = Received data was odd parity.
- Bit 6 - **PACT TXRDY.** PACT Transmit Ready.  
This bit shows when the transmit buffer is empty. This bit is set by a system reset, the PACT SCI software reset or when the SCI TX DATA Register has been shifted out.  
0 = Transmit Buffer is full  
1 = Transmit Buffer is empty
- Bit 7 - **PACT RXRDY.** PACT Receive Ready.  
This bit shows when the receive buffer is full. This bit is cleared by a system reset, the PACT SCI software reset, by writing a zero to it, or by reading the SCI RX DATA Register.  
0 = Receive Buffer is empty  
1 = Receive Buffer is full

### 12.15.6 PACT-SCI RX Data Register

**PACT-SCI RX Data Register (RXBUFP)**  
**[Memory Address – 1046h]**

BIT#-	7	6	5	4	3	2	1	0
P046	PACT RXDT7	PACT RXDT6	PACT RXDT5	PACT RXDT4	PACT RXDT3	PACT RXDT2	PACT RXDT1	PACT RXDT0
	R-0	R-0	R-0	R-0	R-0	R-0	R-0	R-0

R = Read, – n = Value after reset

Bit 0 – 7 - **PACT RXDT 0–7**. PACT Receive Data 0 – 7.  
 This register contains the data received by the SCI.

### 12.15.7 PACT-SCI TX Data Register

**PACT-SCI TX Data Register (TXBUFP)**  
**[Memory Address – 1047h]**

BIT#-	7	6	5	4	3	2	1	0
P047	PACT TXDT7	PACT TXDT6	PACT TXDT5	PACT TXDT4	PACT TXDT3	PACT TXDT2	PACT TXDT1	PACT TXDT0
	RW-0	RW-0	RW-0	RW-0	RW-0	RW-0	RW-0	RW-0

R = Read, W = Write, – n = Value after reset

Bit 0 – 7 - **PACT TXDT 0–7**. PACT Transmit Data 0 – 7.  
 This register contains the data to be transmitted by the SCI.

## 12.15.8 Output Pin 1 – 8 State Register

**Output Pin 1–8 State Register (OPSTATE)**  
[Memory Address – 1048h]

BIT#-	7	6	5	4	3	2	1	0
P048	PACT OP8 STATE	PACT OP7 STATE	PACT OP6 STATE	PACT OP5 STATE	PACT OP4 STATE	PACT OP3 STATE	PACT OP2 STATE	PACT OP1 STATE
	RW-0	RW-0	RW-0	RW-0	RW-0	RW-0	RW-0	RW-0

R = Read, W = Write, – n = Value after reset

Bit 0 – 7 -

**PACT OP STATE 1 – 8**. PACT OP Pin 1 – 8 State.

These bits reflect the current state of the output pins OP8 to OP1. Each bit is the actual state of the corresponding pin. Writing a 1 to any bit in this register will modify the corresponding output pin as determined by the OP SET/CLR SELECT bit (P04D.0).

Bit OPx Write	OP SET/CLR SELECT	Result
1	1	PACT OPx STATE = 1
1	0	PACT OPx STATE = 0
0	x	PACT OPx STATE remains unchanged

On RESET all pins are initialized to the low state.

Example 1, if OP SET/CLR SELECT = 1

```
11001011  OP STATE Register
11110000  Write to OP STATE Register
-----
11111011  New value in OP STATE Register.
```

Example 2, if OP SET/CLR SELECT = 0

```
11001011  OP STATE Register
11110000  Write to OP STATE Register
-----
00001011  New value in OP STATE Register.
```

## 12.15.9 Command/Definition Entry Flags Register

**Command/Definition Entry Flags Register (CDFLAGS)**  
[Memory Address – 1049h]

BIT#-	7	6	5	4	3	2	1	0
P049	CMD/DEF INT 7 FLAG	CMD/DEF INT 6 FLAG	CMD/DEF INT 5 FLAG	CMD/DEF INT 4 FLAG	CMD/DEF INT 3 FLAG	CMD/DEF INT 2 FLAG	CMD/DEF INT 1 FLAG	CMD/DEF INT 0 FLAG
	RC-0	RC-0	RC-0	RC-0	RC-0	RC-0	RC-0	RC-0

R = Read, C = Clear, – n = Value after reset

Bit 0 – 7 - **CMD/DEF INT 0 – 7 FLAG.** Command/Definition Interrupt 0 – 7 Flag.

These bits are the interrupt flags for the Command / Definition Area. If an interrupt has been enabled in a 4 byte command or definition then the appropriate bit in this register will be set when the interrupt conditions are met. The actual bit set is determined by the command or definition's place in the Command/Definition Area. For example, bit 0 is set when Entry 0, or 8, etc.(mod 8), is executed. A command or definition entry number refers to its place in memory. The command at the highest memory address is the first one evaluated and is ENTRY 0. Its address is defined by register CDSTART. The Program must clear this bit in the interrupt service routine to disable the interrupt request.

These flags are not affected by the CMD/DEF AREA INT ENA bit (CDSTART.7).

CMD/DEF INT FLAG SET	Command Or Definition Entry That Generated Interrupt Request
CMD/DEF INT 0 FLAG	ENTRY mod 8 = 0
CMD/DEF INT 1 FLAG	ENTRY mod 8 = 1
CMD/DEF INT 2 FLAG	ENTRY mod 8 = 2
CMD/DEF INT 3 FLAG	ENTRY mod 8 = 3
CMD/DEF INT 4 FLAG	ENTRY mod 8 = 4
CMD/DEF INT 5 FLAG	ENTRY mod 8 = 5
CMD/DEF INT 6 FLAG	ENTRY mod 8 = 6
CMD/DEF INT 7 FLAG	ENTRY mod 8 = 7

## 12.15.10 Setup CP Control Register 1

Setup CP Control Register 1 (CPCTL1)  
[Memory Address – 104Ah]

BIT#-	7	6	5	4	3	2	1	0
P04A	CP2 INT ENA	CP2 INT FLAG	CP2 CAPT RISING EDGE	CP2 CAPT FALLING EDGE	CP1 INT ENA	CP1 INT FLAG	CP1 CAPT RISING EDGE	CP1 CAPT FALLING EDGE
	RW-0	RC-0	RW-0	RW-0	RW-0	RC-0	RW-0	RW-0

R = Read, W = Write, C = Clear, - n = Value after reset

- Bit 0 - **CP1 CAPT FALLING EDGE.** CP1 Capture Falling Edge.  
This bit selects the falling edge on pin CP1 to cause a timer capture. See the table following the next bit description for all possible combinations
- Bit 1 - **CP1 CAPT RISING EDGE.** CP1 Capture Rising Edge.  
This bit selects the rising edge on pin CP1 to cause a timer capture. See the following table for all possible combinations.

CPx CAPT Rising Edge	CPx CAPT Falling Edge	Capture On Selected Edges
0	0	Disables captures
0	1	Captures on Falling Edges Only
1	0	Captures on Rising Edges Only
1	1	Captures on both Rising and Falling Edges

- Bit 2 - **CP1 INT FLAG.** CP1 Interrupt Flag.  
This bit indicates that the selected edge has occurred on pin CP1. This bit must be cleared by the program during an interrupt routine when CP1 INT ENA is set.  
0 = Capture interrupt from selected edge of CP1 inactive  
1 = Capture interrupt from selected edge of CP1 pending
- Bit 3 - **CP1 INT ENA.** CP1 Interrupt Enable.  
This bit enables the interrupt when the selected edge occurs on pin CP1.  
0 = Disable Interrupt.  
1 = Enable Interrupt.
- Bit 4 - **CP2 CAPT FALLING EDGE.** CP2 Capture Falling Edge.  
This bit selects the falling edge on pin CP2 to cause a timer capture. See the table following Bit 1 description for all possible combinations.
- Bit 5 - **CP2 CAPT RISING EDGE.** CP2 Capture Rising Edge.  
This bit selects the rising edge on pin CP2 to cause a timer capture. See the table following Bit 1 description for all possible combinations.

- Bit 6 - **CP2 INT FLAG.** CP2 Interrupt Flag.  
This bit indicates that the selected edge has occurred on pin CP2. This bit must be cleared by the program during an interrupt routine when CP2 INT ENA is set.
- 0 = Capture interrupt from selected edge of CP2 inactive
  - 1 = Capture interrupt from selected edge of CP2 pending
- Bit 7 - **CP2 INT ENA.** CP2 Interrupt Enable.  
This bit enables the interrupt when the selected edge occurs on pin CP2.
- 0 = Disable Interrupt.
  - 1 = Enable Interrupt.



## 12.15.11 Setup CP Control Register 2

Setup CP Control Register 2 (CPCTL2)  
[Memory Address – 104Bh]

BIT#-	7	6	5	4	3	2	1	0
P04B	CP4 INT ENA	CP4 INT FLAG	CP4 CAPT RISING EDGE	CP4 CAPT FALLING EDGE	CP3 INT ENA	CP3 INT FLAG	CP3 CAPT RISING EDGE	CP3 CAPT FALLING EDGE
	RW-0	RC-0	RW-0	RW-0	RW-0	RC-0	RW-0	RW-0

R = Read, W = Write, C = Clear, - n = Value after reset

- Bit 0 - **CP3 CAPT FALLING EDGE.** CP3 Capture Falling Edge.  
This bit selects the falling edge on pin CP3 to cause a timer capture. See the table following the next bit description for all possible combinations
- Bit 1 - **CP3 CAPT RISING EDGE.** CP3 Capture Rising Edge.  
This bit selects the rising edge on pin CP3 to cause a timer capture. See the following table for all possible combinations.

CPx CAPT Rising Edge	CPx CAPT Falling Edge	Capture On Selected Edges
0	0	Disables captures
0	1	Captures on Falling Edges Only
1	0	Captures on Rising Edges Only
1	1	Captures on both Rising and Falling Edges

- Bit 2 - **CP3 INT FLAG.** CP3 Interrupt Flag.  
This bit indicates that the selected edge has occurred on pin CP3. This bit must be cleared by the program during an interrupt routine when CP3 INT ENA is set.  
0 = Capture interrupt from selected edge of CP3 inactive  
1 = Capture interrupt from selected edge of CP3 pending
- Bit 3 - **CP3 INT ENA.** CP3 Interrupt Enable.  
This bit enables the interrupt when the selected edge occurs on pin CP3.  
0 = Disable Interrupt.  
1 = Enable Interrupt.
- Bit 4 - **CP4 CAPT FALLING EDGE.** CP4 Capture Falling Edge.  
This bit selects the falling edge on pin CP4 to cause a timer capture. See the table following Bit 1 description for all possible combinations.
- Bit 5 - **CP4 CAPT RISING EDGE.** CP4 Capture Rising Edge.  
This bit selects the rising edge on pin CP4 to cause a timer capture. See the table following Bit 1 description for all possible combinations.

- Bit 6 - **CP4 INT FLAG.** CP4 Interrupt Flag.  
This bit indicates that the selected edge has occurred on pin CP4. This bit must be cleared by the program during an interrupt routine when CP4 INT ENA is set.
- 0 = Capture interrupt from selected edge of CP4 inactive  
1 = Capture interrupt from selected edge of CP4 pending
- Bit 7 - **CP4 INT ENA.** CP4 Interrupt Enable.  
This bit enables the interrupt when the selected edge occurs on pin CP4.
- 0 = Disable Interrupt.  
1 = Enable Interrupt.

### 12.15.12 Setup CP Control Register 3

Setup CP Control Register 3 (CPCTL3)  
[Memory Address – 104Ch]

BIT#-	7	6	5	4	3	2	1	0
P04C	CP6 INT ENA	CP6 INT FLAG	CP6 CAPT RISING EDGE	CP6 CAPT FALLING EDGE	CP5 INT ENA	CP5 INT FLAG	CP5 CAPT RISING EDGE	CP5 CAPT FALLING EDGE
	RW-0	RC-0	RW-0	RW-0	RW-0	RC-0	RW-0	RW-0

R = Read, W = Write, C = Clear, - n = Value after reset

- Bit 0 - **CP5 CAPT FALLING EDGE.** CP5 Capture Falling Edge.  
This bit selects the falling edge on pin CP5 to cause a timer capture. See the table following the next bit description for all possible combinations.
- Bit 1 - **CP5 CAPT RISING EDGE.** CP5 Capture Rising Edge.  
This bit selects the rising edge on pin CP1 to cause a timer capture. See the following table for all possible combinations.

CPx CAPT Rising Edge	CPx CAPT Falling Edge	Capture On Selected Edges
0	0	Disables captures
0	1	Captures on Falling Edges Only
1	0	Captures on Rising Edges Only
1	1	Captures on both Rising and Falling Edges

- Bit 2 - **CP5 INT FLAG.** CP5 Interrupt Flag.  
This bit indicates that the selected edge has occurred on pin CP5. This bit must be cleared by the program during an interrupt routine when CP5 INT ENA is set.  
0 = Capture interrupt from selected edge of CP5 inactive  
1 = Capture interrupt from selected edge of CP5 pending
- Bit 3 - **CP5 INT ENA.** CP5 Interrupt Enable.  
This bit enables the interrupt when the selected edge occurs on pin CP5.  
0 = Disable Interrupt.  
1 = Enable Interrupt.
- Bit 4 - **CP6 CAPT FALLING EDGE.** CP6 Capture Falling Edge.  
This bit selects the falling edge on pin CP6 to cause a timer capture. See the table following Bit 1 description for all possible combinations.
- Bit 5 - **CP6 CAPT RISING EDGE.** CP6 Capture Rising Edge.  
This bit selects the rising edge on pin CP6 to cause a timer capture. See the table following Bit 1 description for all possible combinations.

- Bit 6 - **CP6 INT FLAG.** CP6 Interrupt Flag.  
This bit indicates that the selected edge has occurred on pin CP6. This bit must be cleared by the program during an interrupt routine when CP6 INT ENA is set.
- 0 = Capture interrupt from selected edge of CP6 inactive  
1 = Capture interrupt from selected edge of CP6 pending
- Bit 7 - **CP6 INT ENA.** CP6 Interrupt Enable.  
This bit enables the interrupt when the selected edge occurs on pin CP6.
- 0 = Disable Interrupt.  
1 = Enable Interrupt.

## 12.15.13 CP Input Control Register

**CP Input Control Register (CPPRE)**  
**[Memory Address – 104Dh]**

BIT#-	7	6	5	4	3	2	1	0
P04D	BUFFER HALF/ FULL INT ENA	BUFFER HALF/ FULL INT FLAG	INPUT CAPT PRE- SCALE SELECT3	INPUT CAPT PRE- SCALE SELECT2	INPUT CAPT PRE- SCALE SELECT1	CP6 EVENT ONLY	EVENT COUNTER SW RESET	OP SET/CLR SELECT
	RW-0	RC-0	RW-0	RW-0	RW-0	RW-0	RW-0	RW-0

R = Read, W = Write, C = Clear, – n = Value after reset

- Bit 0 - OP SET/CLR SELECT.** Output Pin Set/Clear Write Function Select  
 This bit controls how the outputs OP1 to OP8 are set or cleared by software. When OP SET/CLR = 1, a write to P048 will cause the output pins corresponding to the locations that were written as 1 to be set in the high state. The output pins that corresponding to the locations that were written as 0 remain unchanged. When OP SET/CLR = 0, a write to P048 will cause the output pins corresponding to the locations that were written as 1 to be set in the low state. The output pins that corresponding to the locations that were written as 0 remain unchanged. This is further shown in the following table. See the example in Section 12.15.8.

Bit OPx WRITE	OP SET/CLR SELECT	Result
1	1	PACT OPx STATE = 1
1	0	PACT OPx STATE = 0
0	x	PACT OPx STATE remains unchanged

- Bit 1 - EVENT COUNTER SW RESET.** 8-Bit Event Counter Software Reset.  
 This bit resets the 8-bit event counter. When set the 8-bit counter is continuously cleared. This bit **MUST** be cleared to enable the event counter to operate.
- 0 = Event counter operating  
 1 = Event counter cleared
- Bit 2 - CP6 EVENT ONLY.** CP6 8-Bit Event Counter Input Only  
 This bit must be cleared to allow 32-bit captures triggered by CP6. This bit does not disable the 16-bit captures on event (CP6) when triggered by a COMMAND/DEFINITION area command.
- 0 = CP6 increments event counter and causes 32-bit captures.  
 1 = CP6 increments event counter only.

Bit 3 – 5 - **INPUT CAPT PRESCALE SELECT 1 – 3.** Input Capture Prescale Select 1 – 3  
 These pins set the prescaler rate for pins CP3 to CP6. They allow a divide rate of ÷1 to ÷8. The prescale rate does not affect the event counter.

INPUT CAPT PRESCALE SELECT			Divide Rate
3	2	1	
0	0	0	÷1
0	0	1	÷2
0	1	0	÷3
0	1	1	÷4
1	0	0	÷5
1	0	1	÷6
1	1	0	÷7
1	1	1	÷8

Bit 6 - **BUFFER HALF/FULL INT FLAG.** Buffer Half/Full Interrupt Flag  
 This bit is set when the circular buffer becomes half or completely full. It is cleared by writing a zero to this bit, or during RESET.

0 = Interrupt inactive  
 1 = Interrupt pending

Bit 7 - **BUFFER HALF/FULL INT ENABLE.** Buffer Half/Full Interrupt Enable  
 This bit determines whether or not the circular buffer can generate an interrupt on the half full and full buffer boundaries.

0 = Disable Interrupt  
 1 = Enable Interrupt

## 12.15.14 Global Function Control Register

Global Function Control Register (PACTPRI)  
[Memory Address – 104Fh]

BIT#-	7	6	5	4	3	2	1	0
P04F	PACT STEST	–	PACT GROUP 1 PRIOR- ITY	PACT GROUP 2 PRIOR- ITY	PACT GROUP 3 PRIOR- ITY	PACT MODE SELECT	PACT WD PRE- SCALE SELECT1	PACT WD PRE- SCALE SELECT0
	RP-0		RP-0	RP-0	RP-0	RP-0	RP-0	RP-0

R = Read, P = Priviledged Write, – n = Value after reset

- Bit 0, 1 - **PACT WD PRESCALE SELECT 0 – 1.** PACT Watchdog Prescale Select 0 – 1.  
These bits are used to select the watchdog time out rate. These bits are only writable during Privilege Mode (after RESET).

PACT WD PRESCALE SELECT 1	PACT WD PRESCALE SELECT 0	Options
0	0	Watchdog reset on Bit 9 of Default Timer
0	1	Watchdog reset on Bit 15 of Default Timer
1	0	Watchdog reset on Bit 19 of Default Timer
1	1	Disable Watchdog

- Bit 2 - **PACT MODE SELECT.** PACT Mode Select.  
This bit selects the mode for the PACT module to operate in.  
0 = PACT operates in MODE A  
1 = PACT operates in MODE B
- Bit 3 - **PACT GROUP 3 PRIORITY.** PACT Group 3 Priority Select.  
This bit assigns the interrupt priority level of the PACT Group 3 Interrupt vectors.  
0 = PACT Group 3 Interrupts are Level 1 (high priority) requests.  
1 = PACT Group 3 Interrupts are Level 2 (low priority) requests.
- Bit 4 - **PACT GROUP 2 PRIORITY.** PACT Group 2 Priority Select.  
This bit assigns the interrupt priority level of the PACT Group 2 Interrupt vectors.  
0 = PACT Group 2 Interrupts are Level 1 (high priority) requests.  
1 = PACT Group 2 Interrupts are Level 2 (low priority) requests.
- Bit 5 - **PACT GROUP 1 PRIORITY.** PACT Group 1 Priority Select.  
This bit assigns the interrupt priority level of the PACT Group 1 Interrupt vectors.  
0 = PACT Group 1 Interrupts are Level 1 (high priority) requests.  
1 = PACT Group 1 Interrupts are Level 2 (low priority) requests.

## *Peripheral Frame Control Registers*

---

- Bit 6 - Reserved. Read data is indeterminate.
- Bit 7 - **PACT STEST.**  
This bit must be cleared to ensure proper operation



Introduction	1
Assembly Language Instruction Set	13
TMS370 Family Devices	2
Design Aids	14
CPU and Memory Organization	3
Development Support	15
System and Digital I/O Configuration	4
Electrical Specifications	16
Interrupts and System Reset	5
Customer Information	17
EEPROM Modules	6
Appendices	A-H
Timer 1 Module	7
Timer 2 Module	8
Serial Communications Interface (SCI) Port	9
Serial Peripheral Interface (SPI) Module	10
Analog-to-Digital Converter Module	11
TMS370 Programmable Acquisition and Control Timer	12





### 13.1 Instruction Operation

The assembly language instruction set provides a convenient method of programming the CPU. Each TMS370 assembly language instruction converts directly to one machine operation and consists of a function mnemonic followed by zero to three operands. The mnemonic specifies the type of CPU operation while the operands indicate where the CPU can find or store data during an instruction execution. The type and combination of operands determine the actual opcode(s) for an instruction. The MOV instruction, for example, has 27 different options, each with its own opcode.

The typical syntax for TMS370 instructions consists of the function mnemonic followed by up to three operands. A typical two-operand instruction is shown below:

<u>MNEMONIC</u>	<u>SOURCE</u>	<u>DESTINATION</u>
ADD	#9,	R3

The example above can be read as: add the value "9" to the contents of register number 3 and place the result back into register number 3. The destination, therefore, also serves as a second source as well as being the final address of the result. This means that registers can be directly manipulated without having to use intermediate registers. Note that this instruction form differs from the "mnemonic-destination-source" arrangement used by some microprocessors.

The following example shows how the instruction above might appear in a complete program line.

<u>LABEL</u>	<u>INST.</u>	<u>OPERANDS</u>	<u>COMMENT</u>
XXXXX	ADD	R9, R3	; comment

There should be at least one space between each entry type. The LABEL and COMMENT entries are optional, and depending on which type of instruction is used, the OPERANDS column may be blank as well.

The 73 instructions are supported by 246 opcodes providing flexible control of CPU program flow. Some instructions such as CLRC and TEST A share the same opcode to aid the user in comprehending all of the functions of an opcode. There are instructions that use 16-bit opcodes, depending on the type of instruction and/or the addressing mode used. Several bit manipulation instructions are constructed by the assembler out of other instructions in order to simplify writing and enhance the readability of the program.

## 13.2 Addressing Modes

Each TMS370 assembly language instruction includes from zero to three operands. Each operand has an addressing mode. The addressing mode specifies how the CPU calculates the address of the data needed by the instruction. The power of the TMS370 is enhanced by the large number of addressing modes available. Table 13–1 shows the 14 addressing modes with a sample instruction and its execution.

**Table 13–1. Addressing Modes**

Addressing Mode	Example	Execution
General:		
Implied	LDSP	(B) → (SP)
Register	MOV R5,R4	(0005) → (0004)
Peripheral	MOV P025,A	(1025) → A
Immediate	ADD #123,R3	123 + (03) → (03)
PC Relative	JMP offset	PCN + offset → (PC)
Stack Pointer Relative	MOV 2(SP),A	(2 + (SP)) → (A)
Extended:		
Absolute Direct	MOV A,1234	(A) → (1234)
Absolute Indexed	MOV 1234(B),A	(1234 + (B)) → (A)
Absolute Indirect	MOV @R4,A	((R3:R4)) → (A)
Absolute Offset Indirect	MOV 12(R4),A	(12 + (R3:R4)) → (A)
Relative Direct	JMPL 1234	PCN + 1234 → (PC)
Relative Indexed	JMPL 1234(B)	PCN + 1234 + (B) → (PC)
Relative Indirect	JMPL @R4	PCN + (R3:R4) → (PC)
Relative Offset Indirect	JMPL 12(R4)	PCN + 12 + (R3:R4) → (PC)

**NOTE:** PCN = 16-bit address of next instruction.  
 (x) = Contents of memory at address x.  
 ((x)) = Contents of memory location designated by contents at address x.

As indicated in the table, there are 14 addressing modes divided into two classes: General, which uses an 8-bit addressing range, and Extended, which uses a 16-bit addressing range. A number of instructions use more than one addressing mode and several, such as the MOV instruction, are very versatile.

### 13.2.1 General Addressing Modes

Instructions using the **general addressing** modes have an eight bit range of operation, and therefore deal with the register file, peripheral file, or a nearby destination. The general addressing modes are implied, register, peripheral, immediate, program counter relative, and stack pointer relative. Most of these modes can use any register as a source and/or destination, preventing the bottleneck found on other microprocessors that use only one or two registers.

#### 13.2.1.1 Implied Addressing Mode

In the **implied addressing** mode, the instruction type alone determines where the data is to be found. The user does not have to specify the operands since they are inherently specified in the instruction. For example, the LDSP (Load Stack Pointer) instruction always copies the contents of the B register to the stack pointer register. Neither the source nor destination is explicitly stated because they are implied in the instruction itself. The instructions using the implied addressing mode are the CLRC, LDSP, RTS, RTI, SETC, STSP, EINT, EINTH, and EINTL instructions. Figure 13–1 shows an example of the implied addressing mode.

**Figure 13–1. Implied Addressing Mode**



### 13.2.1.2 Register Addressing Mode

The register file of the TMS370 consists of the first 256 bytes of memory. In the **register addressing** mode, instructions use a one byte value to specify an address (location) in the register file. Any location in the register file can be accessed in one memory cycle by instructions using this mode. **Extended addressing** modes take two cycles to access the register file. In register file addressing, the operand is stated by Rn, where n is the 8-bit address number. The address number may be a decimal (0–255) or hexadecimal (0–0FF) number. Hexadecimal numbers require a leading zero, but no suffix. Registers R0 and R1 of the register file are also known as registers A and B and are referenced as such by most instructions to reduce the size of the program. For example, the instruction `MOV A,B` uses one byte of code, while the instruction `MOV R3,R4` uses three bytes of code. Any register can be specified by a symbol that has been equated to that register. This is illustrated in the following example:

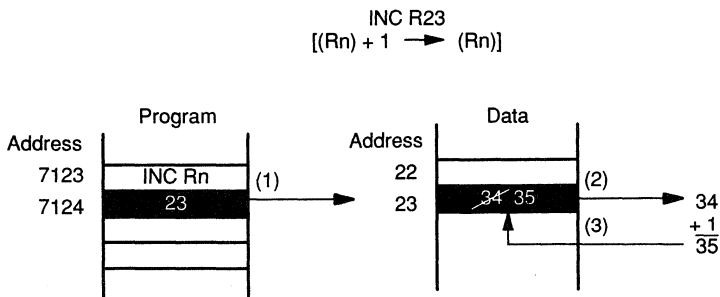
```

MOV   R16,R011  ;Move contents of 0010h to 0011h
CAT   .EQU R16   ;Equate register 16 to symbol CAT
DOG   .EQU R17   ;Equate register 17 to symbol DOG
MOV   CAT,DOG   ;Move contents of 0010h to 0011h

```

Note that the entry ".EQU" is an assembler directive, not an assembly language instruction. For more information on assembler directives, refer to the TMS370 Family Assembly Language Tools User's Guide. Figure 13–2 shows an example of the register addressing mode.

**Figure 13–2. Register Addressing Mode**



**Note:** Numbers in parentheses represent order of execution.

### 13.2.1.3 Peripheral Addressing Mode

The **peripheral addressing** mode is used for program control of the peripheral on-chip modules such as timers, interrupts, and I/O ports. A small amount of external memory can also be addressed as Peripheral file space from devices with bus expansion. The Peripheral file of the TMS370 is allocated 256 bytes of memory. Each Peripheral file register is accessed by an 8-bit operand designated as Pn, with n being either a decimal (0–255) or hexadecimal (00–FF) number. Hexadecimal numbers require a leading zero but no suffix. The CPU assumes the most significant byte of a peripheral address to be 010h. As described in register file addressing, the Pn designation may be substituted with a symbol using the equate (.EQU) assembler directive as shown in the example below.

the TMS370Cx50

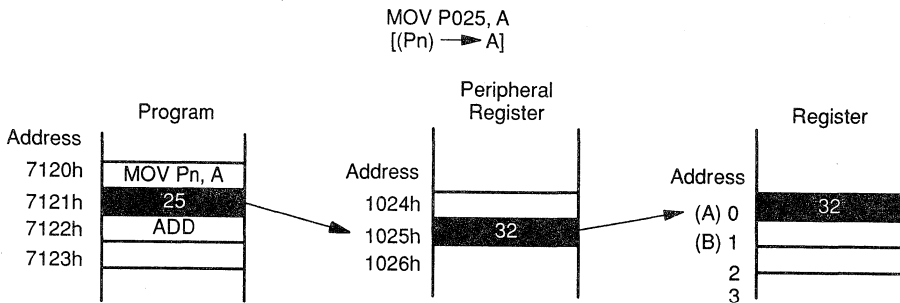
```

MOV    R16,P020    ;Move contents of 0010h to 1020h
CAT    .EQU  R16    ;Equate register 16 to symbol CAT
DOG    .EQU  P32    ;Equate peripheral file 32 to symbol DOG
MOV    CAT,DOG     ;Move contents of 0010h to 1020h

```

The use of designated symbols is optional, of course, but is particularly suited for the register and peripheral addressing modes. Figure 13–3 shows an example of peripheral file addressing.

**Figure 13–3. Peripheral Addressing Mode**





### 13.2.1.4 Immediate Addressing Mode

The **immediate addressing** mode uses a constant value as the operand immediately following the function mnemonic. This mode allows non-changing data to be incorporated into the instruction. The constant may be in the form of a decimal, hexadecimal, or symbolic label, but it is always preceded by the number sign (#). Hexadecimal numbers require both a leading numeric digit and the h suffix. Some examples of immediate addressing are as follows:

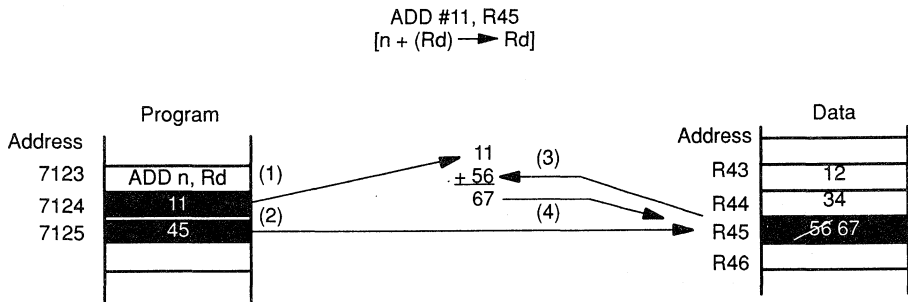
```

MOV    #0Fh,A           ;Store the value 15 in register A
MOV    #(3*54),R022     ;Store the value 162 at location 022h
CNT    .EQU 12          ;Equate 12 to symbol CNT
ADD    #CNT,R34         ;Add the value 12 to register 34, place
                        ;result in register 34.

```

Figure 13–4 illustrates an instruction using the immediate addressing mode.

**Figure 13–4. Immediate Addressing Mode**

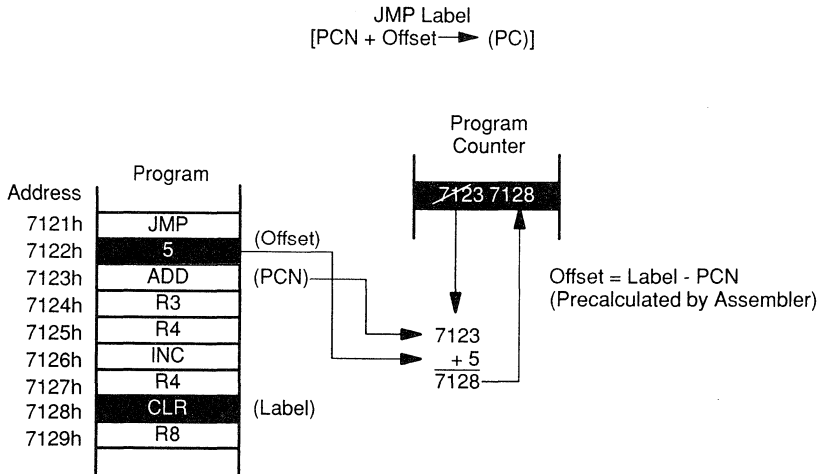


**Note:** Numbers in parentheses represent order of execution.

### 13.2.1.5 Program Counter Relative Addressing Mode

The **program counter relative addressing** mode adds an 8-bit signed offset to the address of the next instruction to produce the address of the successive instruction. The new address is placed in the program counter register. The range of the 8-bit offset is within 128 bytes before or 127 bytes after the instruction following the jump. When labels are used, the signed offset is automatically calculated by the assembler. The PCN is the location (address) of the next instruction. Figure 13–5 illustrates object code generated by a Jump instruction using the program counter relative addressing mode.

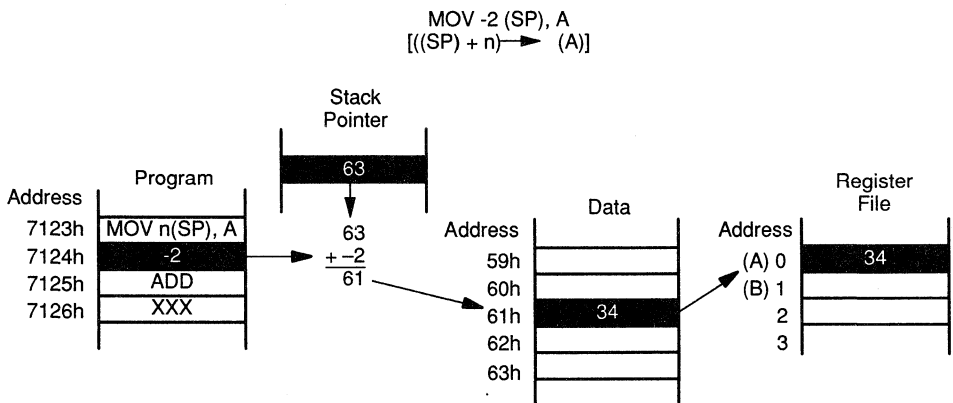
**Figure 13–5. Program Counter Relative Addressing Mode**



### 13.2.1.6 Stack Pointer Relative Addressing Mode

The **stack pointer relative addressing** mode adds an 8-bit signed constant to the existing 8-bit contents of the stack pointer register. The result is truncated to an 8-bit address of the data. The second operand in the stack pointer relative mode is always register A. This addressing mode is useful in accessing arguments that are passed to a subroutine on the stack. The programmer must insure that the resulting address location is within the implemented register file, because overflows or underflows will execute without warning. Only the CMP and MOV instructions use this mode. An example of stack relative addressing is as follows: *MOV -2(SP), A*. In this case, the value of  $-2$  plus the stack pointer equals the address of the data to be moved to register A. Figure 13–6 illustrates this instruction operation.

**Figure 13–6. Stack Pointer Relative Addressing Mode**



### 13.2.2 Extended Addressing Modes

The **extended addressing** modes provide sophisticated addressing capabilities of arrays, tables, and routine addresses. These modes allow the program to access data from anywhere in the memory. Extended addressing modes consist of four main types: direct, indirect, indexed, and offset indirect. Each of these four types can be subdivided into absolute and relative modes for a total of eight extended addressing modes.

**Extended absolute addressing** modes always use register A or the PC as one of the operands in generating a 16-bit address. The extended absolute addressing modes are used only by the Branch (BR), CALL, Compare (CMP), and Move (MOV) instructions. The BR and CALL instructions use these modes exclusively.

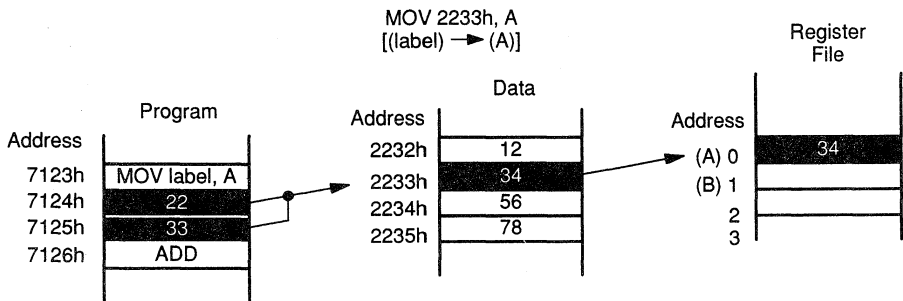
The **extended relative addressing** modes are similar to the extended absolute addressing modes but include the additional step of combining the operand with the program counter (PCN) value before placing the 16-bit address into the program counter. These modes are similar to the program counter relative mode. A 16-bit signed offset is used to calculate the successive instruction address. The successive instruction address is calculated at execution time using the signed 16-bit offset according to the instruction's addressing mode.

The extended relative addressing modes are useful in relocatable code since operation is based on the differences in address position instead of on the addresses themselves. This makes the extended relative addressing modes well suited for high level languages that often use position independent code. Extended relative addressing is used by the CALLR and JMPL instructions.

### 13.2.2.1 Direct Addressing Modes

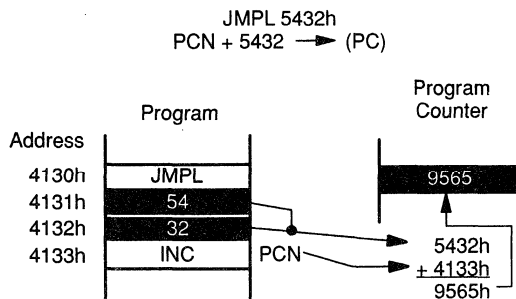
**Direct addressing** mode instructions use an address as the operand: The 16-bit address is written either as a constant value or a label, and immediately follows the opcode in the source code. The **absolute direct addressing** mode acts upon the address itself for operation as shown in Figure 13–7 below.

**Figure 13–7. Absolute Direct Addressing Mode**



The **relative direct addressing** mode (Figure 13–8) adds the address of the next instruction to the 16-bit operand to produce the address of the successive instruction. If a label is used in the instruction, the assembler automatically calculates the offset to use as the operand.

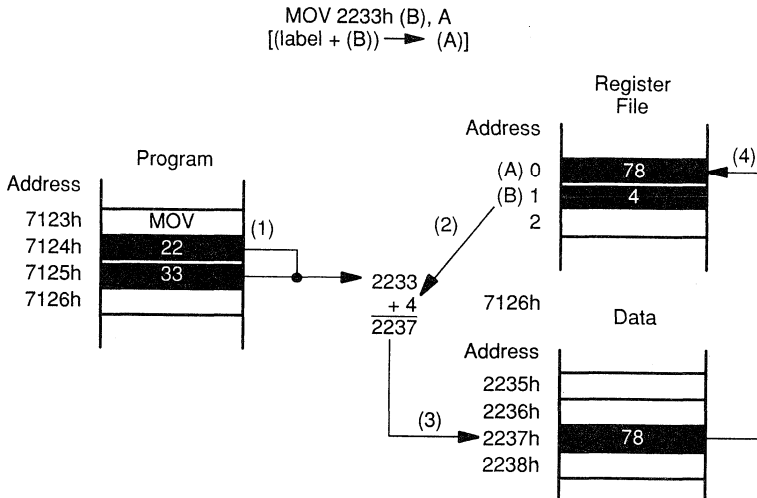
**Figure 13–8. Relative Direct Addressing Mode**



13.2.2.2 Indexed Addressing Modes

The absolute indexed addressing mode generates a 16-bit address by adding the unsigned contents of the B Register to a 16-bit unsigned constant. The assembly language statement for the indexed addressing modes contain the direct memory address written as a 16-bit value or a label, followed by a B in parentheses: MOV 1234(B), or MOV LABEL(B). The MOV and CMP instructions can use absolute indexed addressing to easily step through a small table or pick out a particular array value. The instructions CALL and BR can use this mode to execute code based on a decision table and the value in register B. Figure 13–9 illustrates how the object code produced by an instruction using this mode generates a 16-bit effective address.

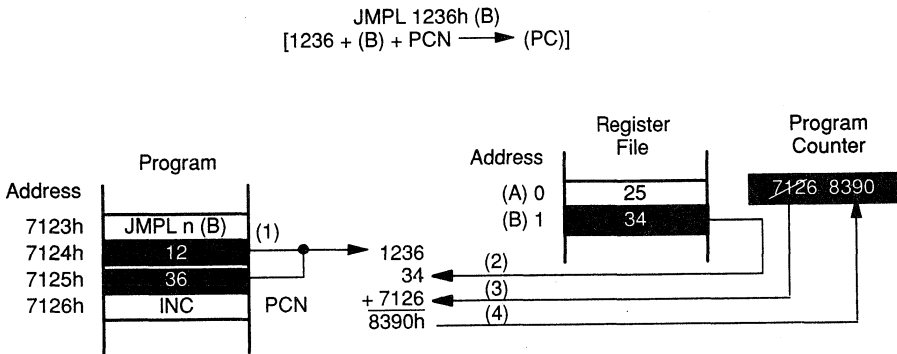
Figure 13–9. Absolute Indexed Addressing Mode



Note: Numbers in parentheses represent order of execution.

The **relative indexed addressing** mode includes the operation described above with the following additional step. The address of the next instruction is added to the sum of register B and the signed 16-bit constant offset, before producing the address of the next instruction as shown in Figure 13–10.

**Figure 13–10. Relative Indexed Addressing Mode**

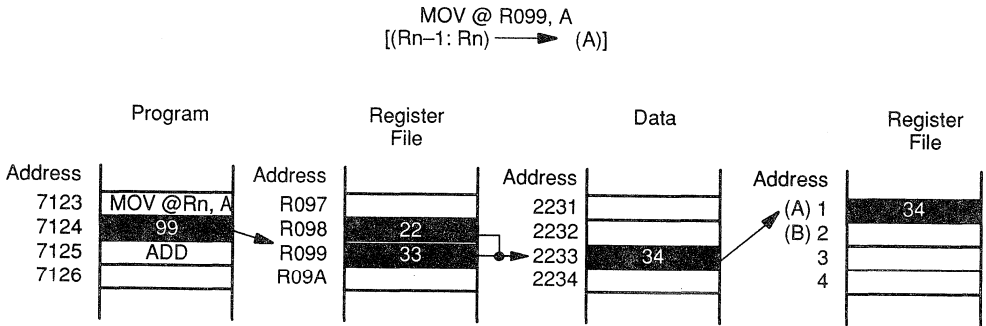


**Note:** Numbers in parentheses represent order of execution.

### 13.2.2.3 Indirect Addressing Modes

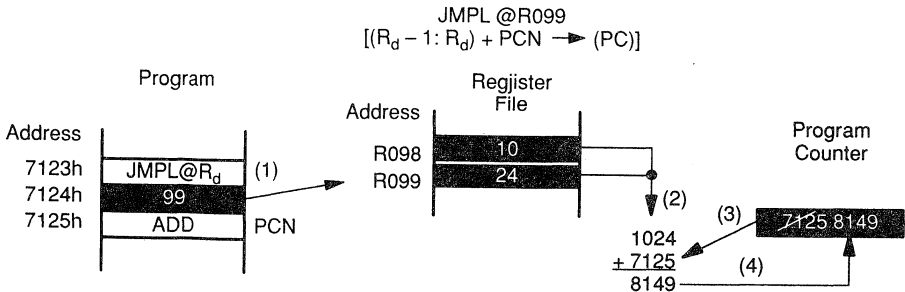
Instructions using the **indirect addressing** modes use the contents of a register pair as the 16-bit address of the data. The indirect register file address is written as a register number ( $R_n$ ) preceded by the commercial "at" (@) symbol. The LSB of the address is contained in  $R_n$ , and the MSB of the address is contained in the previous register ( $R_{n-1}$ ). The TMS370 can use any register pair as an indirect register. Figure 13–11 shows how the **absolute indirect addressing** mode uses the register pair itself in the calculation.

Figure 13–11. Absolute Indirect Addressing Mode



The **relative indirect addressing** mode (Figure 13–12) adds the address of the next instruction to the register pair contents before obtaining the destination address.

Figure 13–12. Relative Indirect Addressing Mode



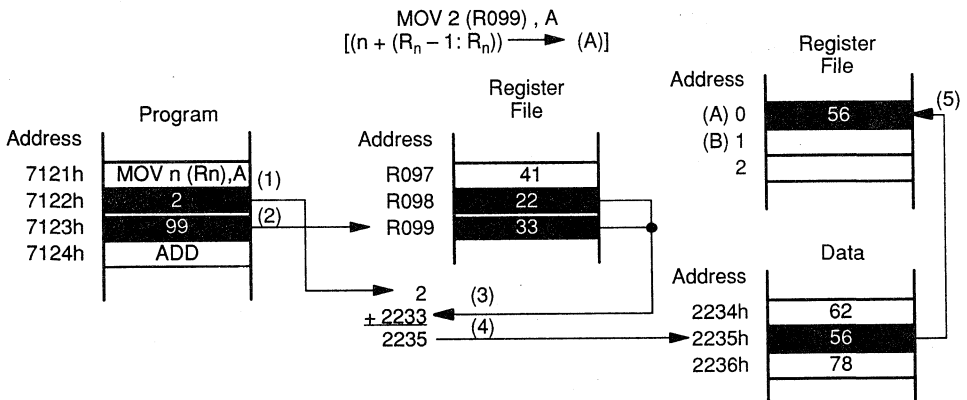
**Note:** Numbers in parentheses represent order of execution.



### 13.2.2.4 Offset Indirect Addressing Modes

The **offset indirect addressing** modes are similar to the indirect addressing modes previously described. The **absolute offset indirect addressing** mode generates a 16-bit address by adding an 8-bit signed offset to an address taken from a register pair. Offset indirect addressing is useful in stepping through tables or finding a particular value in a table by using two values to generate the address. Figure 13–13 illustrates how the object code produced by an instruction using the offset indirect addressing mode generates a 16-bit effective address.

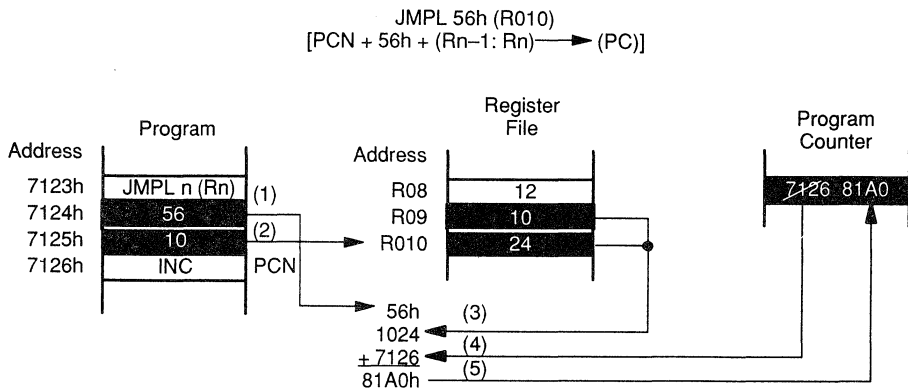
**Figure 13–13. Absolute Offset Indirect Addressing Mode**



**Note:** Numbers in parentheses represent order of execution.

The **relative offset indirect addressing** mode adds the address of the next instruction with the sum of the 8-bit signed offset and the register pair before obtaining the destination address.

**Figure 13–14. Relative Offset Indirect Addressing Mode**



**Note:** Numbers in parentheses represent order of execution.

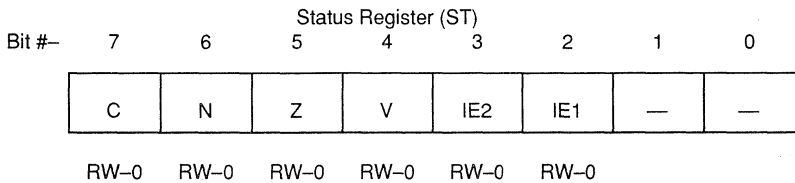
### 13.2.3 Additional Addressing Modes

There are some cases where the operation of an instruction does not fit into any of the previously described addressing modes. Some modes such as `MOVW #iop(B),Rpd` provide unique capabilities for table addressing. Other modes like the `LDST #iop8` give access to the status register bits (shown in Figure 13–15). The individual instruction description can be referenced for a list of that instruction's operations.

### 13.2.4 Status Register

Most of the instructions affect the bits in the status register. The status register is presented as a quick reference to aid in programming.

**Figure 13–15. Status Register (ST)**



## 13.3 Instruction Set Overview

The following tables provide a listing of the instruction set symbols, a listing of the instruction set itself including pertinent characteristics, and an opcode/instruction map.

**Table 13–2. TMS370 Symbol Definitions**

Symbol	Definition	Symbol	Definition
A	Register A or R0 in register file	B	Register B or R1 in register file
Rn	Register n of register file	Pn	Register n of peripheral file ( $0 \leq n \leq 255$ )
s	Source operand	d/D	Destination operand (8-bit/16-bit)
Rs	Source register in register file	Ps	Source register in peripheral file ( $0 \leq s \leq 255$ )
Rd	Destination register in register file	Pd	Destination register in peripheral file ( $0 \leq d \leq 255$ )
Rps	Source register pair	Rpd	Destination register pair
iop8	8-bit Immediate operand	iop16	16-bit Immediate operand
off8	8-bit Signed Offset	off16	16-bit Signed Offset
Rp	Register pair	label	16-bit label
ST	Status register	SP	Stack pointer
PC	Program Counter	PCN	16-bit address of next instruction
#	Immediate operand	@	Indirect addressing operand
MSB	Most significant byte	LSB	Least significant byte
MSb	Most significant bit	LSb	Least significant bit
cond	Condition	< >	Indicates an entry that must be typed in. For example, <label> indicates that a label must be entered. The brackets themselves are not entered.
→	Is assigned to	←	Becomes equal to
(x)	Contents of memory at address x.	((x))	Contents of memory location designated by contents at address x.
C	Carry flag	N	Sign flag
V	Overflow/borrow flag	Z	Zero flag
XADDR	16-bit address	name	symbol defined for a bit
Rname	symbol defined register bit	Pname	symbol defined peripheral bit

Table 13–3 lists all instruction formats, opcodes, byte lengths, cycles/instruction, operand types, status bits affected, and an operational description.

Table 13–3. TMS370 Family Instruction Overview

Mnemonic	Opcode	Bytes	Cycles $t_c$	Status C N Z V	Operation Description	
ADC	B,A	69	1	8	x x x x	(s) + (d) + (C) → (d) Add the source, destination, and carry bit together. Store at the destination address.
	Rs,A	19	2	7		
	Rs,B	39	2	7		
	Rs,Rd	49	3	9		
	#iop8,A	29	2	6		
	#iop8,B	59	2	6		
	#iop8,Rd	79	3	8		
ADD	B,A	68	1	8	x x x x	(s) + (d) → (d) Add the source and destination operands at the destination address.
	Rs,A	18	2	7		
	Rs,B	38	2	7		
	Rs,Rd	48	3	9		
	#iop8,A	28	2	6		
	#iop8,B	58	2	6		
	#iop8,Rd	78	3	8		
AND	A,Pd	83	2	9	0 x x 0	(s) AND (d) → (d) AND the source and destination operands together and store at the destination address.
	B,A	63	1	8		
	B,Pd	93	2	9		
	Rs,A	13	2	7		
	Rs,B	33	2	7		
	Rs,Rd	43	3	9		
	#iop8,A	23	2	6		
	#iop8,B	53	2	6		
	#iop8,Rd	73	3	8		
	#iop8,Pd	A3	3	10		
BR	label	8C	3	9	- - - -	XADDR → (PC) Branch to the destination address.
	@Rp	9C	2	8		
	label(B)	AC	3	11		
	off8(Rp)	F4 EC	4	16		
BTJO (1)	A,Pd,off8	86	3	10	0 x x 0	If (s) AND (d) ≠ 0, then PCN + offset → (PC). If the AND of the source and destination operands ≠ 0 (corresponding 1 bits) the PC will add the offset, and the jump will be taken.
	B,A,off8	66	2	10		
	B,Pd,off8	96	3	10		
	Rs,A,off8	16	3	9		
	Rs,B,off8	36	3	9		
	Rs,Rd,off8	46	4	11		
	#iop8,A,off8	26	3	8		
	#iop8,B,off8	56	3	8		
	#iop8,Rd,off8	76	4	10		
	#iop8,Pd,off8	A6	4	11		

**Note 1:** Add two to the cycle count if a jump is taken.

**Legend:**

- 0 Status Bit always cleared.
- 1 Status Bit always set.
- x Status Bit cleared or set on results.
- Status Bit not affected.

Table 13-3. TMS370 Family Instruction Overview (Continued)

Mnemonic		Opcode	Bytes	Cycles $t_c$	Status CNZV	Operation Description
BTJZ (1)	A,Pd,off8	87	3	10	0 x x 0	If (s) AND (not d) $\neq$ 0 then (PCN) + offset $\rightarrow$ (PC) If any 1 in the source corresponds to a 0 in the destination, the PC adds the offset and the jump is taken.
	B,A,off8	67	2	10		
	B,Pd,off8	97	3	10		
	Rs,A,off8	17	3	9		
	Rs,B,off8	37	3	9		
	Rs,Rd,off8	47	4	11		
	#iop8,A,off8	27	3	8		
	#iop8,B,off8	57	3	8		
	#iop8,Rd,off8	77	4	10		
	#iop8,Pd,off8	A7	4	11		
CALL	label	8E	3	13	- - - -	Push PC MSB, PC LSB, XADDR $\rightarrow$ (PC)
	@Rp	9E	2	12		
	label(B)	AE	3	15		
	off8(Rp)	F4 EE	4	20		
CALLR	label	8F	3	15	- - - -	Call Relative Push PC MSB, PC LSB, PCN + (XADDR) $\rightarrow$ (PC)
	@Rp	9F	2	14		
	label(B)	AF	3	17		
	off8(Rp)	F4 EF	4	22		
CLR	A	B5	1	8	0 0 1 0	0 $\rightarrow$ (d) Clear the destination operand.
	B	C5	1	8		
	Rd	D5	2	6		
CLRC		B0	1	9	0 x x 0	0 $\rightarrow$ (C) Clears the carry bit. N and Z bit set on the result of A.
CMP	label,A	8D	3	11	x x x x	Compare; (d) - (s) computed. Set flags on the result of the source operand subtracted from the desti- nation operand. Operands are not affected by operation.
	@Rp,A	9D	2	10		
	label(B),A	AD	3	13		
	off8(Rp),A	F4 ED	4	18		
	off8(SP),A	F3	2	8		
	B,A	6D	1	8		
	Rs,A	1D	2	7		
	Rs,B	3D	2	7		
	Rs,Rd	4D	3	9		
	#iop8,A	2D	2	6		
	#iop8,B	5D	2	6		
	#iop8,Rd	7D	3	8		
CMPBIT	Rname	75	3	8	0 x x 0	Complement Bit; invert the bit
	Pname	A5	3	10		
COMPL	A	BB	1	8	x x x 0	Two's complement; 00h - (s) $\rightarrow$ (d)
	B	CB	1	8		
	Rd	DB	2	6		

**Note 1:** Add two to the cycle count if a jump is taken.

**Legend:**

- 0 Status Bit always cleared.
- 1 Status Bit always set.
- x Status Bit cleared or set on results.
- Status Bit not affected.

**Table 13–3. TMS370 Family Instruction Overview (Continued)**

Mnemonic	Opcode	Bytes	Cycles t <sub>c</sub>	Status C N Z V	Operation Description	
DAC	B,A Rs,A Rs,B Rs,Rd #iop8,A #iop8,B #iop8,Rd	6E 1E 3E 4E 2E 5E 7E	1 2 2 3 2 2 3	10 9 9 11 8 8 10	x x x x	(s) + (d) + (C) → (d) (BCD) The source, destination, and the carry bit are added, and the BCD sum is stored at the destination address.
DEC	A B Rd	B2 C2 D2	1 1 2	8 8 6	x x x x	(d) – 1 → (d) Decrement destination operand by 1.
DINT		F0 00	2	6	0 0 0 0	0 → (ST)(global interrupt enable bits) 0 → IE1, 0 → IE2.
DIV	Rs,A	F4 F8	3	55–63  14	0 x x 0  1 1 1 1	A:B/Rs → A(= quo),B(= REM) Integer divide, 16 by 8 bit. Overflow detected.
DJNZ (1)	A,off8 B,off8 Rd,off8	BA CA DA	2 2 3	10 10 8	– – – –	(d) – 1 → (d); If (d) ≠ 0, then PCN + offset → (PC) Decrement and jump if not 0.
DSB	B,A Rs,A Rs,B Rs,Rd #iop8,A #iop8,B #iop8,Rd	6F 1F 3F 4F 2F 5F 7F	1 2 2 3 2 2 3	10 9 9 11 8 8 10	x x x x	(d) – (s) – 1 + (C) → (d) (BCD) The source operand is subtracted from the destination; this sum is then reduced by 1 and the carry bit is then added to it. The result is stored as a BCD number.
EINT		F0 0C	2	6	0 0 0 0	0Ch → (ST)(global interrupt enable bit) 1 → IE1, 1 → IE2.
EINTH		F0 04	2	6	0 0 0 0	04h → (ST)(high priority global interrupt enable bit). 1 → IE1, 0 → IE2
EINTL		F0 08	2	6	0 0 0 0	08h → (ST)(low priority global interrupt enable bit) 0 → IE1, 1 → IE2

**Note 1:** Add two to the cycle count if a jump is taken.

**Legend:**

- 0 Status Bit always cleared.
- 1 Status Bit always set.
- x Status Bit cleared or set on results.
- Status Bit not affected.

Table 13–3. TMS370 Family Instruction Overview (Continued)

Mnemonic	Opcode	Bytes	Cycles $t_c$	Status C N Z V	Operation Description	
IDLE	F6	1	6	– – – –	(PC) → (PC) until interrupt (PC) + 1 → (PC) after return from interrupt. Stops $\mu$ C execution until an interrupt. Entry to low power modes.	
INC	A B Rd	B3 C3 D3	1 1 2	8 8 6	x x x x x x x x x x x x	(d) + 1 → (d) Increase the destination operand by 1.
INCW	#off8,Rp	70	3	11	x x x x	(Rp) + offset → (Rp) Add 8-bit signed offset to register pair.
INV	A B Rd	B4 C4 D4	1 1 2	8 8 6	0 x x 0 0 x x 0 0 x x 0	NOT(d) → (d) 1's complement the destination operand.
JBIT0 (1)	Rd,off8 Pd,off8	77 A7	4 4	10 11	0 x x 0 0 x x 0	Jump If Bit = 0
JBIT1 (1)	Rd,off8 Pd,off8	76 A6	4 4	10 11	0 x x 0 0 x x 0	Jump If Bit = 1
JMP	off8	00	2	7	– – – –	PCN + off8 → (PC) Jump unconditionally using an 8-bit offset.
JMPL	label @Rp label(B) off8(Rp)	89 99 A9 F4 E9	3 2 3 4	9 8 11 16	– – – – – – – – – – – – – – – –	PCN + D → (PC) Jump unconditionally using a 16-bit offset

**Note 1:** Add two to the cycle count if a jump is taken.

Legend:

- 0 Status Bit always cleared.
- 1 Status Bit always set.
- x Status Bit cleared or set on results.
- Status Bit not affected.



Table 13–3. TMS370 Family Instruction Overview (Continued)

Mnemonic	Opcode	Bytes	Cycles $t_e$	Status C N Z V	Operation Description	
Jcnd (1)	JC JEQ JG JGE JHS JL JLE JLO JN JNC JNE JNV JNZ JP JPZ JV JZ	03 02 0E 0D 0B 09 0A 0F 01 07 06 0C 06 04 05 08 02	2 2 2 2 2 2 2 2 2 2 2 2 2 2 2 2 2	5 5 5 5 5 5 5 5 5 5 5 5 5 5 5 5 5	– – – –	Conditional jump Carry Jump Equal Greater Than, signed Greater Than or Equal, signed Higher or Same, unsigned Less Than, signed Less Than or Equal, signed Lower Value, unsigned Negative, signed No Carry Jump Not Equal No Overflow, signed Not Zero Positive, signed Positive or Zero, signed Overflow, signed Zero
LDSP	FD	1	7	– – – –	(B) → (SP) Load stack pointer with contents of register B.	
LDST #iop8	F0	2	6	x x x x	(s) → (ST) Load ST Register	

**Note 1:** Add two to the cycle count if a jump is taken.

**Legend:**

- 0 Status Bit always cleared.
- 1 Status Bit always set.
- x Status Bit cleared or set on results.
- Status Bit not affected.

Table 13–3. TMS370 Family Instruction Overview (Continued)

Mnemonic	Opcode	Bytes	Cycles $t_c$	Status C N Z V	Operation Description	
MOV	A,B A,Rd A,Pd A,label A,@Rp A,label(B) A,off8(Rp) A,off8(SP) Rs,A Rs,B label,A @Rp,A label(B),A off8(Rp),A off8(SP),A B,A B,Rd B,Pd Rs,Rd Rs,Pd Ps,A Ps,B Ps,Rd #iop8,A #iop8,B #iop8,Rd #iop8,Pd	C0 D0 21 8B 9B AB F4 EB F2 12 32 8A 9A AA F4 EA F1 62 D1 51 42 71 80 91 A2 22 52 72 F7	1 2 2 3 2 3 4 2 2 2 3 2 3 4 2 2 3 2 2 3 2 2 2 3 2 3 3	9 7 8 10 9 12 17 7 7 7 10 9 12 17 7 8 7 8 9 10 8 8 10 6 6 8 10	0 x x 0	(s) → (d) Replace the destination operand with the source operand.
MOVW	Rps,Rpd #iop16,Rpd #iop16(B),Rpd off8(Rs),Rpd	98 88 A8 F4 E8	3 4 4 5	12 13 15 20	0 x x 0	(s) → (Rd–1:Rd) Copy the source register word to the destination register pair.
MPY	B,A Rs,A Rs,B Rs,Rd #iop8,A #iop8,B #iop8,Rn	6C 1C 3C 4C 2C 5C 7C	1 2 2 3 2 2 3	47 46 46 48 45 45 47	0 x x 0	(s) × (d) → (A:B) Multiply the source and destination operands, store the result in Registers A (MSB) and B (LSB).
NOP		FF	1	7	– – – –	No operation

**Note 1:** Add two to the cycle count if a jump is taken.

**Legend:**

- 0 Status Bit always cleared.
- 1 Status Bit always set.
- x Status Bit cleared or set on results.
- Status Bit not affected.

**Table 13–3. TMS370 Family Instruction Overview (Continued)**

Mnemonic	Opcode	Bytes	Cycles $t_c$	Status C N Z V	Operation Description	
OR	A,Pd B,A B,Pd Rs,A Rs,B Rs,Rd #iop8,A #iop8,B #iop8,Rd #iop8,Pd	84 64 94 14 34 44 24 54 74 A4	2 1 2 2 2 3 2 2 3 3	9 8 9 7 7 9 6 6 8 10	0 x x 0	(s) OR (d) → (d)  Logically OR the source and destination operands, and store the results at the destination address.
POP	A B Rd ST	B9 C9 D9 FC	1 1 2 1	9 9 7 8	0 x x 0   x x x x	((SP) → (d) (SP) –1 → (SP)
PUSH	A B Rd ST	B8 C8 D8 FB	1 1 2 1	9 9 7 8	0 x x 0   - - - -	(SP) + 1 → (SP) (s) → ((SP)) Copy the operand onto the stack. Copy the status register onto the stack
RL	A B Rd	BE CE DE	1 1 2	8 8 6	x x x 0	Bit(n) → Bit(n + 1) Bit(7) → Bit(0) and Carry
RLC	A B Rd	BF CF DF	1 1 2	8 8 6	x x x 0	Bit(n) → Bit(n + 1) Carry → Bit(0) Bit(7) → Carry
RR	A B Rd	BC CC DC	1 1 2	8 8 6	x x x 0	Bit(n + 1) → Bit(n) Bit(0) → Bit(7) and Carry
RRC	A B Rd	BD CD DD	1 1 2	8 8 6	x x x 0	Bit(n + 1) → Bit(n) Carry → Bit(7) Bit(0) → Carry
RTI		FA	1	12	x x x x	Pop PCL, PCH, POP ST Return From Interrupt
RTS		F9	1	9	- - - -	Pop PCL, PCH
SBB	B,A Rs,A Rs,B Rs,Rd #iop8,A #iop8,B #iop8,Rd	6B 1B 3B 4B 2B 5B 7B	1 2 2 3 2 2 3	8 7 7 9 6 6 8	x x x x	(d) – (s) – 1 + (C) → (d) Subtract with borrow. Destination minus source minus 1 plus carry; stored at the destination address.

**Note 1:** Add two to the cycle count if a jump is taken.

**Legend:**

- 0 Status Bit always cleared.
- 1 Status Bit always set.
- x Status Bit cleared or set on results.
- Status Bit not affected.

Table 13–3. TMS370 Family Instruction Overview (Concluded)

Mnemonic	Opcode	Bytes	Cycles $t_c$	Status C N Z V	Operation Description	
SBIT0	Rd	73	3	8	0 x x 0	Set Bit to 0
	Pd	A3	3	10		
SBIT1	Rd	74	3	8	0 x x 0	Set Bit to 1
	Pd	A4	3	10		
SETC		F8	1	7	1 0 1 0	Axh $\rightarrow$ (ST) Set the carry bit. IE1 and IE2 unchanged.
STSP		FE	1	8	– – – –	(SP) $\rightarrow$ (B) Copy the SP into Register B.
SUB	B,A	6A	1	8	x x x x	(d) – (s) $\rightarrow$ (d) Store the destination operand minus the source operand into the destina- tion.
	Rs,A	1A	2	7		
	Rs,B	3A	2	7		
	Rs,Rd	4A	3	9		
	#iop8,A	2A	2	6		
	#iop8,B	5A	2	6		
#iop8,Rd	7A	3	8			
SWAP	A	B7	1	11	0 x x 0	s(7-4,3-0) $\rightarrow$ d(3-0,7-4) Swap the operand's hi and lo nibbles.
	B	C7	1	11		
	Rd	D7	2	9		
TRAP	n	EF–E0	1	14	– – – –	Vector n $\rightarrow$ (PC), n = 0 $\rightarrow$ 15 Trap to Subroutine; Push PCN Trap 0 = EF
TST	A	B0	1	9	0 x x 0	Test; Set flags from register.
	B	C6	1	10		
XCHB	A	B6	1	10	0 x x 0	(B) $\leftrightarrow$ (Rn) Swap the contents of Register B with (Rn).
	B	C6	1	10		
	Rd	D6	2	8		
XOR	A,Pd	85	2	9	0 x x 0	(s) XOR (d) $\rightarrow$ (d) Logically exclusive OR the source and destination operands, store at the destination address.
	B,A	65	1	8		
	B,Pd	95	2	9		
	Rs,A	15	2	7		
	Rs,B	35	2	7		
	Rs,Rd	45	3	9		
	#iop8,A	25	2	6		
	#iop8,B	55	2	6		
	#iop8,Rd	75	3	8		
	#iop8,Pd	A5	3	10		

**Note 1:** Add two to the cycle count if a jump is taken.

**Legend:**

- 0 Status Bit always cleared.
- 1 Status Bit always set.
- x Status Bit cleared or set on results.
- Status Bit not affected.

Table 13–4 provides an opcode-to-instruction cross reference of all 73 instructions and 246 opcodes of the TMS370 instruction set. To check the instruction of a known opcode, locate the left (high) digit across the top or bottom of the table, then find the right (low) digit along the side of the table. The intersection contains the instruction mnemonic, operands, and byte/cycle particular to that opcode. Some opcodes, such as B0, are shared by two instructions, in which case both mnemonics are shown along with the byte/cycles count.

Table 13-4. TMS370 Family Opcode/Instruction Map

		MSN															
		0	1	2	3	4	5	6	7	8	9	A	B	C	D	E	F
0	JMP ra 2/7								INCW #n,Rd 3/11	MOV Ps,A 2/8					MOV A,Rd 2/7	TRAP 15 1/14	LDST n 2/6
1	JN ra 2/5			MOV A,Pd 2/8					MOV Rs,Pd 3/10		MOV Ps,B 2/7				MOV B,Rd 2/7	TRAP 14 1/14	MOV n(SP),A 2/7
2	JZ ra 2/5	MOV Rs,A 2/7	MOV Rs,B 2/7	MOV Rs,Rd 3/9	MOV Rs,Rd 3/9	MOV B,A 1/8	MOV #n,B 2/6	MOV #n,Rd 3/8	MOV #n,Rd 3/8			MOV Ps,Rd 3/10	DEC A 1/8	DEC B 1/8	DEC Rn 2/6	TRAP 13 1/14	MOV A,n(SP) 2/7
3	JC ra 2/5	Rs,A 2/7	Rs,B 2/7	AND Rs,Rd 3/9	AND Rs,Rd 3/9	AND B,A 1/8	AND #n,B 2/6	AND #n,Rd 3/8	AND A,Pd 2/9	AND B,Pd 2/9	AND #n,Pd 3/10	AND #n,Pd 3/10	INC A 1/8	INC B 1/8	INC Rn 2/6	TRAP 12 1/14	CMP n(SP),A 2/6
4	JP ra 2/5	Rs,A 2/7	Rs,B 2/7	OR Rs,Rd 3/9	OR Rs,Rd 3/9	OR B,A 1/8	OR #n,B 2/6	OR #n,Rd 3/8	OR A,Pd 2/9	OR B,Pd 2/9	OR #n,Pd 3/10	OR #n,Pd 3/10	INV A 1/8	INV B 1/8	INV Rn 2/6	TRAP 11 1/14	extend inst:2 opcode:s
5	JPZ ra 2/5	XOR Rs,A 2/7	XOR Rs,B 2/7	XOR Rs,Rd 3/9	XOR Rs,Rd 3/9	XOR B,A 1/8	XOR #n,B 2/6	XOR #n,Rd 3/8	XOR A,Pd 2/9	XOR B,Pd 2/9	XOR #n,Pd 3/10	XOR #n,Pd 3/10	CLR A 1/8	CLR B 1/8	CLR Rn 2/6	TRAP 10 1/14	
6	JNZ ra 2/5	BTJO Rs,A 3/9	BTJO Rs,B 3/9	BTJO Rs,Rd 4/11	BTJO Rs,Rd 4/11	BTJO B,A 2/10	BTJO #n,B 3/8	BTJO #n,Rd 4/10	BTJO A,Pd 3/11	BTJO B,Pd 3/10	BTJO #n,Pd 4/11	BTJO #n,Pd 4/11	XCHB A 1/10	XCHB A / TST B 1/10	XCHB Rn 2/8	TRAP 9 1/14	IDLE 1/6
7	JNC ra 2/5	BTJZ Rs,A 3/9	BTJZ Rs,B 3/9	BTJZ Rs,Rd 4/11	BTJZ Rs,Rd 4/11	BTJZ B,A 2/10	BTJZ #n,B 3/8	BTJZ #n,Rd 4/10	BTJZ A,Pd 3/10	BTJZ B,Pd 3/10	BTJZ #n,Pd 4/11	BTJZ #n,Pd 4/11	SWAP A 1/11	SWAP B 1/11	SWAP Rn 2/9	TRAP 8 1/14	MOV #n,Pd 3/10
8	JV ra 2/5	ADD Rs,A 2/7	ADD Rs,B 2/7	ADD Rs,Rd 3/9	ADD Rs,Rd 3/9	ADD B,A 1/8	ADD #n,B 2/6	ADD #n,Rd 3/8	MOVW #16,Rd 4/13	MOVW Rs,Rd 3/12	MOVW #16(B),Rd 4/15	MOVW #16(B),Rd 4/15	PUSH A 1/9	PUSH B 1/9	PUSH Rs 2/7	TRAP 7 1/14	SETC 1/7
9	JL ra 2/5	ADC Rs,A 2/7	ADC Rs,B 2/7	ADC Rs,Rd 3/9	ADC Rs,Rd 3/9	ADC B,A 1/8	ADC #n,B 2/6	ADC #n,Rd 3/8	JMPL lab 3/9	JMPL @Rd 2/8	JMPL lab(B) 3/11	JMPL lab(B) 3/11	POP A 1/9	POP B 1/9	POP Rd 2/7	TRAP 6 1/14	RTS 1/9
A	JLE ra 2/5	SUB Rs,A 2/7	SUB Rs,B 2/7	SUB Rs,Rd 3/9	SUB Rs,Rd 3/9	SUB B,A 1/8	SUB #n,B 2/6	SUB #n,Rd 3/8	MOV lab,A 2/9	MOV @Rs,A 2/9	MOV lab(B),A 3/12	MOV lab(B),A 3/12	DJNZ A,Ra 2/10	DJNZ B,Ra 2/10	DJNZ Rn,Ra 3/8	TRAP 5 1/14	RTI 1/12
B	JHS ra 2/5	SBB Rs,A 2/7	SBB Rs,B 2/7	SBB Rs,Rd 3/9	SBB Rs,Rd 3/9	SBB B,A 1/8	SBB #n,B 2/6	SBB #n,Rd 3/8	MOV A,@Rd 2/9	MOV @Rs,A 2/9	MOV A,@Rd 3/12	MOV A,lab(B) 3/12	COMPL A 1/8	COMPL B 1/8	COMPL Rn 2/6	TRAP 4 1/14	PUSH ST 1/8

L S N

Table 13-4. TMS370 Family Opcode/Instruction Map (Concluded)

	MSN																
	0	1	2	3	4	5	6	7	8	9	A	B	C	D	E	F	
C	JNV ra 2/5	MPY Rs,A 2/46	MPY #n,A 2/45	MPY Rs,B 2/46	MPY Rs,Rd 3/48	MPY #n,B 2/45	MPY B,A 1/47	MPY #n,Rs 3/47	BR lab 3/9	BR @Rd 2/8	BR lab(B) 3/11	RR A 1/8	RR B 1/8	RR Rn 2/6	TRAP 3 1/14	POP ST 1/8	
D	JGE ra 2/5	CMP Rs,A 2/7	CMP #n,A 2/6	CMP Rs,B 2/7	CMP Rs,Rd 3/9	CMP #n,B 2/6	CMP B,A 1/8	CMP #n,Rd 3/8	CMP lab,A 3/11	CMP @Rs,A 2/10	CMP lab(B),A 3/13	RRC A 1/8	RRC B 1/8	RRC Rn 2/6	TRAP 2 1/14	LDSP 1/7	
E	JG ra 2/5	DAC Rs,A 2/9	DAC #n,A 2/8	DAC Rs,B 2/9	DAC Rs,Rd 3/11	DAC #n,B 2/8	DAC B,A 1/10	DAC #n,Rd 3/10	CALL lab 3/13	CALL @Rd 2/12	CALL lab(B) 3/15	RL A 1/8	RL B 1/8	RL Rn 2/6	TRAP 1 1/14	STSP 1/8	
F	JLO ra 2/5	DSB Rs,A 2/9	DSB #n,A 2/8	DSB Rs,B 2/9	DSB Rs,Rd 3/11	DSB #n,B 2/8	DSB B,A 1/10	DSB #n,Rd 3/10	CALLR lab 3/15	CALLR @Rd 2/14	CALLR lab(B) 3/17	RLC A 1/8	RLC B 1/8	RLC Rn 2/6	TRAP 0 1/14	NOP 1/7	

Instruction	Second byte of two-byte instructions (F4xx):	F4	F4	F4	F4	F4	F4	F4	F4	F4
MOVW n(Rn) 4/15	8									
JMPL n(Rn) 4/16	9									
MOV n(Rn),A 4/17	A									
MOV A,n(Rn) 4/16	B									
BR n(Rn) 4/16	C									
CMP n(Rn),A 4/18	D									
CALL n(Rn) 4/20	E									
CALLR n(Rn) 4/22	F									

rs - relative address  
Rn - Register  
Rs - Register containing source byte  
Rd - Register containing destination byte  
Ps - Peripheral register containing source byte  
Pd - Peripheral register containing destination byte  
Pn - Peripheral register  
n - Immediate 8-bit number  
lab - 16-bit label

**Note:** All conditional jumps (opcodes 01-0F), BTJO, BTJZ, and DJNZ instructions use two additional cycles if the branch is taken. The BTJO, BTJZ, and DJNZ instructions have a relative address as the last operand.

## 13.4 Instruction Set Descriptions

The TMS370 instruction set contains 73 instructions using 246 unique opcodes. Each operation has an associated opcode. Some instructions, including those using the offset indirect addressing mode, have 16-bit (or dual) opcodes. In two cases, an opcode is shared by two instructions. This is to aid the programmer in understanding the operation associated with the opcode, as well as to enhance the readability of the source code. The following pages contain the individual instruction descriptions. The instructions are in alphabetical order by mnemonic.



**Syntax**      **ADC** *s, Rd*

**Execution**     $(s) + (Rd) + (C) \rightarrow (Rd)$

<b>Options</b>	<u>inst</u>	<u>operands</u>	<u>bytes</u>	<u>cycles</u>	<u>opcode</u>	<u>operation</u>
	ADC	B,A	1	8	69	$(B)+(A)+(C) \rightarrow (A)$
	ADC	Rs,A	2	7	19	$(Rs)+(A)+(C) \rightarrow (A)$
	ADC	Rs,B	2	7	39	$(Rs)+(B)+(C) \rightarrow (B)$
	ADC	Rs,Rd	3	9	49	$(Rs)+(Rd)+(C) \rightarrow (Rd)$
	ADC	#iop8,A	2	6	29	$iop8+(A)+(C) \rightarrow (A)$
	ADC	#iop8,B	2	6	59	$iop8+(B)+(C) \rightarrow (B)$
	ADC	#iop8,Rd	3	8	79	$iop8+(Rd)+(C) \rightarrow (Rd)$

### Status Bits

<b>Affected</b>	<b>C</b>	Set to 1 on carry-out of $(s) + (Rd) + (C)$
	<b>Z</b>	Set on result
	<b>N</b>	Set on result
	<b>V</b>	$(C \text{ XOR } N) \text{ AND } (\text{source} [\text{bit } 7] \text{ XOR } \text{destination} [\text{bit } 7])$

**Description**    ADC adds the contents of the source, the destination register, and the carry bit. It stores the result in the destination register.

Adding a 0 to the destination register is equivalent to a conditional increment (increment on carry).

ADC can implement multi-precision addition of signed or unsigned integers. For example, the 16-bit integer in register pair (R2,R3) may be added to the 16-bit integer in (A,B) as follows:

```

ADD R3,B           ;Low order bytes added
ADC R2,A           ;High order bytes added

```

**Examples**

```

LABEL1  ADC R66,R117      ;Adds the contents of
                          ;register 66, register
                          ;117, and the carry bit,
                          ;and stores the sum in
                          ;register 117

                          ADC B,A          ;Adds the contents of
                          ;Register B, Register A,
                          ;and the carry bit, and
                          ;stores the sum in
                          ;Register A

                          ADC #03Ch,R29   ;Adds #3Ch, contents of
                          ;register 29, and the
                          ;carry bit, and stores
                          ;the sum in register 29

```



**Syntax** AND *s*, *Rd*

**Execution** (*s*) AND (*Rd*) → (*Rd*)

<b>Options</b>	<u>inst</u>	<u>operands</u>	<u>bytes</u>	<u>cycles</u>	<u>opcode</u>	<u>operation</u>
AND A,Pd			2	9	83	(A) AND (Pd) → (Pd)
AND B,A			1	8	63	(B) AND (A) → (A)
AND B,Pd			2	9	93	(B) AND (Pd) → (Pd)
AND Rs,A			2	7	13	(Rs) AND (A) → (A)
AND Rs,B			2	7	33	(Rs) AND (B) → (B)
AND Rs,Rd			3	9	43	(Rs) AND (Rd) → (Rd)
AND #iop8,A			2	6	23	iop8 AND (A) → (A)
AND #iop8,B			2	6	53	iop8 AND (B) → (B)
AND #iop8,Rd			3	8	73	iop8 AND (Rd) → (Rd)
AND #iop8,Pd			3	10	A3	iop8 AND (Pd) → (Pd)

**Status Bits**

**Affected**

- C** ← 0
- N** Set on result
- Z** Set on result
- V** ← 0

**Description** AND logically ANDs the two 8-bit operands. Each bit in the first operand is ANDed with the corresponding bit in the second operand. This is useful for clearing bits. If you need to clear a bit in the destination operand, then put a 0 in the corresponding source bit. A 1 in a source bit will not change the corresponding destination bit.

**Examples**

```

LABEL    AND #01h,R12    ;Clear all bits in R12 except
                                ;Bit 0, which will remain
                                ;unchanged

                                AND R7,A    ;AND the contents of R7 to A
                                ;and store the contents in A

                                AND B,P025   ;AND contents of B to P025,
                                ;store the contents in P025
    
```

**Syntax** BR XADDR

**Execution** XADDR → (PC)

<b>Options</b>	<u>inst</u>	<u>operands</u>	<u>bytes</u>	<u>cycles</u>	<u>opcode</u>	<u>operation</u>
	BR	label	3	9	8C	label → (PC)
	BR	label(B)	3	11	AC	label+(B) → (PC)
	BR	off8(Rp)	4	16	F4 EC	(Rn-1:Rn)+off8 → (PC)
	BR	@Rp	2	8	9C	(Rn-1:Rn) → (PC)

**Note:** label = unsigned 16-bit value  
 (B) = unsigned 8-bit value  
 off8 = signed 8-bit value

**Status Bits**

**Affected** None

**Description** BR branches to **any** location in memory, including the on-chip RAM. BR supports the four extended absolute addressing modes:

- Direct
- Indirect
- Indexed
- Offset Indirect

The powerful concept of computed GOTOs is supported by the BR @Rn instruction. An indexed branch instruction of the form BR TABLE(B) is an extremely efficient way to execute one of several actions on the basis of a control input. This is similar to the Pascal CASE statement. The program can branch to up to 128 different jump statements. This technique may also be used to transfer control on character inputs, error codes, etc.

**Examples**

```

LABEL    BR    LABEL4           ; (PC) ← LABEL4

          BR    5432h           ; (PC) ← 5432h

          BR    LABEL5 (B)      ; (PC) ← LABEL5 + (B)

          BR    1234h (B)       ; (PC) ← 1234h + (B)

          BR    @R12            ; (PC) ← (R11:R12) R12 = LSB

          BR    56 (R10)        ; (PC) ← 56 + (R9:R10) R10 = LSB
  
```

**Syntax** BTJO *s,d,off8*

**Execution** If (s) AND (d) ≠ 0, then PCN + off8 → (PC), else PCN → (PC)

<b>Options</b>	<u>inst</u>	<u>operands</u>	<u>bytes</u>	<u>cycles</u>	<u>opcode</u>	<u>Jump If</u>
	BTJO	A,Pd,label	3	10/12	86	(A) AND (Pd) ≠ 0
	BTJO	B,A,label	2	10/12	66	(B) AND (A) ≠ 0
	BTJO	B,Pd,label	3	10/12	96	(B) AND (Pd) ≠ 0
	BTJO	Rs,A,label	3	9/11	16	(Rd) AND (A) ≠ 0
	BTJO	Rs,B,label	3	9/11	36	(Rd) AND (B) ≠ 0
	BTJO	Rs,Rd,label	4	11/13	46	(Rd) AND (Rs)≠ 0
	BTJO	#iop8,A,label	3	8/10	26	(A) AND off8 ≠ 0
	BTJO	#iop8,B,label	3	8/10	56	(B) AND off8 ≠ 0
	BTJO	#iop8,Rd,label	4	10/12	76	(Rd) AND off8 ≠ 0
	BTJO	#iop8,Pd,label	4	11/13	A6	(Pd) AND off8 ≠ 0

### Status Bits

<b>Affected</b>	<b>C</b>	← 0
	<b>N</b>	Set on (s) AND (d)
	<b>Z</b>	Set on (s) AND (d)
	<b>V</b>	← 0

**Description** BTJO jumps if at least one corresponding bit position in the source and destination are both 1. The source operand can be used as a bit mask to test for one or more 1 bits in the specified register. The operands are not changed by this instruction. If one or more corresponding 1 bits are found, the program branches to the offset (refer to the table below).

(s)	(d)	Jump?
00000001	xxxxxxx0	No
00000001	xxxxxxx1	Yes
00000011	xxxxxx00	No
11110000	1000xxxx	Yes
11110000	1001xxxx	Yes

**BTJO** *Bit Test and Jump If One*

---

**Examples**

```
LABEL    BTJO #014,R4,ISSET    ;Jump to ISSET if R4
                                           ;(bit 2) or R4 (bit
                                           ;4) is a 1

                                           BTJO #01,A,LOOP            ;Jump to LOOP if bit 0
                                           ;of Register A is a 1

                                           BTJO R37,R113,START        ;Jump to START if any
                                           ;1 bit of R113 corre
                                           ;sponds to a 1 bit
                                           ;in R37
```

**Syntax**      **BTJZ** *s,d,off8*

**Execution**    If (s) AND NOT (d)  $\neq$  0, then PCN + off8  $\rightarrow$  (PC), else PCN  $\rightarrow$  (PC)

<b>Options</b>	<u>inst</u>	<u>operands</u>	<u>bytes</u>	<u>cycles</u>	<u>opcode</u>	<u>Jump If</u>
	BTJZ	A,Pd,label	3	10/12	87	(A) AND NOT(Pd) $\neq$ 0
	BTJZ	B,A,label	2	10/12	67	(B) AND NOT(A) $\neq$ 0
	BTJZ	B,Pd,label	3	10/12	97	(Pd) AND NOT(B) $\neq$ 0
	BTJZ	Rd,A,label	3	9/11	17	(Rd) AND NOT(A) $\neq$ 0
	BTJZ	Rd,B,label	3	9/11	37	(Rd) AND NOT(B) $\neq$ 0
	BTJZ	Rs,Rd,label	4	11/13	47	(Rs) AND NOT(Rd) $\neq$ 0
	BTJZ	#iop8,A,label	3	8/10	27	off8 AND NOT (A) $\neq$ 0
	BTJZ	#iop8,B,label	3	8/10	57	off8 AND NOT (B) $\neq$ 0
	BTJZ	#iop8,Rd,label	4	10/12	77	off8 AND NOT (Rd) $\neq$ 0
	BTJZ	#iop8,Pd,label	4	11/13	A7	off8 AND NOT (Pd) $\neq$ 0

### Status Bits

**Affected**

**C**       $\leftarrow$  0

**N**      Set on (s) AND NOT (Rd)

**Z**      Set on (s) AND NOT (Rd)

**V**       $\leftarrow$  0

**Description**    BTJZ jumps if at least one corresponding bit position has a 1 in the source and a 0 in the destination (refer to the table below). The source operand can be used as a bit mask to test for zero bits in the specified register. The operands are unchanged by this instruction. The jump is calculated starting from the opcode of the instruction just after the BTJZ.

(s)	(d)	Jump?
00000001	xxxxxxx0	Yes
00000001	xxxxxxx1	No
11000000	11xxxxxx	No
11110000	0111xxxx	Yes
11110000	0110xxxx	Yes

**Examples**

LABEL      BTJZ A,P23,ZERO    ;If any 1 bits in A  
;correspond to 0 bits  
;in P23, 0 then jump to  
;ZERO

BTJZ #0FFh,A,NEXT ;If A contains any 0  
;bits, jump to NEXT

BTJZ R7,R15,OUT    ;If any 0 bits in R15  
;correspond to 1 bits  
;in R7, jump to OUT

**Syntax**      **CALL** *XADDR*

**Execution**    (SP) + 1    → (SP)  
                   PCN MSB    → ((SP))  
                   (SP) + 1    → (SP)  
                   PCN LSB    → ((SP))  
                   XADDR      → (PC)  
 (The stack contains the address of the instruction immediately following the CALL.)

<b>Options</b>	<u>inst</u>	<u>operands</u>	<u>bytes</u>	<u>cycles</u>	<u>opcode</u>	<u>operation</u>
	CALL	label	3	13	8E	label → (PC)
	CALL	label(B)	3	15	AE	label+(B) → (PC)
	CALL	off8(Rd)	4	20	F4 EE	(Rd-1:Rd)+off8 → (PC)
	CALL	@Rd	2	12	9E	(Rd-1:Rd) → (PC)

**Note:** offset = signed 16-bit value  
 (B) = unsigned 8-bit value  
 off8 = signed 8-bit value

**Status Bits**

**Affected**    None

**Description** CALL invokes a subroutine and pushes the PC contents on the stack. The operand indicates the starting address of the subroutine. The extended addressing modes of the CALL instruction allow powerful transfer of control functions.

**Examples**

```

LABEL      CALL LABEL4                    ;Push PC; (PC) ← LABEL4

            CALL 5432h                    ;Push PC; (PC) ← 5432h

            CALL LABEL5(B)                ;Push PC; (PC) ← LABEL5 + (B)

            CALL 1234h(B)                 ;Push PC; (PC) ← 1234h + (B)

            CALL @R12                     ;Push PC; (PC) ← (R11:R12)
                                          ;R12 = LSB

            CALL 56(R10)                  ;Push PC; (PC) ← 56 +
                                          ;(R9:R10)    R10 = LSB
  
```



**Syntax**      **CALLR** *XADDR*

**Execution**    (SP) + 1    → (SP)  
                  PCN MSB    → ((SP))  
                  (SP) + 1    → (SP)  
                  PCN LSB    → ((SP))  
                  XADDR + PCN    → (PC)

<b>Options</b>	<u>inst</u>	<u>operands</u>	<u>bytes</u>	<u>cycles</u>	<u>opcode</u>	<u>operation</u>
	CALLR	label	3	15	8F	off16 + PCN → (PC)
	CALLR	label(B)	3	17	AF	off16 + (B) + PCN → (PC)
	CALLR	off8(Rp)	4	22	F4 EF	(Rd-1:Rd) + off8 + PCN → (PC)
	CALLR	@Rd	2	14	9F	(Rd-1:Rd) + PCN → (PC)

**Note:** off16 = signed 16-bit value  
           (B) = unsigned 8-bit value  
           off8 = signed 8-bit value

**Status Bits  
 Affected**

None

**Description**    CALLR is similar to CALL, but uses a value relative to the current program counter (PCN). The extended relative addressing modes of the CALLR instruction allow powerful transfer of control functions. This is useful for relocatable code produced by linkers, compilers or other high language structures. The assembler automatically calculates the correct offset value for the two modes using labels in the operands.

**Examples**

Direct Addressing

```
LABEL      CALLR LABEL4            ;push PC ; (PC) ← PCN +
                                         ;off16, off16 = LABEL4-PCN
```

```
                 CALLR 5432h        ;push PC ; (PC) ← PCN +
                                         ;5432h
```

Indexed Addressing

```
                 CALLR LABEL5(B)    ;push PC ; (PC) ← PCN +
                                         ;off16 + (B)
                                         ;off16=LABEL5 - PCN
```

```
                 CALLR 1234h(B)     ;push PC ; (PC) ← PCN +
                                         ;1234h + (B)
```

Indirect Addressing

```
                 CALLR @R12         ;push PC ; (PC) ← PCN +
                                         ;(R11:R12)
                                         ;R12=LSB
```

Offset Indirect Addressing

```
                 CALLR 56(R10)      ;push PC ; (PC) ← PCN
                                         ;+ 56 + (R9:R10)
                                         ;R10=LSB
```

**Syntax** CLR *Rn*

**Execution** 0 → (*Rn*)

<b>Options</b>	<u>inst</u>	<u>operands</u>	<u>bytes</u>	<u>cycles</u>	<u>opcode</u>	<u>operation</u>
	CLR	A	1	8	B5	0 → (A)
	CLR	B	1	8	C5	0 → (B)
	CLR	<i>Rn</i>	2	6	D5	0 → ( <i>Rn</i> )

**Status Bits**

**Affected**

<b>C</b>	← 0
<b>N</b>	← 0
<b>Z</b>	← 1
<b>V</b>	← 0

**Description** CLR clears or initializes to 0 any register including Registers A and B.

**Examples**

```

LABEL      CLR B           ;Clear Register B

           CLR A           ;Clear Register A

           CLR R105        ;Clear register 105

```

**Syntax** CLRC

**Execution** Set status bits

<b>Options</b>	<u>inst</u>	<u>operands</u>	<u>bytes</u>	<u>cycles</u>	<u>opcode</u>
CLRC		none	1	9	B0

**Status Bits**

**Affected**

<b>C</b>	← 0
<b>N</b>	Set on value of Register A
<b>Z</b>	Set on value of Register A
<b>V</b>	← 0

**Description** CLRC clears the carry flag. This may be required before an arithmetic or rotate instruction. The logical and move instructions typically clear the carry bit. The CLRC opcode is equivalent to the TST A opcode.

**Example** LABEL CLRC ;Clear the carry bit

**Syntax**      **CMP** *s,d***Execution**    (d) – (s) computed but not stored

<b>Options</b>	<u>inst</u>	<u>operands</u>	<u>bytes</u>	<u>cycles</u>	<u>opcode</u>	<u>operation</u>
General:						
	CMP	B,A	1	8	6D	(A)-(B)
	CMP	Rs,A	2	7	1D	(A)-(Rs)
	CMP	Rs,B	2	7	3D	(B)-(Rs)
	CMP	Rs,Rd	3	9	4D	(Rd)-(Rs)
	CMP	#iop8,A	2	6	2D	(A)-iop8
	CMP	#iop8,B	2	6	5D	(B)-iop8
	CMP	#iop8,Rd	3	8	7D	(Rd)-iop8

Extended:

	CMP	label,A	3	11	8D	(A)-(label)
	CMP	label(B),A	3	13	AD	(A)-(label+(B))
	CMP	off8(Rp),A	4	18	F4 ED	(A)-((Rn-1:Rn)+off8)
	CMP	@Rp,A	2	10	9D	(A)-((Rn-1:Rn))
	CMP	off8(SP),A	2	8	F3	(A)-((SP)+off8)

**Note:** Operations are computed but not stored.  
Status bits are set on results.

**Status Bits**

<b>Affected</b>	<b>C</b>	1 if (d) ≥ (s)
	<b>N</b>	Sign of result
	<b>Z</b>	1 if (d) = (s)
	<b>V</b>	(C XOR N) AND (Source [bit 7] XOR Destination [bit 7])

**Description** CMP compares the destination operand to the source operand and sets the status bits. The CMP instruction is usually used in conjunction with a Jump instruction. Table 13–5 shows which Jump instructions can be used on status conditions set by CMP execution. There are only seven possible outcomes of the status register after a compare instruction. The jump instructions JC and JHS are equivalent after a compare.

**Table 13-5. Compare Instruction Examples – Status Bit Values**

Operand Opcodes (S) (D)	Status Bits CNZV	JGE	JG	JL	JLE	JLO	JHS	JC	JNC	JN	JP	JEQ/JZ	JPZ	JNE/JNZ	JV	JNV
FF 00 81 00	0000	1	1	0	0	1	0	0	1	0	1	0	1	1	0	1
80 00 80 7F	0101	1	1	0	0	1	0	0	1	1	0	0	0	1	1	0
00 7F 20 30 90 A0	1000	1	1	0	0	0	1	1	0	0	1	0	1	1	0	1
7F 00 30 20 A0 90	0100	0	0	1	1	1	0	0	1	1	0	0	0	1	0	1
7F 80	1001	0	0	1	1	0	1	1	0	0	1	0	1	1	1	0
00 FF 00 81 00 80	1100	0	0	1	1	0	1	1	0	1	0	0	0	1	0	1
7F 7F	1010	1	0	0	1	0	1	1	0	0	0	1	1	0	0	1

**Notes:** 1) Signed Jumps: JGE, JG, JL, JLE.  
 Unsigned Jumps: JLO, JHS.  
 Test Bits: JC, JNC, JN, JP, JEQ/JZ, JPZ, JNE/JNZ, JV, JNZ

2) 1 = jump was taken; 0 = does not jump

**Examples**

```

LABEL      CMP R13,R89      ;Set status bits on
                                ;result of R89 minus R13

                                CMP R39,B      ;Set status bits on result
                                ;of (B) minus R39

                                CMP #003,A      ;Set status bits on result
                                ;of (A) minus #03h

                                CMP TABLE(B),A ;Set status bits on result
                                ;of (A) minus (TABLE + (B))

```

**CMPBIT** *Complement Bit***Syntax**      **CMPBIT** *name***Execution**    NOT <name> → <name>

<b>Options</b>	<u>inst</u>	<u>operands</u>	<u>bytes</u>	<u>cycles</u>	<u>opcode</u>	<u>operation</u>
	CMPBIT	Rname	3	8	75	NOT (bit) → (bit) Reg. bits
	CMPBIT	Pname	3	10	A5	NOT (bit) → (bit) Per. bits

**Status Bits**

**Affected**

**C**      ← 0

**N**      Set on result of (Mask XOR (s))

**Z**      Set on result of (Mask XOR (s))

**V**      ← 0

**Description**    CMPBIT is an assembler constructed instruction that conveniently complements the value of the named bit without having to specify a register or mask. This enhances the readability of the software. The CMPBIT instruction assembles to the instructions XOR #iop8,Rd or XOR #iop8,Pd. The name for the bit is defined by the .DBIT assembler directive.

**Examples**

```
INT1ENA    .DBIT 7,P017            ;Interrupt 1 bit is now
                                 ;named INT1ENA

TEST        .DBIT 4,R33           ;Bit 4 of register 33 is now
                                 ;named TEST

LABEL        CMPBIT TEST        ;Invert the value of the TEST
                                 ;bit.

                                  CMPBIT INT1ENA    ;Change the interrupt 1
                                                     ;enabled condition.
```

**Syntax**      **COMPL** *Rn*

**Execution**    0 – *Rn* → *Rn*

<b>Options</b>	<u>inst</u>	<u>operands</u>	<u>bytes</u>	<u>cycles</u>	<u>opcode</u>	<u>operation</u>
	COMPL	A	1	8	BB	NOT(A)+1 → (A)
	COMPL	B	1	8	CB	NOT(B)+1 → (B)
	COMPL	<i>Rn</i>	2	6	DB	NOT( <i>Rn</i> )+1 → ( <i>Rn</i> )

**Status Bits**

**Affected**

<b>C</b>	Set on result
<b>N</b>	Set on result
<b>Z</b>	Set on result
<b>V</b>	← 0

**Description**    COMPL provides a logical or 2's complement of the operand. This is the equivalent of an inversion of all the bits followed by an increment. The instruction is useful in doing arithmetic with signed numbers.

**Examples**

```

LABEL      COMPL A                    ;Complement register A

            COMPL B                    ;Complement register B

            COMPL R82                 ;Complement register 82

```

**DAC** *Decimal Add with Carry***Syntax**      **DAC** *s,Rd***Execution**     $(s) + (Rd) + (C) \rightarrow (Rd)$ , Produces a decimal result

<b>Options</b>	<u>inst</u>	<u>operands</u>	<u>bytes</u>	<u>cycles</u>	<u>opcode</u>	<u>operation</u>
	DAC	B,A	1	10	6E	$(B)+(A)+(C) \rightarrow (A)$
	DAC	Rs,A	2	9	1E	$(Rs)+(A)+(C) \rightarrow (A)$
	DAC	Rs,B	2	9	3E	$(Rs)+(B)+(C) \rightarrow (B)$
	DAC	Rs,Rd	3	11	4E	$(Rs)+(Rd)+(C) \rightarrow (Rd)$
	DAC	#iop8,A	2	8	2E	$iop8+(A)+(C) \rightarrow (A)$
	DAC	#iop8,B	2	8	5E	$iop8+(B)+(C) \rightarrow (B)$
	DAC	#iop8,Rd	3	10	7E	$iop8+(Rd)+(C) \rightarrow (Rd)$

**Status Bits**

**Affected**

**C**    1 if value of  $(s) + (Rd) + C > 99$

**N**    Set on result

**Z**    Set on result

**V**    Undefined

**Description**    DAC adds bytes in binary-coded decimal (BCD) form. Each byte is assumed to contain two BCD digits. DAC is not defined for non-BCD operands. DAC with an immediate operand of zero value is equivalent to a conditional increment of the destination operand (increment destination on carry). The DAC instruction automatically performs a decimal adjust on the binary sum of  $(s) + (d) + C$ . The carry bit is added to facilitate adding multi-byte BCD strings, and so the carry bit must be cleared before execution of the first DAC instruction.

**Examples**

```

LABEL      DAC #024h,A      ;If register A contains 097h
                                 ;and C = 0,then the final result
                                 ;put into A is 021h and the carry
                                 ;bit is set

            DAC R55,R7      ;Add the BCD value of R55,
                                 ;and the carry bit to the
                                 ;BCD value of R7

            DAC B,A          ;Add the carry bit to the
                                 ;BCD value in Register B
                                 ;to Register A

```



**Syntax**     **DEC** *Rn*

**Execution**   (*Rn*) - 1 → (*Rn*)

<b>Options</b>	<u>inst</u>	<u>operands</u>	<u>bytes</u>	<u>cycles</u>	<u>opcode</u>	<u>operation</u>
	DEC	A	1	8	B2	(A)-1 → (A)
	DEC	B	1	8	C2	(B)-1 → (B)
	DEC	<i>Rn</i>	2	6	D2	( <i>Rn</i> )-1 → ( <i>Rn</i> )

**Status Bits**

**Affected**

- C**   0 if (*Rn*) decrements from 00h to FFh; 1 otherwise
- N**   Set on result
- Z**   Set on result
- V**   1 if (*Rn*) decrements from 80h to 7Fh; 0 otherwise

**Description**   DEC subtracts 1 from any register. It is useful in counting and addressing byte arrays.

**Examples**

```

LABEL     DEC R102                     ;Decrement R102 by 1

          DEC A                       ;Subtract 1 from the contents of
                                      ;register A

          DEC B                       ;Subtract 1 from the contents of
                                      ;register B

```

**DINT** *Disable Interrupts***Syntax**      **DINT****Execution**    0 → (ST)

<b>Options</b>	<u>inst</u>	<u>operands</u>	<u>bytes</u>	<u>cycles</u>	<u>opcode</u>
DINT	none	2	6	F0 00	

**Status Bits**

<b>Affected</b>	<b>C</b>	← 0
	<b>N</b>	← 0
	<b>Z</b>	← 0
	<b>V</b>	← 0
	<b>IE1</b>	← 0
	<b>IE2</b>	← 0

**Description** DINT simultaneously disables all interrupts. Since the interrupt enable flags are stored in the status register, the POP ST or RETI instructions may re-enable interrupts even though a DINT instruction has been executed. During the interrupt service, the interrupt enable bit is automatically cleared after the old status register value has been pushed onto the stack. The DINT instruction is equal to the LDST #00 instruction.

**Example**      LABEL      DINT      ;Disable high and low level interrupts.



**DJNZ** *Decrement Register and Jump If Not Zero***Syntax** **DJNZ** *Rn,off8***Execution** (Rn) - 1 → (Rn)  
If (Rn) ≠ 0, then PCN + (off8) → (PC), else PCN → (PC)**Type** Single Operand

<b>Options</b>	<u>inst</u>	<u>operands</u>	<u>bytes</u>	<u>cycles</u>	<u>opcode</u>	<u>operation</u>
	DJNZ	A,LABEL	2	10/12	BA	(A)-1 → (A), jump if (A) ≠ 0
	DJNZ	B,LABEL	2	10/12	CA	(B)-1 → (B) jump if (B) ≠ 0
	DJNZ	Rn,LABEL	3	8/10	DA	(Rn)-1 → (Rn) jump if (Rn) ≠ 0

**Status Bits Affected** None**Description** DJNZ is used for looping control. It combines the DEC and the JNZ instructions, providing a faster and more compact instruction. DJNZ does not change the status bits.

<b>Examples</b>	LABEL	DJNZ R15, THERE	;Decrement R15. If R15 ≠ 0, ;jump to THERE
		DJNZ A, AGAIN	;Decrement A; if A ≠ 0, ;jump to AGAIN
		DJNZ B, BACK	;Decrement B; if B ≠ 0, ;jump to BACK

**Syntax**      **DSB** *s,Rd*

**Execution**     $(Rd) - (s) - 1 + (C) \rightarrow (Rd)$  (decimal result)

<b>Options</b>	<u>inst</u>	<u>operands</u>	<u>bytes</u>	<u>cycles</u>	<u>opcode</u>	<u>operation</u>
	DSB	B,A	1	10	6F	$(A)-(B)-1+(C) \rightarrow (A)$
	DSB	Rs,A	2	9	1F	$(A)-(Rs)-1+(C) \rightarrow (A)$
	DSB	Rs,B	2	9	3F	$(B)-(Rs)-1+(C) \rightarrow (B)$
	DSB	Rs,Rd	3	11	4F	$(Rd)-(Rs)-1+(C) \rightarrow (Rd)$
	DSB	#iop8,A	2	8	2F	$(A)-iop8-1+(C) \rightarrow (A)$
	DSB	#iop8,B	2	8	5F	$(B)-iop8-1+(C) \rightarrow (B)$
	DSB	#iop8,Rd	3	10	7F	$(Rd)-iop8-1+(C) \rightarrow (Rd)$

**Status Bits**

<b>Affected</b>	<b>C</b>	1 if no borrow required, 0 if borrow required
	<b>N</b>	Set on result
	<b>Z</b>	Set on result
	<b>V</b>	Undefined

**Description**    DSB performs multiprecision BCD subtraction. A DSB instruction with an immediate operand of zero value is equivalent to a conditional decrement of the destination operand, depending on the carry bit. The carry bit functions as a no borrow bit, so if no borrow in is required, the carry bit should be set to 1. This can be accomplished by executing the SETC instruction. The DSB instruction is undefined for non-BCD operands.

**Example**

```

LABEL      DSB R15,R76          ;R76 minus R15 minus 1 plus
                                   ;the carry bit is stored
                                   ;in R76

          DSB  A,B              ;Register B minus Register
                                   ;A minus 1 plus the carry
                                   ;bit is stored in
                                   ;Register B

          DSB  #0,R5            ;R5 - 1 → R5, if C = 0
                                   ;R5 → R5 if C = 1

```



**Syntax** EINTH

**Execution** 04h → (ST)

<b>Options</b>	<u>inst</u>	<u>operands</u>	<u>bytes</u>	<u>cycles</u>	<u>opcode</u>
EINTH		none	2	6	F0 04

**Status Bits**

**Affected**

<b>C</b>	← 0
<b>N</b>	← 0
<b>Z</b>	← 0
<b>V</b>	← 0
<b>IE1</b>	← 1
<b>IE2</b>	← 0

**Description** EINTH is similar to the EINT instruction but enables only high level (1) interrupts and disables low level interrupts. This assembles to the LDST #04h instruction.

**Example** LABEL EINTH ;All level 1 interrupts are enabled.

**EINTL** *Enable Low Level Interrupts***Syntax** EINTL**Execution** 08h → (ST)

<b>Options</b>	<u>inst</u>	<u>operands</u>	<u>bytes</u>	<u>cycles</u>	<u>opcode</u>
EINTL	none	2	6	F0 08	

**Status Bits**

<b>Affected</b>	<b>C</b>	← 0
	<b>N</b>	← 0
	<b>Z</b>	← 0
	<b>V</b>	← 0
	<b>IE1</b>	← 0
	<b>IE2</b>	← 1

**Description** EINTL is similar to the EINT instruction but enables only low level (2) interrupts while disabling high level interrupts. This assembles to the LDST #08h instruction.

**Example** LABEL EINTL ;All level 2 interrupts are enabled.





**INC** *Increment*

**Syntax**      **INC** *Rn*

**Execution**    (*Rn*) + 1 → (*Rn*)

**Options**

<u>inst</u>	<u>operands</u>	<u>bytes</u>	<u>cycles</u>	<u>opcode</u>	<u>operation</u>
INC	A	1	8	B3	(A)+1 → (A)
INC	B	1	8	C3	(B)+1 → (B)
INC	Rd	2	6	D3	(Rn)+1 → (Rn)

**Status Bits**

- Affected**
- C**    1 if (*Rd*) incremented from FFh to 00h; 0 otherwise
  - N**    Set on result
  - Z**    Set on result
  - V**    1 if (*Rn*) incremented from 7Fh to 80h; 0 otherwise

**Description**    INC increments the value of any register. It is useful for incrementing counters.

**Examples**

```

LABEL    INC A                    ;Increment Register A by 1

          INC B                    ;Increment Register B by 1

          INC R43                 ;Increment Register 43 by 1

```

**Syntax**      **INCW** #off8,Rp

**Execution**    (Rp) + #off8 → (Rp)

<b>Options</b>	<u>inst</u>	<u>operands</u>	<u>bytes</u>	<u>cycles</u>	<u>opcode</u>	<u>operation</u>
	INCW	#off8,Rp	3	11	70	off8+(Rn-1:Rn) → (Rn-1:Rn) off8= signed 8 bit value

**Status Bits**

<b>Affected</b>	<b>C</b>	Set to 1 on carry out of off8 + (Rp)
	<b>N</b>	Set on result
	<b>Z</b>	Set on MSB
	<b>V</b>	( C XOR N ) AND (MSBIT off8 XNOR MSBIT (Rd))

**Description**    INCW increments the value of any register pair by the amount specified. The register pair can be incremented by as much as 127 or decremented by as much as 128. This instruction is useful for incrementing counters into large tables. The off8 is sign extended in order to perform 16-bit two's complement addition. The JC and JNC are commonly used after the INCW instruction for loop control.

**Examples**

```

LABEL      INCW #1,R10                    ;Increment R9:R10 by 1

            INCW #-1,R10                ;Decrement register R9:R10 by 1

            INCW #100,R255              ;Increment register pair
                                         ;R254:R255

```

**Syntax**      **INV** *Rn***Execution**    NOT(*Rn*) → (*Rn*)

<b>Options</b>	<u>inst</u>	<u>operands</u>	<u>bytes</u>	<u>cycles</u>	<u>opcode</u>	<u>operation</u>
	INV	A	1	8	B4	NOT(A) → (A)
	INV	B	1	8	C4	NOT(B) → (B)
	INV	<i>Rn</i>	2	6	D4	NOT( <i>Rn</i> ) → ( <i>Rn</i> )

**Status Bits**

<b>Affected</b>	<b>C</b>	← 0
	<b>N</b>	Set on result
	<b>Z</b>	Set on result
	<b>V</b>	← 0

**Description**    INV performs a one's complement of the operand. A one's complement inverts the value of every bit in the register. A two's complement of the operand can be made by following the INV instruction with an increment (INC), or simply using the COMPL instruction.

**Examples**

LABEL	INV A	Invert Register A (0s become 1s, ;1s become 0s)
	INV B	;Invert Register B
	INV R82	:Invert Register 82

**Syntax**      **JBIT0** *name, off8*

**Execution**    If bit (name) = 0 then PCN + off8 → (PC) else PCN → PC

<b>Options</b>	<u>inst</u>	<u>operands</u>	<u>bytes</u>	<u>cycles</u>	<u>opcode</u>
	JBIT0	Rname	4	10	77
	JBIT0	Pname	4	11	A7

**Note:** Add 2 cycles if jump is taken

#### **Status Bits**

<b>Affected</b>	<b>C</b>	← 0
	<b>N</b>	Set on (s) AND NOT (Rd)
	<b>Z</b>	Set on (s) AND NOT (Rd)
	<b>V</b>	← 0

**Description**    The JBIT0 is an assembler constructed instruction that conveniently jumps to the label if the value of the named bit is zero. This enhances the readability of the software program since the source does not have to specify both the register containing the bit and a mask. The instruction is assembled to BTJZ #iop8,Rd,label or BTJZ #iop8,Pd,label. The name for the bit is defined by the DBIT assembler directive.

**Example**

```

MCDATA      .DBIT 2,P010          ;MC data in bit 2 of
                                       ;SCCR0 (P010) is now
                                       ;named MCDATA

BIT4        .DBIT 4,R3            ;Bit 4 of register 3 is
                                       ;now named BIT4

JBIT0 BIT4,THERE          ;Jump to THERE if bit 4 in
                                       ;register 3 is zero.

JBIT0 MCDATA,HERE        ;Jump to HERE if the MC pin
                                       ;is zero

```

**Syntax**      **JBIT1** *off8***Execution**    bit (name) = 1 then PCN + off8 → (PC) else PCN → (PC)

<b>Options</b>	<u>inst</u>	<u>operands</u>	<u>bytes</u>	<u>cycles</u>	<u>opcode</u>	<u>operation</u>
JBIT1	Rname	4	10	76	register bits	
JBIT1	Pname	4	11	A6	peripheral bits	

**Note:** Add two cycles if Jump is taken.**Status Bits**

<b>Affected</b>	<b>C</b>	← 0
	<b>N</b>	Set on (s) AND (Rd)
	<b>Z</b>	Set on (s) AND (Rd)
	<b>V</b>	← 0

**Description**    The JBIT1 is an assembler constructed instruction that conveniently jumps to the label if the value of the named bit is one. This instruction enhances the readability of the software program since the source does not have to specify both the register containing the bit and a mask. This instruction assembles to BTJO #iop8,Rd,label or BTJO #iop8,Pd,label. The name for the bit is defined by the .DBIT assembler directive.

**Examples**

```
BUSYP      .DBIT 7,P01C      ;Busy bit in PEECTL
           ;(program EEPROM) is now
           ;named BUSYP

BIT0       .DBIT 0,R100     ;Bit 0 of register 100 is
           ;now named BIT0

LABEL     BIT1 BIT0, THERE  ;Jump to THERE if bit 0 in
           ;register 100 is a one.

           JBIT1 BUSYP,HERE  ;Jump to HERE if the program
           ;EEPROM is busy.
```

**Syntax**      **JMP** *off8*

**Execution**    PCN + off8 → (PC)

<b>Options</b>	<u>inst</u>	<u>operands</u>	<u>bytes</u>	<u>cycles</u>	<u>opcode</u>	<u>operation</u>
JMP		off8	2	7	00	PCN+off8 → (PC)

**Status Bits Affected**    None

**Description**    JMP jumps unconditionally to the address specified in the operand. The second byte of the JMP instruction contains the 8-bit relative address of the operand. The operand address must therefore be within -128 to +127 bytes of the location of the instruction following the JMP instruction. The assembler will indicate an error if the target address is beyond -128 to +127 bytes from the next instruction. For a longer jump the BR (branch) or the JMPL instructions can be used.

**Example**

```

LABEL      JMP THERE          ;Load the PC with the address
                                ;of THERE

```

**Syntax**      **JMPL** *XADDR***Execution**    PCN + D → (PC)

<b>Options</b>	<u>inst</u>	<u>operands</u>	<u>bytes</u>	<u>cycles</u>	<u>opcode</u>	<u>operation</u>
	JMPL	label	3	9	89	off16+PCN → (PC)
	JMPL	label(B)	3	11	A9	off16+(B)+PCN → (PC)
	JMPL	off8(Rp)	4	16	F4 E9	(Rn-1:Rn)+off8+PCN → (PC)
	JMPL	@Rd	2	8	99	(Rn-1:Rn)+PCN → (PC)

**Note:** offset = signed 16 bit value  
 off8 = signed 8 bit value  
 (B) = unsigned 8 bit value

**Status Bits****Affected**    None**Description**    JMPL is similar to JMP instruction but generates a 16-bit (instead of 8-bit) signed offset to the program counter.

**Examples**

```

LABEL      JMPL LABEL4            ; (PC) ← PCN + offset
                                 ; offset=LABEL4-PCN

            JMPL 5432h           ; (PC) ← PCN + 5432h

            JMPL LABEL5(B)      ; (PC) ← PCN + off8 + (B)
                                 ; offset=LABEL5 - PCN

            JMPL 1234h(B)       ; (PC) ← PCN + 1234h + (B)

            JMPL @R12           ; (PC) ← PCN + (R11:R12)
                                 ; R12=LSB

            JMPL 56(R10)        ; (PC) ← PCN + 56 + (R9:R10)
                                 ; R10 = LSB

            JMPL -2(R10)        ; (PC) ← PCN -2 + (R9:R10)
                                 ; R10 = LSB

```



**Syntax**      **J<cnd>** *off8*

**Execution**    If tested condition is true, (PC) + off8 → (PC), else PCN → (PC)

**Status Bits**

**Affected**     None

**Description**    The J<cnd> instructions are commonly used after a CMP instruction to branch according to the relative values of the operands tested. After MOV operations, a JZ or JNZ may be used to test if the value moved was equal to zero. JN and JPZ may be used in this case to test the sign bit of the value moved. The program may check the overflow bit V after using an arithmetic instruction with the JV or JNV instructions. All J<cnd> instructions are two bytes in length, and take 5 cycles to execute, unless the jump is taken, in which case the instruction requires 7 cycles.

Instruction	Mnemonic	Opcode	C	N	Z	V	Operation
Jump if Carry	JC	03	1	X	X	X	
Jump if No Carry	JNC	07	0	X	X	X	
Jump if Equal	JEQ	02	X	X	1	X	
Jump if Not Equal	JNE	06	X	X	0	X	
Jump if Non-zero	JNZ	06	X	X	0	X	
Jump if Zero	JZ	02	X	X	1	X	
Jump if Lower	JLO	0F	0	X	0	X	
Jump if Higher or Same	JHS	0B	–	X	–	X	(C = 1) OR (Z = 1)
Jump if Greater	JG	0E	X	–	–	–	—Signed Operation— Z OR (N XOR V) = 0
Jump if Greater or Equal	JGE	0D	X	–	X	–	N XOR V = 0
Jump if Less	JL	09	X	–	X	–	N XOR V = 1
Jump if Less or Equal	JLE	0A	X	–	–	–	Z OR (N XOR V) = 1
Jump if Negative	JN	01	X	1	X	X	
Jump if Positive	JP	04	X	0	0	X	
Jump if Positive or Zero	JPZ	05	X	0	X	X	
Jump if No Overflow	JNV	0C	X	X	X	0	
Jump if Overflow	JV	08	X	X	X	1	

Signed Number Jumps			Unsigned Number Jumps		
Condition	True	False	Condition	True	False
$d < s$	JL	JGE	$d < s$	JLO	JHS
$d \leq s$	JLE	JG	$d \leq s$	2	3
$d = s$	JEQ	JNE	$d = s$	JEQ	JNE
$d \geq s$	JGE	JL	$d \geq s$	JHS	JLO
$d > s$	JG	JLE	$d > s$	3	2
Negative	JN	JPZ			
Positive	JP	1			
Pos or 0	JPZ	JN			

- Notes:** 1) JZ LABEL  
JN LABEL
- 2) JEQ LABEL  
JLO LABEL
- 3) JEQ \$+4  
JHS LABEL

These two-instruction jump sequences are used in place of the single conditional jumps for the numbers shown in the tables. (\$ is the current PC value.)

Status Bit Jumps		
Bits	True	False
C	JC	JNC
N	JN	JPZ
Z	JZ	JNZ
V	JV	JNV

**Examples**

```

LABEL      JNC TABLE      ;If the carry bit is clear,
                                ;jump to TABLE

          JP   HERE        ;If the negative and zero flags
                                ;are clear, jump to HERE

          JZ   NEXT        ;If the zero flag is set, jump
                                ;to NEXT

```

**Syntax** LDSP

**Execution** (B) → (SP)

<b>Options</b>	<u>inst</u>	<u>operands</u>	<u>bytes</u>	<u>cycles</u>	<u>opcode</u>
	LDSP	none	1	7	FD

**Status Bits Affected** None

**Description** LDSP copies the contents of Register B to the Stack Pointer register. Use LDSP to initialize the Stack Pointer.

**Example**

```
MOV      #080h,B           ;Register B = SP value.
LABEL    LDSP              ;Copy Register B to the stack
                               ;pointer.
```

**LDST** *Load Status Register***Syntax** LDST #iop8**Execution** (iop8) → (ST)

<b>Options</b>	<u>inst</u>	<u>operands</u>	<u>bytes</u>	<u>cycles</u>	<u>opcode</u>	<u>operation</u>
	LDST	#iop8	2	6	F0	iop8 → (ST)

**Status Bits**

<b>Affected</b>	<b>C</b>	Set on value loaded
	<b>N</b>	Set on value loaded
	<b>Z</b>	Set on value loaded
	<b>V</b>	Set on value loaded
	<b>IE1</b>	Set on value loaded
	<b>IE2</b>	Set on value loaded

**Description** The LDST copies the immediate value operand to the status register. Any combination of bits may be loaded into the status register using this command. Some instructions such as EINT, EINTL, EINTH or DINT are assembled into this instruction.

**Example**

```

LABEL      LDST #08Ch          ;Copy immediate value to
                                ;the status register and
                                ;set IE2 bit

```

**Syntax**      **MOV** *s,d***Execution**    (*s*) → (*d*)

<b>Options</b>	<u>inst</u>	<u>operands</u>	<u>bytes</u>	<u>cycles</u>	<u>opcode</u>	<u>operation</u>
<b>REGISTER:</b>						
	MOV	A,B	1	9	C0	(A) → (B)
	MOV	A,Rd	2	7	D0	(A) → (Rd)
	MOV	B,A	1	8	62	(B) → (A)
	MOV	B,Rd	2	7	D1	(B) → (Rd)
	MOV	Rs,A	2	7	12	(Rs) → (A)
	MOV	Rs,B	2	7	32	(Rs) → (B)
	MOV	Rs,Rd	3	9	42	(Rs) → (Rd)
	MOV	#iop8,A	2	6	22	iop8 → (A)
	MOV	#iop8,B	2	6	52	iop8 → (B)
	MOV	#iop8,Rd	3	8	72	iop8 → (Rd)
<b>PERIPHERAL:</b>						
	MOV	A,Pd	2	8	21	(A) → (Pd)
	MOV	B,Pd	2	8	51	(B) → (Pd)
	MOV	Rs,Pd	3	10	71	(Rs) → (Pd)
	MOV	Ps,A	2	8	80	(Ps) → (A)
	MOV	Ps,B	2	8	91	(Ps) → (B)
	MOV	Ps,Rd	3	10	A2	(Ps) → (Rd)
	MOV	#iop8,Pd	3	10	F7	iop8 → (Pd)
<b>EXTENDED:</b>						
	MOV	A,@Rn	2	9	9B	(A) → ((Rn-1:Rn))
	MOV	A,label	3	10	8B	(A) → (label)
	MOV	A,label(B)	3	12	AB	(A) → (label+(B))
	MOV	A,off8(SP)	2	7	F2	(A) → (off8+(SP))
	MOV	A,off8(Rd)	4	17	F4 EB	(A) → (off8+(Rd-1:Rd))
	MOV	@Rs,A	2	9	9A	((Rs-1:Rs)) → (A)
	MOV	label,A	3	10	8A	(label) → (A)
	MOV	label(B),A	3	12	AA	(label+(B)) → (A)
	MOV	off8(SP),A	2	7	F1	(off8 + (SP)) → (A)
	MOV	off8(Rn),A	4	17	F4 EA	(off8 +(Rn-1:Rn)) → (A)

**Status Bits**

<b>Affected</b>	<b>C</b>	← 0
	<b>N</b>	Set on value loaded
	<b>Z</b>	Set on value loaded
	<b>V</b>	← 0

**Description**    MOV transfers values within the memory space. Immediate values may be loaded directly into the registers. In extended addressing modes the processor must use register A. A MOV instruction that uses Register A or B as an operand requires fewer bytes. The MOV Pn,Rn and MOV Rn,Pn instructions have the operands reversed when assembled into machine code.

**MOV** *Move***Examples**

```
MOV    A,B           ;Move the contents of Register
                   ;A to Register B

MOV    R32,R105      ;Move the contents of register
                   ;32 to register 105

MOV    #010h,R3      ;Move #010h to register 3

MOV    A,LABEL(B)    ;Move the contents of the A register to the
                   ;location LABEL+B

MOV    A,2Fh(R32)    ;Move the contents of the A register to the
                   ;location 002Fh+(R31:R32)

MOV    @ROF,A        ;Use the contents of the register pair ROE:ROF
                   ;as address. Move the contents of that
                   ;address to register A

MOV    LABEL,A       ;Move the contents of the location at
                   ;LABEL to the A register
```

**Syntax**      **MOVW** *s,Rd*

**Execution**    (*s*) → (*Rd*)

<b>Options</b>	<u>inst</u>	<u>operands</u>	<u>bytes</u>	<u>cycles</u>	<u>opcode</u>	<u>operation</u>
	MOVW	#iop16,Rpd	4	13	88	iop16 → (Rd-1:Rd)
	MOVW	Rps,Rpd	3	12	98	(Rs-1:Rs) → (Rd-1:Rd)
	MOVW	#off8(Rs),Rpd	5	20	F4 E8	(Rs-1:Rs)+off8 → (Rd-1:Rd)
	MOVW	#iop16(B),Rpd	4	15	A8	(B) + iop16 → (Rd-1:Rd)

### Status Bits

<b>Affected</b>	<b>C</b>	
	<b>N</b>	Set on MSB moved
	<b>Z</b>	Set on MSB moved
	<b>V</b>	← 0

**Description**    MOVW moves a two-byte value to the register pair indicated by the destination register number. (Note that Rpd should be greater than 0.) The destination points to the LSB of the destination register pair. The source may be a 16-bit constant, another register pair, or an indexed address. For the Indexed address, the source must be of the form "#ADDR(B)" where ADDR is a 16-bit constant or address. This 16-bit value is added (via 16-bit addition) to the contents of the B register, and the result placed in the destination register pair. This stores an indexed address into a register pair, for use later in indirect addressing mode. This is not to be confused with the extended addressing instruction LABEL(B).

**Examples**

```

LABEL    MOVW #1234h,R3      ;1234h → (R2:R3)
          MOVW R5,R3         ;(R4:R5) → (R2:R3)
          ;R5,R3 = LSB

          MOVW #TAB(B),R3    ;TAB + (B) → (R2:R3)
          ;R3 = LSB

          MOVW #127(R200),R34 ;127 + (R199:R200) →
          ;(R33:R34)

          MOVW #-128(R200),R34 ;(R199:R200) - 128 →
          ;(R33:R34)

```

**MPY** *Multiply*

**Syntax**      **MPY** *s,Rn*

**Execution**     $(s) \times (Rn) \rightarrow (A:B)$  Result always stored in A,B    A = MSB

<b>Options</b>	<u>inst</u>	<u>operands</u>	<u>bytes</u>	<u>cycles</u>	<u>opcode</u>	<u>operation</u>
MPY	B,A		1	47	6C	(A) X (B) $\rightarrow$ (A:B)
MPY	Rs,A		2	46	1C	(A) X (Rs) $\rightarrow$ (A:B)
MPY	Rs,B		2	46	3C	(B) X (Rs) $\rightarrow$ (A:B)
MPY	Rs,Rd		3	48	4C	(Rd) X (Rs) $\rightarrow$ (A:B)
MPY	#iop8,A		2	45	2C	(A) X iop8 $\rightarrow$ (A:B)
MPY	#iop8,B		2	45	5C	(B) X iop8 $\rightarrow$ (A:B)
MPY	#iop8,Rd		3	47	7C	(Rd) X iop8 $\rightarrow$ (A:B)

**Status Bits**

**Affected**

- C**       $\leftarrow 0$
- N**      Set on MSB of results (Register A)
- Z**      Set on MSB of results (Register A)
- V**       $\leftarrow 0$

**Description**    MPY performs an 8-bit multiply for a general source and destination operand. The 16-bit result is placed in the A, B register pair with the most significant byte in A. Multiplying by a power of two is a convenient means of performing double-byte shifts. If a double-byte shift is three places or less, then it may be faster to use RLC or RRC instead of multiply. If a single byte needs shifting then it is almost always faster to use RLC or RRC.

**Examples**

```

LABEL      MPY R3,A                    ;Multiply (R3) with (A), store
                                         ;result in A, B register pair

            MPY #032h,B               ;Multiply 32h with (B), store
                                         ;in register pair A, B

            MPY R12,R7                ;Multiply (R12) with (R7) and
                                         ;store in A, B register pair
    
```



**Syntax**        **NOP**

**Execution**    (PC) + 1 → (PC)

**Options**       inst    operands    bytes cycles opcode  
NOP       none            1       7       FF

**Status Bits Affected**    None

**Description**    NOP is useful as a pad instruction during program development, to "patch out" unwanted or erroneous instructions or to leave room for code changes during development. It is also useful in software timing loops.

**Example**        LABEL        NOP

**Syntax** OR *s,Rd*

**Execution** (s) OR (Rd) → (Rd)

<b>Options</b>	<u>inst</u>	<u>operands</u>	<u>bytes</u>	<u>cycles</u>	<u>opcode</u>	<u>operation</u>
	OR	A,Pd	2	9	84	(A) OR (Pd) → (Pd)
	OR	B,Pd	2	9	94	(B) OR (Pd) → (Pd)
	OR	B,A	1	8	64	(B) OR (A) → (A)
	OR	Rs,A	2	7	14	(Rs) OR (A) → (A)
	OR	Rs,B	2	7	34	(Rs) OR (B) → (B)
	OR	Rs,Rd	3	9	44	(Rs) OR (Rd) → (Rd)
	OR	#iop8,A	2	6	24	iop8 OR (A) → (A)
	OR	#iop8,B	2	6	54	iop8 OR (B) → (B)
	OR	#iop8,Rd	3	8	74	iop8 OR (Rd) → (Rd)
	OR	#iop8,Pd	3	10	A4	iop8 OR (Pd) → (Pd)

**Status Bits**

**Affected**

<b>C</b>	← 0
<b>N</b>	Set on result
<b>Z</b>	Set on result
<b>V</b>	← 0

**Description** OR logically ORs the two operands. The OR operation is used to set bits in a register. If a register needs a 1 in the destination then a 1 is placed in the corresponding bit location in the source operand.

**Examples**

```

LABEL    OR  A,R12           ;OR the A Register with R12,
                               ;store in R12

                               OR  #00Fh,A       ;Set lower nibble of A to 1s,
                               ;leave upper nibble unchanged

                               OR  R8,B         ;OR (R8) with (B), store in B

```

**Syntax** POP *d*

**Execution** ((SP)) → (*d*)  
 (SP) - 1 → (SP)  
 (Move value then decrement SP)

<b>Options</b>	<u>inst</u>	<u>operands</u>	<u>bytes</u>	<u>cycles</u>	<u>opcode</u>	<u>operation</u>
	POP	A	1	9	B9	((SP)) → (A); (SP) - 1 → (SP)
	POP	B	1	9	C9	((SP)) → (B); (SP) - 1 → (SP)
	POP	Rn	2	7	D9	((SP)) → (Rn); (SP) - 1 → (SP)
	POP	ST	1	8	FC	((SP)) → (ST); (SP) - 1 → (SP)

**Status Bits**

**Affected**

<b>C</b>	← 0
<b>N</b>	Set on value POPed
<b>Z</b>	Set on value POPed
<b>V</b>	← 0

**Note:** POP ST affects all status bits.

**Description** POP pulls a value from the top of the stack. The stack can be used to save or pass values between routines. The status register may be replaced with the contents on the stack by the statement POP ST. This one-byte instruction is usually executed in conjunction with a previously performed PUSH ST instruction.

**Examples**

```

LABEL    POP R32    ;Load R32 with value on top of stack

        POP ST     ;Load status register with
                   ;value on top of stack
  
```

**Syntax**      **PUSH** *s***Execution**     $(SP) + 1 \rightarrow (SP)$   
                   $(s) \rightarrow ((SP))$   
                  (Increment SP then move value)

<b>Options</b>	<u>inst</u>	<u>operands</u>	<u>bytes</u>	<u>cycles</u>	<u>opcode</u>	<u>operation</u>
	PUSH	A	1	9	B8	$(SP) + 1 \rightarrow (SP); (A) \rightarrow ((SP))$
	PUSH	B	1	9	C8	$(SP) + 1 \rightarrow (SP); (B) \rightarrow ((SP))$
	PUSH	Rn	2	7	D8	$(SP) + 1 \rightarrow (SP); (Rn) \rightarrow ((SP))$
	PUSH	ST	1	8	FB	$(SP) + 1 \rightarrow (SP); (ST) \rightarrow ((SP))$

**Status Bits**

**Affected**

**C**       $\leftarrow 0$

**N**      Set on value PUSHed

**Z**      Set on value PUSHed

**V**       $\leftarrow 0$

**Note:** Status bits are unchanged for PUSH ST**Description**    PUSH places a value on the top of the stack. The stack is used to save or pass values between routines.

The status register may be pushed on the stack with the statement PUSH ST. This one-byte instruction is usually executed in conjunction with a subsequently performed POP ST instruction.

**Examples**

```
LABEL      PUSH A                            ;Move (A) to top of stack

            PUSH ST                    ;Move status to top of stack
```

**Syntax**      **RL** *Rn*

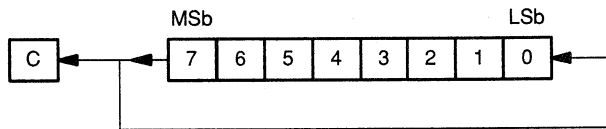
**Execution**    Bit(*n*) → Bit(*n*+1)  
 Bit(7) → Bit(0) and carry

<b>Options</b>	<u>inst</u>	<u>operands</u>	<u>bytes</u>	<u>cycles</u>	<u>opcode</u>
	RL	A	1	8	BE
	RL	B	1	8	CE
	RL	Rn	2	6	DE

**Status Bits Affected**

<b>C</b>	Set to bit 7 of the original operand
<b>N</b>	Set on result
<b>Z</b>	Set on result
<b>V</b>	← 0

**Description**    RL circularly shifts the destination contents one bit to the left. The MSb is shifted into the LSB; the carry bit is also set to the original MSb value.



For example, if Register B contains the value 93h, then RL changes the contents of B to 27h and sets the carry bit.

**Examples**

```

LABEL      RL   R102

            RL   A

            RL   B
  
```

**RLC** *Rotate Left Through Carry***Syntax**     **RLC** *Rn*

**Execution**   Bit(n) → Bit(n+1)  
                   Carry → Bit(0)  
                   Bit(7) → Carry

**Options**

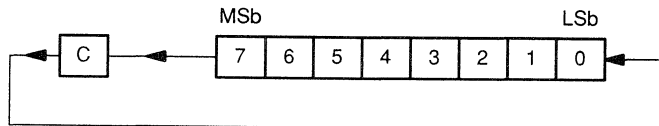
<u>inst</u>	<u>operands</u>	<u>bytes</u>	<u>cycles</u>	<u>opcode</u>
RLC	A	1	8	BF
RLC	B	1	8	CF
RLC	Rn	2	6	DF

**Status Bits**

**Affected**

<b>C</b>	Set to bit 7 of the original operand
<b>N</b>	Set on result
<b>Z</b>	Set on result
<b>V</b>	← 0

**Description**   RLC circularly shifts the destination contents one bit to the left and through the carry. The original carry bit contents shift into the LSb, and the original MSb shifts into the carry bit.



For example, if Register B contains the value 93h and the carry bit is a zero, then the RLC instruction changes the operand value to 26h and the carry to one.

Rotating left effectively multiplies the value by 2. Using multiple rotates, any power of 2 (2, 4, 8, 16,...) can be achieved. This type of multiply can be faster than the MPY (multiply) instruction. This instruction is also useful in rotates where a value is contained in more than one byte such as an address or in multiplying a large multibyte number by 2. Care must be taken to assure that the carry is at the proper value. The SETC or CLRC instructions may be used to setup the correct value.

**Examples**

```

LABEL     RLC   R72

          RLC   A

          RLC   B

```

**Syntax** RR Rn

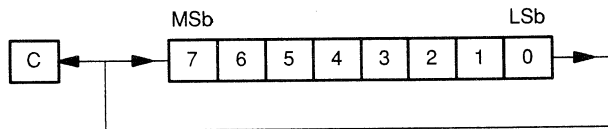
**Execution** Bit(n+1) → Bit(n)  
Bit(0) → Bit (7) and carry

<b>Options</b>	<u>inst</u>	<u>operands</u>	<u>bytes</u>	<u>cycles</u>	<u>opcode</u>
	RR	A	1	8	BC
	RR	B	1	8	CC
	RR	Rn	2	6	DC

**Status Bits Affected**

**C** Set to bit 0 of the original value  
**N** Set on result  
**Z** Set on result  
**V** ← 0

**Description** RR circularly shifts the destination contents one bit to the right. The LSb is shifted into the MSb, and the carry bit is also set to the original LSb value.



For example, if Register B contains the value 93h, then the "RR B" instruction changes the contents of B to C9h and sets the carry status bit.

**Example** LABEL RR A

**RRC** *Rotate Right Through Carry***Syntax** RRC *Rn*

**Execution** Bit(n+1) → Bit(n)  
 Carry → Bit(7)  
 Bit(0) → Carry

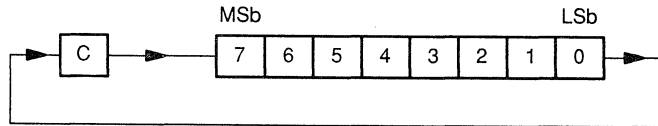
<b>Options</b>	<u>inst</u>	<u>operands</u>	<u>bytes</u>	<u>cycles</u>	<u>opcode</u>
	RRC	A	1	8	BD
	RRC	B	1	8	CD
	RRC	Rn	2	6	DD

**Status Bits**

**Affected**

<b>C</b>	Set to bit 0 of the original value
<b>N</b>	Set on result
<b>Z</b>	Set on result
<b>V</b>	← 0

**Description** RRC circularly shifts the destination contents one bit to the right through the carry. The carry bit contents shift into the MSb, and the LSb shifts into the carry bit.



For example, if Register B contains the value 93h and the carry bit is zero, then RRC changes the operand value to 49h and sets the carry bit.

When the carry bit is 0 this instruction effectively divides the value by two. A value of 80h becomes 40h. By repetitive use of this instruction, the value can be divided by any power of two. Care must be taken to assure the correct value in the carry bit.

**Example** LABEL RRC R32



<b>Syntax</b>	RTI										
<b>Execution</b>	((SP)) → (PC LSB) (SP) - 1 → (SP) ((SP)) → (PC MSB) (SP) - 1 → (SP) ((SP)) → (ST) (SP) - 1 → (SP)										
<b>Options</b>	<table><thead><tr><th><u>inst</u></th><th><u>operands</u></th><th><u>bytes</u></th><th><u>cycles</u></th><th><u>opcode</u></th></tr></thead><tbody><tr><td>RTI</td><td>none</td><td>1</td><td>12</td><td>FA</td></tr></tbody></table>	<u>inst</u>	<u>operands</u>	<u>bytes</u>	<u>cycles</u>	<u>opcode</u>	RTI	none	1	12	FA
<u>inst</u>	<u>operands</u>	<u>bytes</u>	<u>cycles</u>	<u>opcode</u>							
RTI	none	1	12	FA							
<b>Status Bits Affected</b>	Status register is loaded from the stack										
<b>Description</b>	RTI is typically the last instruction executed in an interrupt service routine. RTI restores the status register to its state immediately before the interrupt occurred and branches back to the program at the instruction boundary where the interrupt occurred. In an interrupt routine, there must be an equal number of POPs and PUSHs so that the stack is pointing to the correct return address and not some other data.										
<b>Example</b>	<code>LABEL RTI ;Return to main program from interrupt routine</code>										

**Syntax**      **RTS**

**Execution**    ((SP)) → (PC LSB)  
                   (SP) - 1 → (SP)  
                   ((SP)) → (PC MSB)  
                   (SP) - 1 → (SP)

<b>Options</b>	<u>inst</u>	<u>operands</u>	<u>bytes</u>	<u>cycles</u>	<u>opcode</u>
RTS		none	1	9	F9

**Status Bits Affected**    None

**Description**    RTS is typically the last instruction executed in a subroutine. RTS branches to the location immediately following the subroutine call instruction. In the called subroutine there must be an equal number of POPs and PUSHes so that the stack is pointing to the return address and not some other data.

**Example**        LABEL RTS        ;Return to main program from subroutine

**Syntax**      **SBB** *s,Rd*

**Execution**     $(Rd) - (s) - 1 + (C) \rightarrow (Rd)$

<b>Options</b>	<u>inst</u>	<u>operands</u>	<u>bytes</u>	<u>cycles</u>	<u>opcode</u>	<u>operation</u>
	SBB	B,A	1	8	6B	$(A) - (B) - 1 + (C) \rightarrow (A)$
	SBB	Rs,A	2	7	1B	$(A) - (Rs) - 1 + (C) \rightarrow (A)$
	SBB	Rs,B	2	7	3B	$(B) - (Rs) - 1 + (C) \rightarrow (B)$
	SBB	Rs,Rd	3	9	4B	$(Rd) - (Rs) - 1 + (C) \rightarrow (Rd)$
	SBB	#iop8,A	2	6	2B	$(A) - iop8 - 1 + (C) \rightarrow (A)$
	SBB	#iop8,B	2	6	5B	$(B) - iop8 - 1 + (C) \rightarrow (B)$
	SBB	#iop8,Rd	3	8	7B	$(Rd) - iop8 - 1 + (C) \rightarrow (Rd)$

**Status Bits**

**Affected**

- C**    Set to 1 if no borrow; 0 otherwise
- N**    Set on result
- Z**    Set on result
- V**     $((C \text{ XOR } N) \text{ AND } (\text{Source}[\text{Bit } 7] \text{ XOR } \text{Destination}[\text{Bit } 7]))$

**Description**    SBB performs multibyte 2's complement subtraction. An SBB instruction with an immediate operand of zero value is equivalent to a conditional decrement of the destination operand, dependent on the carry value. If  $(s) = 0$  and  $(C) = 0$  then  $(Rd)$  is decremented. A borrow occurs if the result is negative. In this case, the carry bit is set to 0. The carry bit can be thought of as the "no-borrow" bit.

**Examples**

```

LABEL    SBB    #023h,B    ;Subtract 23h from (B), sub-
                         ;tract 1, add the carry bit
                         ;and store in Register B

                 SUB    R3,R21    ;R20:R21 and R2:R3 contain 1
                 SBB    R2,R20    ;bit numbers. SUB subtracts
                         ;the LSB and the SBB will
                         ;use the carry as a borrow
                         ;during the subtract of
                         ;the MSB.

```

**SBIT0** *Set Bit to 0*

**Syntax**      **SBIT0** *name*

**Execution**    0 → <name>

<b>Options</b>	<u>inst</u>	<u>operands</u>	<u>bytes</u>	<u>cycles</u>	<u>opcode</u>	<u>operation</u>	
	SBIT0	Rname	3	8	73	0 → <bit>	Register bits
	SBIT0	Pname	3	10	A3	0 → <bit>	Peripheral bits

**Status Bits**

**Affected**

<b>C</b>	← 0
<b>N</b>	Set on result
<b>Z</b>	Set on result
<b>V</b>	← 0

**Description**    SBIT0 is an assembler constructed instruction that conveniently clears the value of the named bit without having to specify a register or mask. This enhances the readability of the software program. This instruction assembles to the instructions AND #iop8,Rd or AND #iop8,Pd. The name for the bit is defined by the .DBIT assembler directive.

**Examples**

```

INT1ENA  .DBIT 7,P01C      ;The interrupt 1 enable
                               ;bit is now
                               ;named INT1ENA

TEST     .DBIT 4,R33      ;Bit 4 of register 33
                               ;is now named TEST

LABEL   SBIT0 TEST       ;Clears the value of the
                               ;TEST bit

                               SBIT0 INT1ENA  ;Disables Interrupt 1
    
```

**Syntax**      **SBIT1** *name*

**Execution**    1 → <name>

<b>Option</b>	<u>inst</u>	<u>operands</u>	<u>bytes</u>	<u>cycles</u>	<u>opcode</u>	<u>operation</u>
	SBIT1	Rname	3	8	74	1 → <bit> Register bits
	SBIT1	Pname	3	10	A4	1 → <bit> Peripheral bits

**Status Bits**

**Affected**

<b>C</b>	← 0
<b>N</b>	Set on result
<b>Z</b>	Set on result
<b>V</b>	← 0

**Description** SBIT1 is an assembler constructed instruction that conveniently sets the value of the named bit without having to specify a register or mask. This enhances the readability of the software program. This instruction assembles to the instructions OR #iop8,Rd or OR #iop8,Pd. The name for the bit is defined by the .DBIT assembler directive.

**Examples**

```
INT1ENA    .DBIT 7,P01C           ;The interrupt 1 enable bit
                                     ;is now named INT1ENA

TEST       .DBIT 4,R33           ;Bit 4 of register 33 is now
                                     ;named TEST

LABEL      SBIT1 TEST            ;Sets the value of the TEST
                                     ;bit to 1

                                     SBIT1 INT1ENA        ;Enables Interrupt 1
```

**SETC** *Set Carry***Syntax**      **SETC****Execution**    1 → (C)

<b>Options</b>	<u>inst</u>	<u>operands</u>	<u>bytes</u>	<u>cycles</u>	<u>opcode</u>
	SETC	none	1	7	F8

**Status Bits**

<b>Affected</b>	<b>C</b>	← 1
	<b>N</b>	← 0
	<b>Z</b>	← 1
	<b>V</b>	← 0

**Description**    SETC sets the carry flag. May be used before an arithmetic or rotate instruction. The IE1 and IE2 enable bits are not affected.

**Example**

```

LABEL      SETC                    ;Set the carry bit in the status
                                  ;register
                                  ;Status register = 0Ah

```

**Syntax** STSP

**Execution** (SP) → (B)

**Options**

<u>inst</u>	<u>operands</u>	<u>bytes</u>	<u>cycles</u>	<u>opcode</u>
STSP	none	1	8	FE

**Status Bits Affected** None

**Description** STSP copies the contents of the stack pointer to Register B. This instruction can be used to test the stack size. The indexed addressing mode may be used to reference operands on the stack after executing this instruction.

**Example**

```
LABEL    STSP        ;Copy the contents of stack pointer
                    ;to Register B
```

**SUB** *Subtract***Syntax** SUB *s,Rd***Execution** (Rd) – (s) → (Rd)

<b>Options</b>	<u>inst</u>	<u>operands</u>	<u>bytes</u>	<u>cycles</u>	<u>opcode</u>	<u>operation</u>
	SUB	B,A	1	8	6A	(A) – (B) → (A)
	SUB	Rs,A	2	7	1A	(A) – (Rs) → (A)
	SUB	Rs,B	2	7	3A	(B) – (Rs) → (B)
	SUB	Rs,Rd	3	9	4A	(Rd) – (Rs) → (Rd)
	SUB	#iop8,A	2	6	2A	(A) – iop8 → (A)
	SUB	#iop8,B	2	6	5A	(B) – iop8 → (B)
	SUB	#iop8,Rd	3	8	7A	(Rd) – iop8 → (Rd)

**Status Bits**

<b>Affected</b>	<b>C</b>	Set to 1 if no borrow, otherwise set to 0
	<b>N</b>	Set on result
	<b>Z</b>	Set on result
	<b>V</b>	((C XOR N) AND (Source[Bit 7] XOR Destination[Bit 7]))

**Description** SUB performs 2's complement subtraction. The carry bit is set to 0 if a borrow is required. The carry bit could be thought of as a "no-borrow" bit in this case.

**Examples**

```

LABEL    SUB R19,B           ;(B) minus (R19) is
                                ;stored in B

        SUB 076h,A          ;(A) minus 076h is stored
                                ;in A

        SUB R4,R9           ;(R9) minus (R4) is stored
                                ;in R9

```



**Syntax**      **SWAP** *Rn*

**Execution**    Bits (7,6,5,4, / 3,2,1,0) → Bits (3,2,1,0, / 7,6,5,4)

<b>Options</b>	<u>inst</u>	<u>operands</u>	<u>bytes</u>	<u>cycles</u>	<u>opcode</u>
SWAP	A	1	11	B7	
SWAP	B	1	11	C7	
SWAP	Rn	2	9	D7	

**Status Bits**

**Affected**

<b>C</b>	Set to bit 4 of original register or Bit 0 of result register
<b>N</b>	Set on results
<b>Z</b>	Set on results
<b>V</b>	← 0

**Description**    SWAP exchanges the first four bits with the second four bits. This instruction is equivalent to four consecutive RL (rotate left) instructions. It is especially useful for packed BCD operations.

**Examples**

```

LABEL      SWAP R45      ;Switch Lo and Hi nibbles of R45

            SWAP A        ;Switch Lo and Hi nibbles of A

            SWAP B        ;Switch Lo and Hi nibbles of B

```

**Syntax**      **TRAP** *n*    where *n* = 0 thru 15

**Execution**    (SP) + 1      → (SP)  
                   (PC MSB)    → ((SP))  
                   (SP) + 1      → (SP)  
                   (PC LSB)    → ((SP))  
                   (Entry vector → (PC)

**Options**

inst	operands	bytes	cycles	opcode	Entry-vector	
					MSB	LSB
TRAP	0	1	14	EF	7FDE	7FDF
TRAP	1	1	14	EE	7FDC	7FDD
TRAP	2	1	14	ED	7FDA	7FDB
TRAP	3	1	14	EC	7FD8	7FD9
TRAP	4	1	14	EB	7FD6	7FD7
TRAP	5	1	14	EA	7FD4	7FD5
TRAP	6	1	14	E9	7FD2	7FD3
TRAP	7	1	14	E8	7FD0	7FD1
TRAP	8	1	14	E7	7FCE	7FCF
TRAP	9	1	14	E6	7FCC	7FCD
TRAP	10	1	14	E5	7FCA	7FCB
TRAP	11	1	14	E4	7FC8	7FC9
TRAP	12	1	14	E3	7FC6	7FC7
TRAP	13	1	14	E2	7FC4	7FC5
TRAP	14	1	14	E1	7FC2	7FC3
TRAP	15	1	14	E0	7FC0	7FC1

**Status Bits**

**Affected**    None

**Description**    Trap is a one-byte subroutine call. The operand <*n*> is a trap number that identifies a location in the trap vector table, addresses 07FC0h to 07FDFh in memory. The contents of the two-byte vector location form a 16-bit trap vector to which a subroutine call is performed. The TRAP is more efficient than a CALL when invoking the same routine more than once because less bytes are needed. The subroutine addresses are stored like all other addresses in memory, with the least significant byte in the higher-addressed location, as indicated above.

**Example**

```

LABEL            TRAP 0                            ;Execute subroutine at TRAPONE

.sect trap,       07FC0h                         ;Define section starting
                                                 ;at 7FC0h

.word TRAP15,TRAP14                            ;Define TRAPS 15 AND 14
                                                 ;subroutine entry points

```

**Syntax**     **TST** [A],[B]

**Execution**   C,N,Z,V bits affected

<b>Options</b>	<u>inst</u>	<u>operands</u>	<u>bytes</u>	<u>cycles</u>	<u>opcode</u>
	TST	A	1	9	B0
	TST	B	1	10	C6

**Status Bits**

**Affected**

<b>C</b>	← 0
<b>N</b>	Set or cleared based on operand
<b>Z</b>	Set or cleared based on operand
<b>V</b>	← 0

**Description**   TST sets the status bits according to the value in Register A or B. This allows conditional Jumps on the value in the register.

**Example**

```

LABEL      TST A          ;Check for zero and negative
           ;conditions in register A

           TST B          ;Check for zero and negative
           ;conditions in register B

```

**Syntax** XCHB *Rn***Execution** (B)  $\longleftrightarrow$  (Rn)

<b>Options</b>	<u>inst</u>	<u>operands</u>	<u>bytes</u>	<u>cycles</u>	<u>opcode</u>	<u>operation</u>
	XCHB	A	1	10	B6	(A) $\leftarrow$ $\rightarrow$ (B)
	XCHB	B	1	10	C6	(B) $\leftarrow$ $\rightarrow$ (B) (TST B)
	XCHB	Rn	2	8	D6	(Rn) $\leftarrow$ $\rightarrow$ (B)

**Status Bits**

**Affected**

**C**  $\leftarrow$  0

**N** Set on original contents of B

**Z** Set on original contents of B

**V**  $\leftarrow$  0

**Description** XCHB exchanges a register with Register B without going through an intermediate location. The XCHB instruction with the B Register as the operand is equivalent to the TST B instruction.

**Examples**

```

LABEL    XCHB A        ;Exchange Register B with
                ;Register A

                XCHB R3    ;Exchange Register B with R3

```

**Syntax** XOR *s,d*

**Execution** (s) XOR (d) → (d)

<b>Options</b>	<u>inst</u>	<u>operands</u>	<u>bytes</u>	<u>cycles</u>	<u>opcode</u>	<u>operation</u>
	XOR	A,Pd	2	9	85	(A) XOR (Pd) → (Pd)
	XOR	B,A	1	8	65	(B) XOR (A) → (A)
	XOR	B,Pd	2	9	95	(B) XOR (Pd) → (Pd)
	XOR	Rs,A	2	7	15	(Rs) XOR (A) → (A)
	XOR	Rs,B	2	7	35	(Rs) XOR (B) → (B)
	XOR	Rs,Rd	3	9	45	(Rs) XOR (Rd) → (Rd)
	XOR	#iop8,A	2	6	25	iop8 XOR (A) → (A)
	XOR	#iop8,B	2	6	55	iop8 XOR (B) → (B)
	XOR	#iop8,Rd	3	8	75	iop8 XOR (Rd) → (Rd)
	XOR	#iop8,Pd	3	10	A5	iop8 XOR (Pd) → (Pd)

**Status Bits**

**Affected**

<b>C</b>	← 0
<b>N</b>	Set on result
<b>Z</b>	Set on result
<b>V</b>	← 0

**Description** XOR performs a bit-wise exclusive OR operation on the operands. The XOR instruction can be used to complement bits in the destination operand. This operation can also toggle a bit in a register. If the bit value in the destination needs to be the opposite from what it currently is, then the source should contain a 1 in that bit location.

**Examples**

```

LABEL      XOR R98,R125      ;XOR (R98) with (R125),
                                ;store in R125

          XOR #01,R20        ;Toggle bit 0 in R20

          XOR B,A            ;XOR (B) with (A), store
                                ;in register A
  
```



Introduction	1
Assembly Language Instruction Set	13
TMS370 Family Devices	2
Design Aids	14
CPU and Memory Organization	3
Development Support	15
System and Digital I/O Configuration	4
Electrical Specifications	16
Interrupts and System Reset	5
Customer Information	17
EEPROM Modules	6
Appendices	A-H
Timer 1 Module	7
Timer 2 Module	8
Serial Communications Interface (SCI) Port	9
Serial Peripheral Interface (SPI) Module	10
Analog-to-Digital Converter Module	11
TMS370 Programmable Acquisition and Control Timer	12





This chapter contains sample TMS370 applications to aid the programmer in system development and covers the following topics:

<b>Section</b>	<b>Page</b>
14.1 Microcomputer Interface Example .....	14-2
14.2 Programming with the TMS370 Family .....	14-16
14.3 Serial Communications .....	14-20
14.4 Analog/Digital Converter .....	14-24
14.5 PACT Module .....	14-25
14.6 Sample Routines .....	14-33

## 14.1 Microcomputer Interface Example

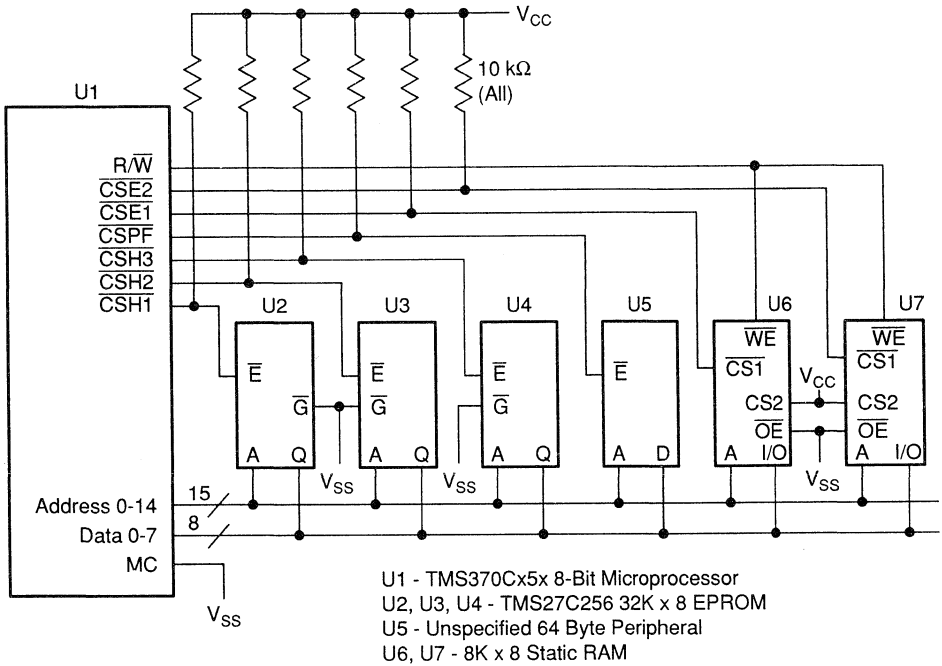
14

The following exercise is one method of interfacing the TMS370 family with common memory. The goals of this example are as follows:

- ❑ Interface with the maximum amount of memory
- ❑ Use the least expensive logic elements
- ❑ Use a minimum amount of parts
- ❑ Maintain sufficient system speed

The example shown in Figure 14–1 illustrates a balance of these goals. In this case, the TMS370C850 is used with three TMS27C256s to provide 96K bytes of EPROM and two HM6264LP-15s to give 16K of RAM. Peripheral devices using up to 64 bytes of memory space may also interface to the bus. This gives a total memory of 116K; 112K of external memory and 4K memory internal to the microcomputer. The current timings for the EPROM and RAM memory devices are given. Since specifications change from time to time, always check the latest data sheets for the devices used.

Figure 14-1. Microcomputer Interface Example



The devices used in the TMS370/Interface Example Circuit are:

TMS370C850 – 8-bit CMOS microcomputer

TMS27C256 – 32 K x 8 EPROM

HM6264LP – Hitachi 8K x 8 RAM

The timing specifications for the TMS27C256-30 EEPROM devices are as follows:

Symbol	Description	Min	Max
$t_a(A)$	Access time from address	—	300 ns
$t_a(E)$	Access time from enable	—	300 ns
$t_{dis}$	Output disable time	0 ns	105 ns
$t_v(A)$	Output data valid after addr. change	0 ns	—

Reference: 1986 TI MOS Memory Data book

The timing specifications for the HM6264P-15 RAM device are as follows:

<u>Symbol</u>	<u>Description</u>	<u>Min</u>	<u>Max</u>
t <sub>AA</sub>	Address access time	—	150 ns
t <sub>OHZ</sub>	Out disable to output in high Z	0	
t <sub>C01</sub>	Chip selection to output	—	150 ns
t <sub>HZ1</sub>	Chip Deselection to output in high Z	0 ns	50 ns
t <sub>CW</sub>	Chip select to end of write	100 ns	—
t <sub>WP</sub>	Write pulse width	90 ns	—
t <sub>DW</sub>	Data to write time overlap	60 ns	—
t <sub>DH</sub>	Data hold from write time	0 ns	—

Reference: #M10 Hitachi Memory Data Book

The TMS370 family is designed to use a clock speed of 20 MHz. This means that slower peripheral devices may not be able to react quickly enough to operate properly. The TMS370C050 has the ability to insert wait states to slow the bus accesses in three different ways. The first way uses the AUTO-WAIT DISABLE bit at SCCR1.4 to add 1 wait state to all external accesses. The second way uses the PF AUTOWAIT bit at SCCR0.5 to add 2 wait states to the external peripheral file access in order to accommodate slower devices. The third way allows the external device to pull the  $\overline{\text{WAIT}}$  pin low and add as many wait states as required to service the slower device. Table 14–1 shows the various combinations.

**Table 14–1. Wait State Control Bits**

Wait State Control Bits		No. of Clock Cycles per Access	
PF Auto Wait	Autowait Disable	Peripheral File	External Memory
0	0	3	3
0	1	2	2
1	0	4	3
1	1	4	2

Table 14–2. Memory Interface Timing

Symbol	Parameter	Min (nS)	Max (nS)
$t_c$ †	CLKOUT (system clock) cycle time	200	2000
$t_w(\text{COH})$	CLKOUT high pulse duration	$0.5t_c$	$0.5t_c+20$
$t_w(\text{COL})$	CLKOUT low pulse duration	$0.5t_c-20$	$0.5t_c$
$t_d(\text{COL-A})$	Delay time, CLKOUT low to address, $\overline{R/\overline{W}}$ , and $\overline{\text{OCF}}$		$0.25t_c+40$
$t_v(\text{A})$	Address valid to $\overline{\text{EDS}}$ , $\overline{\text{CSE1}}$ , $\overline{\text{CSE2}}$ , $\overline{\text{CSH1}}$ , $\overline{\text{CSH2}}$ , $\overline{\text{CSH3}}$ , and $\overline{\text{CSPF}}$ low	$0.5t_c-50$	
$t_{su}(\text{D})$	Write data setup time to $\overline{\text{EDS}}$ high	$0.75t_c-40$ ‡	
$t_h(\text{EH-A})$	Address, $\overline{R/\overline{W}}$ , and $\overline{\text{OCF}}$ hold time from $\overline{\text{EDS}}$ , $\overline{\text{CSE1}}$ , $\overline{\text{CSE2}}$ , $\overline{\text{CSH1}}$ , $\overline{\text{CSH2}}$ , $\overline{\text{CSH3}}$ , and $\overline{\text{CSPF}}$ high	$0.5t_c-40$	
$t_h(\text{EH-D})\text{W}$	Write data hold time from $\overline{\text{EDS}}$ high	$0.75t_c+15$	
$t_d(\text{DZ-EL})$	Delay time, data bus high impedance to $\overline{\text{EDS}}$ low (read cycle)	$0.25t_c-30$	
$t_d(\text{EH-D})$	Delay time, $\overline{\text{EDS}}$ high to data bus enable (read cycle)	$1.25t_c-40$	
$t_d(\text{EL-DV})$	Delay time, $\overline{\text{EDS}}$ low to read data valid		$t_c-65$ ‡
$t_h(\text{EH-D})\text{R}$	Read data hold time from $\overline{\text{EDS}}$ high	0	
$t_{su}(\text{WT-COH})$	$\overline{\text{WAIT}}$ setup time to CLKOUT high	$0.25t_c+75$ ¶	
$t_h(\text{COH-WT})$	$\overline{\text{WAIT}}$ hold time from CLKOUT	0	
$t_d(\text{EL-WTV})$	Delay time, $\overline{\text{EDS}}$ low to $\overline{\text{WAIT}}$ valid		$0.5t_c-70$
$t_w$	Pulse duration, $\overline{\text{EDS}}$ , $\overline{\text{CSE1}}$ , $\overline{\text{CSE2}}$ , $\overline{\text{CSH1}}$ , $\overline{\text{CSH2}}$ , $\overline{\text{CSH3}}$ , and $\overline{\text{CSPF}}$ low	$t_c-40$ ‡	$t_c+40$ ‡
$t_d(\text{AV-DV})\text{R}$	Delay time, address valid to read data valid		$1.5t_c-75$ ‡
$t_d(\text{AV-WTV})$	Delay time, address valid to $\overline{\text{WAIT}}$ valid		$t_c-85$
$t_d(\text{AV-EH})$	Delay time, address valid to $\overline{\text{EDS}}$ high (end of write)	$1.5t_c-40$ ‡	

†  $t_c$  is defined to be  $2/\text{CLKIN}$  and may be referred to as a machine state or simply a state.

‡ If wait state, PF Wait, or Auto-Wait feature is used, add  $t_c$  to this value for each wait state invoked.

¶ If the Auto-Wait feature is enabled, the  $\overline{\text{WAIT}}$  input may assume a "Don't Care" condition until the third cycle of the access.

The following subsections discuss the more important signal timings that need to be considered when interfacing the TMS370 with external memory. With each system design there are usually trade-offs due to speed and/or budget constraints. The timings given here reflect worst case specifications and typical values have been avoided where possible.

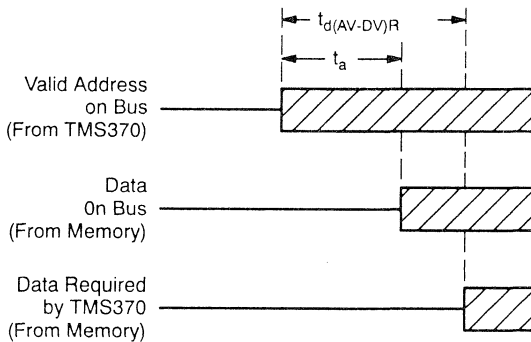
### 14.1.1 Read Cycle Timing

The TMS370 requires a minimum amount of address-to-data access time dependent on the CPU clock speed and the number of wait states used. When interfacing the TMS370 with external memory devices, the following requirements need to be met or incorrect data may be read. These requirements are based on a 20 MHz clock frequency.

#### 14.1.1.1 Valid Address-To-Data-Read-Time Requirement

The valid address to data read time is the basic read cycle requirement that must be met by the external device. This is the period from the instant the TMS370 outputs a valid address until the TMS370 requires data on the data bus pins. This requirement is variable by using wait states to delay the moment the TMS370 reads data.

Figure 14–2. Valid Address-To-Data Read Timing



Name	Description	Formula	Time
$t_d(AV-DV)R$	TMS370 (0 wait) requires data	$1.5t_c-75$	225 ns(too fast)
$t_d(AV-DV)R$	TMS370 (1 wait) requires data	$2.5t_c-75$	425 ns(ok)
$t_d(AV-DV)R$	TMS370 (PF wait) requires data	$3.5t_c-75$	625 ns(ok)
$t_a(A)$	TMS27C256-45 provides data		450 ns(too slow)
$t_a(A)$	TMS27C256-30 provides data		300 ns(ok)
$t_{AA}$	HM6264-15 provides data		150 ns(ok)

As indicated above, the EPROM (TMS27C256) cannot provide the the data quickly enough when the TMS370 device runs at full speed (zero wait states.) Therefore, the TMS370 device should use the Auto-Wait feature (SCC1.4) to add a wait state (one clock cycle) to the timing in order to slow the bus accesses. The wait state extends the access time (data required by TMS370) until 425 ns, and by that time the EPROM is ready with the data. The Auto-Wait feature allows the TMS370 to be used in low-cost applica-

tions where cheaper, slower memory devices are used. The HM6264-15 RAM can exceed the TMS370's minimum address-to-data setup time with no wait states. The Auto-Wait feature may be turned off when accessing external RAM comparable to the Hitachi device to speed system throughput.

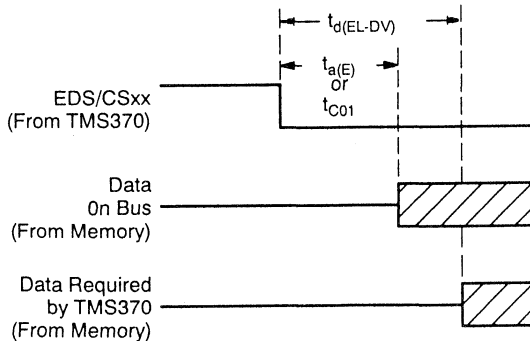
A peripheral device may have up to 625 ns to respond to the TMS370 if the Peripheral Wait states are enabled. If the extra wait states are not needed, the TMS370 treats the peripheral device like other memory.

**14.1.1.2 Chip Select Low To Data Read Requirements**

This parameter states the amount of delay from the time the chip select signal goes low to the time the TMS370 expects valid data on the bus. The chip select ( $\overline{CSxx}$  or  $\overline{EDS}$ ) signal(s) must be used with external memory to validate the memory cycle. Connecting the Chip Select ( $CSxx$ ) pin of the TMS370 to the EPROM's enable ( $\overline{E}$ ) pin allows the EPROM to enter the low power standby mode when not providing data. This significantly lowers the power requirements for the system because only one EPROM operates in the full-power operating mode at any one time. The HM6264 also enters a low-power standby mode whenever the  $\overline{CS1}$  pin is pulled high.

Name	Description	Formula	Time
$t_d(EL-DV)$	TMS370 (0 wait) requires data	$t_c-65$	135 ns(too fast)
$t_d(EL-DV)$	TMS370 (1 wait) requires data	$2t_c-65$	335 ns(ok)
$t_d(EL-DV)$	TMS370 (pf wait) requires data	$3t_c-65$	535 ns(ok)
$t_a(E)$	TMS27C256-30 provides data		300 ns(ok)
$t_{C01}$	HM6264-15 provides data		150 ns(ok)

Figure 14-3. Chip Select Low To Data Read Timing



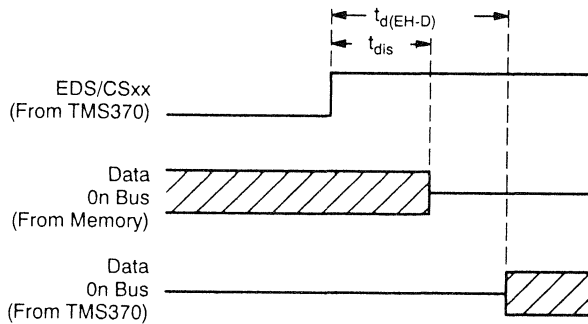
14.1.1.3 Chip Select High To Next Data Bus Drive Requirements

14

The TMS370 and the memory device should not drive the bus at the same time. This can lead to increased stress and noise spiking on the  $V_{CC}$  and  $V_{SS}$  lines, and reduce the reliability of the device. Memory devices often continue to drive the bus for a short time after the chip select signal goes high. This normally doesn't present a problem unless the chip select signal is delayed by interface circuitry and the data is not. If the chip select high transition is delayed long enough (and the data is not), the TMS370 will initiate a write cycle while the memory is still providing data.

Name	Description	Formula	Time
$t_d(\text{EH-D})$	TMS370 (all) drives bus	$1.25t_c - 40$	210 ns
$t_{dis}$	TMS27C256-45 releases bus		130 ns
$t_{dis}$	TMS27C256-30 releases bus		105 ns
$t_{OHZ}$	HM6264-15 releases bus		50 ns

Figure 14-4. Chip Select High To Next Data Bus Drive Timing



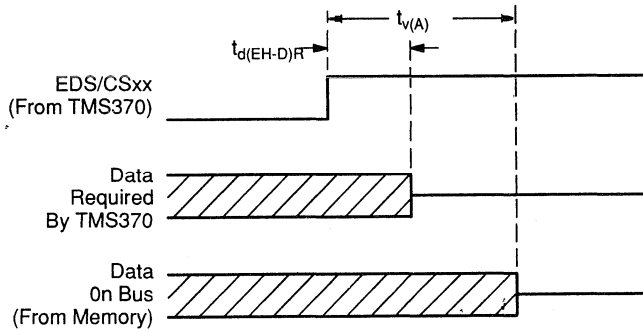


**14.1.1.4 Read Data Hold After Chip Select High Requirements**

The high transition of the chip select signal ( $\overline{CHxx}$ ) indicates the end of a data transfer (in this case, a read) cycle. The memory device must provide data up to this point or incorrect data may be read. Most memories will continue to hold (or drive) the data bus for a short time after they are deselected, although the data may or may not be valid. After that period, the memories put their data outputs into the high-impedence state.

Name	Description	Formula	Time
$t_{d(EH-D)R}$	TMS370 (all) needs data	-	0 ns
$t_{v(A)}$	TMS27C256-30 data	-	0 ns
$t_{HZ1}$	HM6264-15 holds data	-	0 ns

**Figure 14-5. Read Data Hold After Chip Select High Timing**



14

### 14.1.2 Write Cycle Timing

The write cycle timing is defined primarily by the characteristics of the RAM interfacing with the TMS370. The Hitachi HM6264 used in this example offers two types of write cycles and this application uses a write cycle where the output enable ( $\overline{OE}$ ) pin is always fixed low. With the CS2 pin tied to  $V_{CC}$ , the  $\overline{CS1}$  and R/W signals determine the read and write cycle boundaries. A separate address decoder may be used instead of the chip select functions, but the  $\overline{EDS}$  must be used to validate the memory cycle. The  $\overline{EDS}$  signal has the same timing as the chip select signals. Figure 14–6 shows the write cycle parameters that need to be met and are discussed in the following paragraphs.

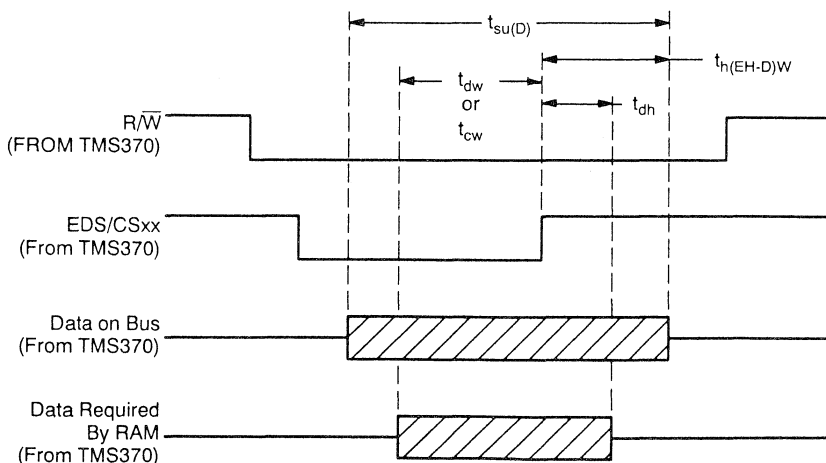
Name	Description	Formula	Time
$t_w$	TMS370 (no wait) pulse width provided	$t_C-40$	160 ns
$t_w$	TMS370 (pf wait) pulse width provided	$3t_C-40$	560 ns
$t_{cw}$	HM6264-15 pulse width required		100 ns

#### 14.1.2.1 Write Data Setup Time Requirements

The write data setup time is the period the RAM needs to receive data before the chip select signal goes high (inactive).

Name	Description	Formula	Time
$t_{su}(D)$	TMS370 (no wait) provides data	$0.75t_C-40$	110 ns
$t_{su}(D)$	TMS370 (pf wait) provides data	$2.75t_C-40$	510 ns
$t_{dw}$	HM6264-15 requires data		60 ns

Figure 14–6. Write Data Setup Timing



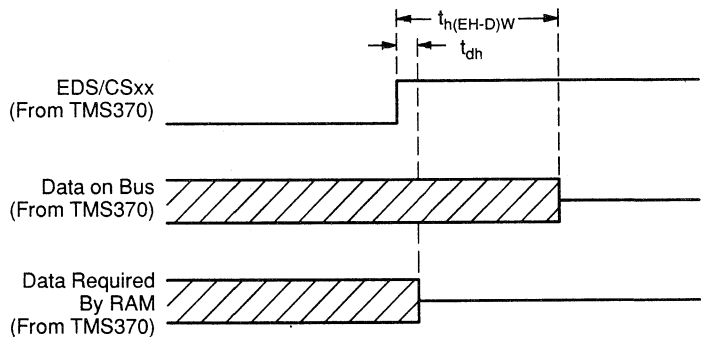
In the interface example the TMS370 satisfies the HM6264-15 RAM's setup requirement, even with no wait state. In a system design where bus transceivers have been added, however, setup timing becomes more important.

### 14.1.2.2 Data Hold After Chip Select High

The TMS370 must hold valid data on the bus until the RAM no longer needs it, otherwise, incorrect data may be written into the RAM. Most RAMs do not need data present on the pins following the chip select's high transition. The TMS370 generally holds data much longer than required by most RAMs.

Name	Description	Formula	Time
$t_{h(EH-D)W}$	TMS370 (all) provides data	$0.75t_c + 15$	165 ns
$t_{DH}$	HM6264-15 requires data		0 ns

Figure 14-7. Write Data Hold After Chip Select High



### 14.1.3 Design Options

The interface example illustrated in Figure 14-1 shows a compromise of system speed and cost. As with all projects, a priority of design goals must be established. Below are some suggestions for optimizing a system toward these goals.

#### 14.1.3.1 Lower Cost

If system cost becomes more important, slower memories that are less expensive should be used. The slowest TMS27C256-45 EPROM has an access time of 450 ns. However, even with one wait state, the TMS370 needs data before this EPROM can supply it. A 19 MHz or lower crystal oscillator solves the problem by extending the clock cycle time. The EPROM's  $\bar{E}$  pin

can no longer be used as enable strobe because of the slower response time. The system must use the EPROM's  $\overline{G}$  pin which provides sufficient time.

A designer still desiring the low power standby mode needs to connect the  $\overline{E}$  pins of all of the EPROM's to one or more general purpose I/O pins on the TMS370. Software can then turn off the EPROMs when not in use. Since the RAMs have no trouble meeting the requirements of a 20 MHz clock, a slower crystal speed presents no problem.

A. Access time from address to valid data (@ 19 MHz,  $t_c=210.5$ )

TMS370 (1 wait) requires data	$t_{D(AV-DV)R}$	$2.5t_c-75$	451 ns
TMS27C256-45 provide data	$t_A(A)$		450 ns (ok)

B. Access time from enable low to valid data (@ 19 MHz,  $t_c=210.5$ )

TMS370 (1 wait) requires	$t_{d(EL-DV)}$	$2t_c-65$	335 ns
TMS27C256-45 provides data	$t_A(\overline{E})$	$\overline{E}$ pin	450 ns(not ok)
TMS27C256-45 provides data	$t_{EN}(\overline{G})$	$\overline{G}$ pin	135 ns(ok)

### 14.1.3.2 Faster Speed

If the main objective is system speed, then the slowest EPROM that will work with the TMS370 running without wait states should be used. The TMS370 at 20 MHz has a read access time requirement of 225 ns, therefore the TMS27C256-20 EPROM which provides data in 200 ns should be used. As with the low cost suggestions above, the EPROM's  $\overline{E}$  pin is not fast enough to use the chip select strobe. The EPROM's  $\overline{G}$  pin should be used instead. To get a low power standby mode with the EPROMs, use general purpose output lines from the TMS370 to the EPROM's  $\overline{E}$  pin. The pins should be software enabled before entering the EPROM's program.

A. Access time from address to valid data:

TMS370 (no wait) requires data	$t_{D(AV-DV)R}$	$1.5t_c-75$	225 ns
TMS27C256-20 provide data	$t_A(A)$		200 ns (ok)

B. Access time from enable low to valid data:

TMS370 (no wait) requires	$t_{D(EL-DV)}$	$t_c-65$	135 ns
TMS27C256-20 provides data	$t_A(\overline{E})$	$\overline{E}$ pin	200 ns (not ok)
TMS27C256-20 provides data	$t_{EN}(\overline{G})$	$\overline{G}$ pin	75 ns (ok)

### 14.1.4 Software Examples For Bank Switching

The following programs show how memory bank switching can be used by the circuit in Figure 14–1. Memory bank switching allows two or more memory devices to share the same addresses. The programmable chip select ( $\overline{\text{CSHx}}$ ,  $\overline{\text{CSEx}}$ , and  $\overline{\text{CSPF}}$ ) signals are used to enable the memory devices or "banks" one at a time during a read or write cycle.

In the interface example, the three EPROM devices share addresses 8000h through FFFFh. Only one EPROM device (or bank), selected by either  $\overline{\text{CSH1}}$ ,  $\overline{\text{CSH2}}$ , or  $\overline{\text{CSH3}}$ , will be reading data at any one time. The two RAM devices are each mapped at addresses 2000h through 3FFFh. The write and read cycles involve one RAM device at a time as determined by the  $\overline{\text{CSE1}}$  and  $\overline{\text{CSE2}}$  signals. The  $\overline{\text{CSPF}}$  signal controls the peripheral memory device which in our example is unspecified but defined to contain 64 bytes of memory. This device is mapped at addresses 10C0h through 10FFh.

To use external memory, devices with bus expansion must be configured for the microcomputer mode so that the chip select signals are available for use. The external memory devices must have 3-state outputs, since these devices share the data bus.

#### 14.1.4.1 Initialize to EPROM/RAM Bank 1

The following program initializes the ports to use bank 1 of the EPROM and the RAM as used in Figure 14–1. The TMS370 must be in the microcomputer mode since the chip selects are not available in the microprocessor mode. After an external reset the TMS370 executes from the internal memory.

```

PORTI  OR    #020h,P010      ;Enable Peripheral file
      AND    #0EFh,P011     ;auto-wait cycles
      ;Enable General memory wait
      ;cycles (default condition
      ;after reset)
      MOV    #0FFh,P021     ;Set Port A up as a Data Bus
      MOV    #0FFh,P025     ;Set Port B up as the Low
      ;Address bus
      MOV    #07Fh,P029     ;Set Port C 0–6 up as the High
      MOV    #000h,P02B     ;address bus
      ;C7 is not needed for address
      ;so make it a
      ;general purpose input.
      MOV    #000h,P02C     ;
      MOV    #0E7h,P02E     ;Set all CSxx to 1 when CSxx
      ;are outputs
      MOV    #0D0h,P02D     ;Enable CSH1, CSE1, and
      ;R/W functions.
      MOV    #0E7h,P02F     ;Turn all Chip Selects to outputs.
      ;Pull-ups resistors are important
      ;for power-up since CSxx are high
      ;impedance floating inputs.

```

#### 14.1.4.2 Changing to EPROM Bank 2

The following program illustrates how to change the EPROM bank while leaving the RAM banks unaffected. In this example, the program runs out of internal memory and disables all EPROM banks and then enables EPROM bank 2 for use. For this reason, the program must not reside in an EPROM. The program could test various EPROM bank 2 memory locations before executing the branch instruction in order to verify that EPROM bank 2 exists within the system.

```
AND    #0B9h,P02D    ;Disable all EPROM banks (cannot
                    ;be done while executing from EPROM banks.)
OR     #004h,P02D    ;Enable EPROM bank 2. When turned off,
                    ;pin outputs a 1 because of the
BR     ROM2          ;initial setup above, could be done
                    ;in 1 instruction if conditions of
                    ;other chip selects was known.
```

#### 14.1.4.3 Change To EPROM Bank 3 and RAM Bank 2

This routine provides switching from one EPROM bank to another while operating from an EPROM bank. Only one instruction (in EPROM bank 2) is needed. The code within the EPROM banks must be synchronized, and the instruction at the address after the move instruction must be a valid instruction within the new EPROM bank.

```
GOROM3 MOV #003h,P02D ;Enable ROM bank 3 and RAM bank 2.
ROM3    ;This address must be the same
        ;as the beginning routine address
        ;in bank 3 if executing from EPROM.
```

#### 14.1.4.4 Change RAM Banks

This method shows how to change RAM banks without affecting the execution out of the current EPROM bank. The RAM banks are selected and deselected the same as EPROM banks. When changing RAM or EPROM banks, the software must insure that only one bank is selected at any one time. This example disables the  $\overline{\text{CSE1}}$  and  $\overline{\text{CSE2}}$  signals and enables the  $\overline{\text{CSE2}}$  signal.

```
AND    #07Eh,P02D    ;Turn off all RAM banks (execute
                    ;from EPROM or on chip)
OR     #001h,P02D    ;Turn on RAM bank 2. When turned off,
                    ;pin outputs a 1 because of the
                    ;initial set-up above.
```

## 14.2 Programming with the TMS370 Family

14

The following example demonstrates the self-programming ability of the TMS370 family. This feature can be used to program any byte of the on-board data and program EEPROM by passing the appropriate data and address to this routine.

This program consists of 3 major sections: the procedure that loads the core program into RAM (RAMJAM), the procedure that determines the bits that need to be changed (PROGRAM), and the procedure that changes these bits (RAMPROG).

RAMJAM is a routine that moves the 19 byte core programming routine into RAM starting at address 20h in the Register area. It only needs to run once during the initialization portion of the program.

PROGRAM attempts to save programming time by checking which portions of the 2 step programming procedure have to occur. If the data already in the array is the same as the new wanted data then no programming need occur. If the program can omit a write ones or a write zeros operation then 10 ms is removed from the total 20 ms programming time. Every programming step that this routine omits saves 10 ms.

RAMPROG is the RAM resident routine which initiates, times and then stops the actual EEPROM programming. During this section of code the interrupts should be disabled to avoid having to use the program memory. All program memory is disabled while programming the program EEPROM so neither a routine execution or interrupt vector access can occur during the program cycle. RAMPROG resides in RAM because it needs to program both data and program EEPROM for this general purpose example.

All read and write accesses to each EEPROM array are disabled while any one byte in that array is being programmed. This means that a program cannot execute out of program EEPROM while programming it. Likewise the program cannot execute out of data EEPROM if it is being programmed. Another place to locate the core routine which does the actual programming is in the RAM. This general purpose core program takes only 19 bytes of RAM and can program both the data and program EEPROM arrays. This core routine could reside in program memory if only data EEPROM needed programming and vice versa.

Unprotected data EEPROM may be programmed using only the  $V_{CC}$  power supply. Enter the WPO mode by placing 12 V on the MC pin when programming program EEPROM or protected data EEPROM.

The program EEPROM array cannot be used while it is programming so the actual program code must reside in other memory, the most general being



RAM. This section resides in the initialization routine and loads the code to program EEPROM into the RAM. (if only data EEPROM needs programming the RAMPROG code can reside in regular ROM and the RAMJAM section can be removed.)

```

TEMP1      .EQU R3                ;general purpose 16 bit
                                         ;register
ETYPE      .EQU R7                ;EEPROM array type 0= data,
                                         ;2=program
EECTL      .EQU 101Ah             ;index address for EEPROM
                                         ;control register
EEPROG     .EQU 20h               ;location of the entry point of
                                         ; the programming routine
RAMJAM     MOV  RAMJAM-RET+1,B      ;Transfer all bytes.
FILLRAM    MOV  RAMPROG-1(B),A     ;Move small program from ROM
                                         ;into RAM starting at 20h
                                         ;
                                         ;
                                         ;Goto more initialization
                                         ;program

```

The processor must be in internal memory for correct operation of program EEPROM during this core routine. This section will be referenced as EEPROG once moved.

```

                                         ;A= EECTL value
                                         ;'xx/blk/' ones/execute
                                         ;ETYPE = EEPROM array type 0=Data
                                         ;2=Program
                                         ;Routine's real address is 20h,
                                         ;EEPROG=20h
RAMPROG    MOV  A,@ADDR1           ;move data to address
           MOV  ECOM,A
           MOV  A,EECTL(B)        ;Load proper EECTL register
                                         ;Wait 10 ms for EEPROM write
WAIT10     MOVW #2778,TEMP1
           INCW #-1,TEMP1         ;11cy: (18 cycles *.2 us/cycle)
                                         ; * 2778 = 10 ms
           JC   WAIT10           ;7cy: ( at 20MHz)
           CLR  A                 ;stop programming pulse
           MOV  A,EECTL(B)        ;clear out EECTL
RET        RTS                    ;exit from internal Ram program
                                         ;19 bytes total

```

The following program is used to write to any location in the data or program EEPROM. Program memory can only be modified when executing outside of program memory.

Parameters used: ADDR1 = EEPROM address;  
 A = data to write to EEPROM array  
 ETYPE = 0 = DATA EEPROM;  
 2 = PROGRAM EEPROM  
 ETYPE set before entering this routine

```

TEMP2   .EQU   R4           ;general purpose temporary
                                ;register
ADDR1   .EQU   R6           ;contains address for
                                ;program operations
EEPROM  .EQU   20h         ;starting address of RAM
                                ;code which programs eeprom.
PROGRAM PUSH   B           ;save value in B
CLR     B           ;initialize eeprom type to
                                ;Data EEPROM
CMP     #01Fh,ADDR1-1      ;Data EEPROM resides at
                                ;1F00h to 1FFFh
                                ;
JEQ     ISSAME           ;Set to Program EEPROM type
MOV     #2,B           ;save data
ISSAME  MOV     A,TEMP2    ;read current data
MOV     @ADDR1,A        ;different bits=1
XOR     TEMP2,A         ;if byte is already equal
JZ      EXITW           ;then exit
                                ;different bits=0
INV     A               ;bits that change from
OR      TEMP2,A         ;1 to 0 = 0
BTJZ   #0FFh,A,WRITE0   ;If any 0s, then must
                                ;program the zero's
JMP     ONES           ;If all 1s, advance to
                                ;program 1s part
WRITE0  DINT          ;No interruptions
MOV     #1,ECOM        ;EECTL value = 1 (program 0s)
MOV     TEMP2,A        ;reload EEPROM data
EEPROM  CALL    EEPROM   ;do the write of only the
                                ;needed 0s
                                ;interrupt can happen now
ONES    MOV     @ADDR1,A ;get the current data
XOR     TEMP2,A        ;bits that change = 1
AND     TEMP2,A        ;bits that change from
                                ;0 to 1 = 1
JZ      LASTCHK        ;are there any 1s to program?
WRITE1  DINT          ;No interruptions
MOV     #3,ECOM        ;EECTL value=3 (program 1s)
MOV     TEMP2,A        ;reload EEPROM data
CALL    EEPROM         ;do the write of only the
                                ;needed 1s
                                ;interrupt can happen now
LASTCHK MOV     @ADDR1,A ;Check new memory against
                                ;wanted memory
                                ;if equal then exit
CMP     TEMP2,A        ;if equal then exit
JEQ     EXITW          ;If the program gets here
CALL    ERROR          ;there has been an error
EXITW  POP     B        ;return value to B register
RTS                                ;back to calling program
    
```

The following example is the same as the PROGRAM routine above but with actual values given for each step. The values shown are the LSB nibble of a byte expressed in binary and chosen because they give all possible bit combinations. In this example the memory address already has x1100 and we want to program x1010 to that address. Before calling the EEPROG routine, the program writes new data to the EEPROM address located in register ADDRESS and then passes data in register A which specifies either a write ones or a write zeros operation.

```

                                A      @ADDRESS
PROGRAM  PUSH      B              ; x1010      x1100      Data EEPROM type
        CLR      B              ;
        CMP      #01Fh, ADDR1-1 ;
        JEQ      ISSAME         ;
        MOV      #2, B          ;
ISSAME   MOV      A, TEMP2       ;
        MOV      @ADDR1, A      ; x1100      read current data
        XOR      TEMP2, A       ; x0110      different bits = 1
        JZ      EXITW          ;
        INV      A              ; x1001      if A =0 data the same
        OR      TEMP2, A        ; x1011      different bits = 0
        BTJZ    #FF, A, WRITE0 ;
        ;                      ;
        JMP      ONES          ;
WRITE0   DINT     ONES           ;
        MOV      #1, ECOM       ; x1100      check write1's
        MOV      TEMP2, A       ;          disable interrupt
        CALL    EEPROG         ;          program to write0's
EEPROM   CALL    EEPROG         ;          reload EEPROM data
        EINT     ;              ;          do write0's
ONES     MOV      @ADDR1, A     ; x1000      enable interrupts
        XOR      TEMP2, A       ; x0010      read new current data
        AND      TEMP2, A       ; x0010      bits that change = 1
        JZ      LASTCHK       ;          1 is bit to change to 1
WRITE1   DINT     ;              ;
        MOV      #3, ECOM       ;          disable interrupts
        MOV      TEMP2, A       ;          program to writel's
        CALL    EEPROG         ;          reload EEPROM data
        EINT     ;              ;          do writel's
LASTCHK  MOV      @ADDR1, A     ; x1010      enable interrupts
        CMP      TEMP2, A       ;          read new current data
        JEQ      EXITW         ;          compare to data wanted
        CALL    ERROR          ;          the same then return
        ;                      ;          ;If the program gets here there has been an
EXITW    POP      B              ;error
        RTS     ;              ;return value to B register
        ;                      ;

```

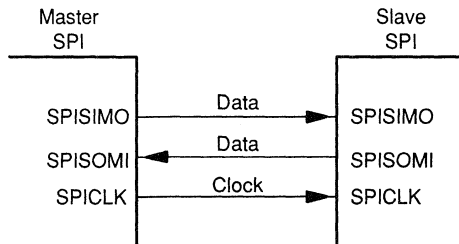
## 14.3 Serial Communications

All devices in the TMS370 family provide serial communication capability with peripheral devices. The TMS370Cx1x series provides one serial (SPI) port providing communication capability with peripheral devices. The TMS370Cx3x series provides one serial port that is part of the PACT module (PACT-SCI, see Section 14.5.3). The TMS370Cx5x series provides two serial (SPI and SCI) ports for enhanced communications capability with peripheral devices.

### 14.3.1 SPI Port Interfacing

The SPI port provides synchronous communication with peripherals such as shift registers, display drivers, A/D converters, and other microcomputers. Synchronous transmission is supported by programmable parameters such as character length (one to eight bits) and bit transfer rate (eight options). In the example below, the SPI port is configured as a Master/Slave dual microcomputer interface. This full-duplex setup has the master microcomputer initiating data transfer by sending the SPICLK signal to the slave. Data is then transmitted between the microcomputer simultaneously until the clock signal stops. Either or both of the data lines may send valid or dummy data, depending on the software.

**Figure 14–8. Master/Slave SPI Interface Example**



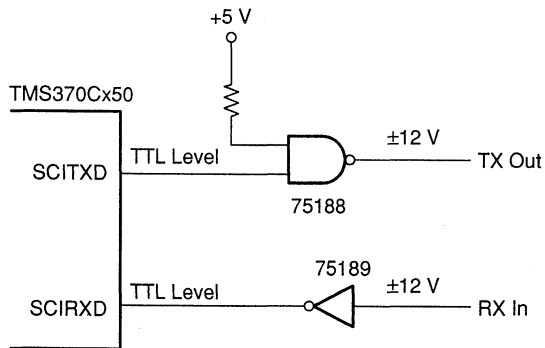
### 14.3.2 SCI Port Interfacing

The SCI port (TMS370Cx5x only) provides communication with peripheral devices in either an Asynchronous or Isosynchronous format. This makes it especially suited for communicating with a variety of devices. The format parameters of the SCI are software programmable and are as follows:

<u>Parameter</u>	<u>Options</u>
Mode	Asynchronous, Isosynchronous
Baud rate	64 K possibilities
Character length	1 to 8 bits
Parity	Even, Odd, Off
No. of stop bits	1 or 2
Interrupt priorities	Receiver/transmitter

The SCI port is configured for a RS-232-C type interface in the figure below. Since the TMS370 family uses TTL-level I/O, the transmit and receive data signals must be converted to RS-232 levels. The 75188 and 75189 devices provide this function. In the asynchronous format, the clock signal does not need to be transmitted, but is generated locally at both ends.

**Figure 14–9. SCI/RS–232 Interface Example**

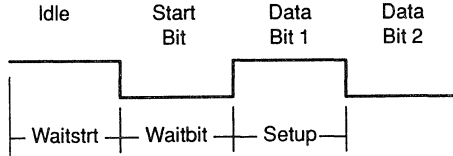


The following routine automatically calculates the baud rate for the SCI port by timing the length of the start bit. Many times this eliminates the need for external select switches which can cause confusion.

This routine converts the SCIRXD pin to a general purpose input pin and then samples this pin until it finds the start bit. Sampling is controlled by the baud rate counter, which takes 32 cycles for one complete count. At each count, or every 32 cycles, the input pin is sampled. When the start bit is received, its low state is sampled until the high state of the first data bit (of an

odd ASCII value) is detected. The number of times the start bit is sampled is used by the baud rate registers to figure the baud rate.

**14** Figure 14–10. Auto Baud Rate Waveform



```

0050          SCICCR .EQU P050          ;SCI communication control register
0051          SCICTL .EQU P051          ;SCI control register
0052          BAUDMSB .EQU P052         ;baud rate counter MSB
0053          BAUDLSB .EQU P053         ;baud rate counter LSB
0054          TXCTL .EQU P054           ;Transmitter control
0055          RXCTL .EQU P055           ;Receiver control
0057          RXBUF .EQU P057           ;Receiver buffer
0057          TXBUF .EQU P059           ;Transmitter buffer
005D          SCIPC1 .EQU P05D          ;Port control 1 (SCLK)
005E          SCIPC2 .EQU P05E         ;Port control 2 (TXD,RXD)
005E          SCIPRI .EQU P05F         ;priority register
005E          COUNT .EQU R04           ;temporary counting register
0000
0000          .TEXT 07000h              ;INITIALIZE SCI PORT WITH
0000          ;A CR (RETURN)
7000          AUTOBAUD                  ;Baud automatically
7000          ;set on Odd ASCII
7000          ;character
7000          CLR COUNT                  ;clear count register
7002          CLR COUNT-1                ;COUNT-1
7004          F7005E                     MOV #0,SCIPC2
7007          ;set RxD to general
7007          A6085EFC WAITSTRT          BTJO #8,SCIPC2,WAITSTRT
700B          ;wait for
700B          ;a start bit to go low
700B          B3                          WAITBIT   INC A
700C          ;dummy, gives 32
700C          ;clock states
700C          ;(1 min baud)
700C          ;increment counter
700C          700104                     INCW #1,COUNT
700F          A7085EF8                    BTJZ #8,SCIPC2,WAITBIT
7013          ;wait until start bit
7013          70FF04                     SETUP     INCW #-1,COUNT
7016          ;ends (ASCII char=odd)
7016          ;one less than count
7016          ;into baud reg
7019          MOV COUNT,BAUDLSB          ;since the SCI starts
7019          ;from count 0.
7019          MOV COUNT-1,BAUDMSB       ;initialize baud rate
701C          ;registers.
701C          F7225E                     MOV #22h,SCIPC2
701F          F7025D                     MOV #2,SCIPC1
7022          F77750                     MOV #01110111b,SCICCR
7025          ;8-bits length, even parity,
7025          ;1 stop ;bit
7025          ;only even, odd, or none parity
7027          ;determined
7027          ;by SCICCR value
7025          F73351                     MOV #00110011b,SCICTL
702C          ;enable Tx, Rx, SCLK = internal
702C          ;program after input character
7028          ;finishes)
7028          F70154                     MOV #1,TXCTL
702B          F70155                     MOV #1,RXCTL
702E          8057                       MOV RXBUF,A
7032          ;enable TX interrupts
7032          ;enable RX interrupts
7032          ;clear out garbage from SCI (Place in
7032          ;program after input character finishes)
7032          F00C                       EINT

```

---

This routine can be improved to give greater flexibility and accuracy using some of the following suggestions:

- 1) Time more than one bit and then divide by the number of bits to give a greater accuracy. This means that a more carefully chosen character must be used to start the autobaud routine. The current routine can use 50 per cent of the ASCII values (all odd ASCII values).
- 2) Add a routine to check the parity of the incoming character and set the parity of the SCI port accordingly. Again, this means a limited number of characters will correctly autobaud the routine.
- 3) Add routines to compare the count of another bit in the character to the start bit count as an accuracy check. This gives the same problems as before.

For a more in-depth discussion of the uses of the TMS370 SCI, consult *Using the TMS370 SPI and SCI Modules Application Report*, literature number SPNA006.

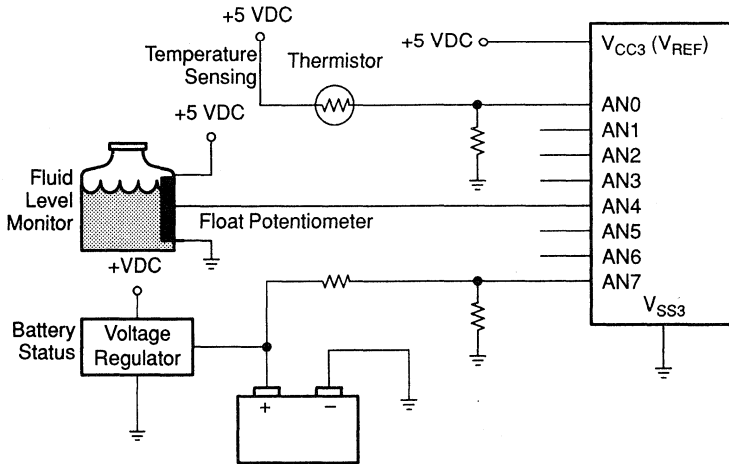
14

### 14.4 Analog/Digital Converter

The A/D converter provides built-in data acquisition capability with 8-bit resolution. Any or all of the A/D pins may be used as a single-ended input with reference to analog ground ( $V_{SS3}$ ). Pins not used for A/D conversion may be software configured as a standard digital input pins. The high reference voltage ( $V_{REF}$ ) may be either  $V_{CC3}$  or supplied by one of the inputs. If the sampled input is higher than  $V_{REF}$ , the conversion value placed in the A/D data register is FFh, indicating full scale. If the sampled input is lower than  $V_{SS3}$ , then the value 00h is placed in the A/D data register.

A variety of functions may be performed by the CPU using the A/D converter. Industrial applications may include temperature sensing, fluid level monitoring, and recharging circuit status as indicated in the figure below. If the sending units are designed for greater than  $V_{REF}$ , a resistance network may be needed to keep the A/D input voltage within the meaningful range of  $V_{REF}$  to ground. This is especially true in the case of a fluid level sensor, where the full linear range may be required.

**Figure 14–11. A/D Converter Sample Applications**





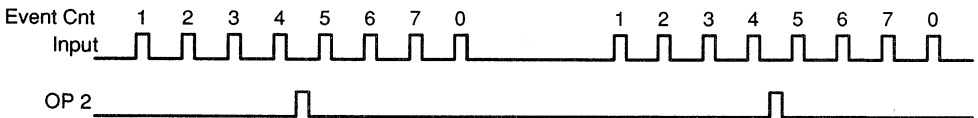
## 14.5 PACT Module

The following section contains sample routines that show some of the various capabilities of the PACT module. An additional example of using the PACT module to produce a PWM signal is discussed in Section 12.9. All of these routines use a macro header file (PACT.H) to facilitate the setup of the PACT command/definition area. This header file is discussed in Appendix G.

### 14.5.1 Time After Event Example

The offset timer definition and the conditional compare command are used to create an output signal that is delayed in time from an input signal. For example, we have an input signal that consists of a series of eight short pulses 100 microseconds apart. These pulses repeat after an unspecified time period. We want to create an output pulse of ten microseconds duration centered between the fourth and fifth pulse of the series. This is shown in Figure 14–12 below.

**Figure 14–12. Time After Event – Example Waveforms**



The input signal is connected to CP6 of the PACT module so that it will increment the event counter. Output pins 1–7 could be used for the output signal. In this example we have chosen to use OP2.

The routine to accomplish this task consists of four parts:

- 1) Defining the PACT command/definition area
- 2) Disabling any currently enabled capture pins
- 3) Transferring the new command/definition area into dual port RAM
- 4) Initializing the PACT peripheral frame

#### 14.5.1.1 Defining the PACT Command/Definition Area

To establish a time base synchronized to the event counter we use the offset timer definition. Since the PACT command/definition area can not start with a definition, a dummy standard command is used as the first entry.

Line 14 of the example routine is the offset timer definition. The maximum event count is set to seven, allowing the event counter to increment from zero through seven (8 counts).

Line 15 creates the conditional compare command that causes the output pin to go high. This command waits for the fourth rising edge on the input pin and then delays another 50 microseconds before setting the pin high. The macro file automatically subtracts two from the supplied number to create the value encoded in the command.

Line 16 creates the conditional compare command that causes the output pin to go low. This happens 60 microseconds after the fourth rising edge on the input pin. A problem can occur if the fifth input pulse occurs less than 60 microseconds after the fourth pulse. Since the conditional compare command would not see the event count set to four and the offset time value equal to 60, the pin would never be cleared. By enabling the `evt_plus1` action of this command we can avoid this problem. The output pin will now be cleared 60 microseconds after the fourth event, or immediately after the fifth event, whichever comes first.

The actual time that the output pin toggles is determined by three different delays: the specified delay, a synchronization delay, and a propagation delay. The specified delay is the value that we use in defining the conditional compare command. It is specified in PACT prescaled clock time periods. It can be no less than two of these periods. The synchronization delay is one prescaled clock time period. Since the output must occur on a prescaled clock boundary but the input edge can occur at any time, one prescaled clock period of jitter results. The propagation delay is three system clock periods (SYSCLK) plus an asynchronous delay of approximately 80 nanoseconds.

For a device operating with a 20 MHz crystal, using a PACT prescale value of 5, with a conditional command delay of two the delay from the input edge on pin CP6 to the output pin edge is:

$$\begin{aligned}
 \text{DELAY} &= 2.5 \times \text{PS} + 3 \times \text{SYSCLK} + 80 \text{ nsec} \pm 1/2 \text{ PS} \\
 &= 2.5 + 0.6 + 0.08 \pm 0.5 = 3.18 \pm 0.5 \mu\text{sec} \\
 \text{PS} &= \text{PACT prescaled clock period} \\
 \text{SYSCLK} &= \text{System clock period}
 \end{aligned}$$

### **14.5.1.2 Disabling Currently Enabled Capture Pins**

When loading new information into the command/definition area it is very important that the PACT module be disabled. A half modified command or definition could cause the PACT module to corrupt other parts of the dual port RAM. To ensure that captures into the old circular buffer do not corrupt your new commands, disable all captures as well. The command/definition area is disabled by line 21 of the example. Lines 22–24 disable all captures from the six input pins. This part of the code is not necessary if the PACT module is being setup immediately after reset.

### **14.5.1.3 Transferring the New Commands and Definitions into Dual Port RAM**

Lines 27 through 32 of this routine copy the new commands and definitions into the dual port memory. These instructions flip the table created by the macros end for end. This makes the table much easier to read since the first command listed will be the first one executed by the PACT module.

### 14.5.1.4 Initializing the PACT Peripheral Frame

Lines 35 through 40 initialize the peripheral frame. Mode A, the default mode, is being used. Initializing the command start address to location 0EBh allows for two 32-bit entries in the circular buffer. Lines 37 and 38 clear the event counter and set the event prescaler to no prescale. The rising edge of CP6 is enabled to perform captures to the circular buffer and increment the event counter. In a real application it would be necessary to ensure that the event counter was not initialized in the middle of a series of eight input pulses. Finally, in line 40, the PACT prescale value is set to five and the command/definition area is enabled.

```

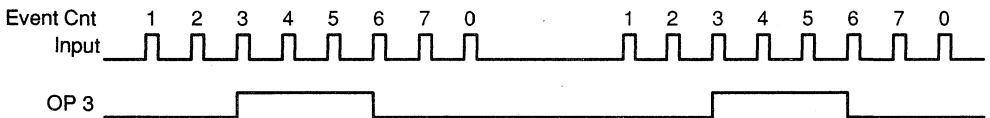
0001 ;This is an example program to do a time after event function
0002 ;
0003 ;MACRO DEFINITIONS
0004 ; STDCMP <compare value>,<pin>,<actions>
0005 ; OFSTMR <max event count>,<actions>,<initial value>
0006 ; CONCMP <evt cmp value>,<time cmp value>,<output pin>,<actions>
0007 ;
0008     .include "pact.h"
0009 cmd_st.equ    0ebh
0010
0011 ;PACT commands
0012     .data 7800h
0013 table stdcmp  00,00,nxt_def           ;next line is definition
0001 #     .byte  0,0,1,0
0014     ofstmr    7,enable
0001 #     .byte  1,0,4,7
0015     concmp   4,50,op2,set_pin
0001 #     .byte  50,0,164,4
0016     concmp   4,60,op2,clr_pin|evt_plus1
0001 #     .byte  60,0,196,4
0017 len     .equ    $-table
0018     .text 6000h
0019 start mov     #3,p04f                 ;disable the watchdog
0020 ;make sure that all captures are disabled
0021     mov     #0,p040                 ;disable cmd/def area
0022     mov     #0,p04a                 ;disable all capture pins
0023     mov     #0,p04b
0024     mov     #0,p04c
0025
0026 ;copy PACT cmds/defs into ram
0027     mov     #len,b
0028     movw   #(cmd_st-len+1),r3
0029 loop  mov     table-1(b),a
0030     mov     a,@r3
0031     inc     r3
0032     djnz   b,loop
0033
0034 ;set up the peripheral file
0035     mov     #cmd_st,p041             ;cmd/def. start at 0ebh
0036     mov     #(cmd_st-len+1),p042    ;cmd/def end at 0e0h
0037     mov     #2,p04d                 ;clear the event counter
0038     mov     #0,p04d                 ;set event prescale to no prescale
0039     mov     #20h,p04c               ;select rising edge on cp6
0040     mov     #034h,p040             ;set prescale to 5, 1 usec resolution
0041
0042 ;Signal running without processor intervention
0043     idle
0044     .end

```

## 14.5.2 Double Event Command Example

If an output pin is to be set or cleared after an input event without an additional time delay, the double event command should be used. One single command can both set and clear an output pin based on two different values of the event counter. Figure 14–13 below shows an input signal that consists of repeated series of eight short pulses. This signal is attached to the event counter input pin, CP6. The desired output signal, shown as coming from output pin OP3, goes high on the leading edge of the third pulse and low on the leading edge of the sixth pulse of each series.

**Figure 14–13. Double Event – Example Waveforms**



The routine to accomplish this task consists of four parts:

- 1) Defining the PACT command/definition area
- 2) Disabling any currently enabled capture pins
- 3) Transferring the new command/definition area into dual port RAM
- 4) Initializing the PACT peripheral frame

The last three parts of this routine are exactly the same as in the previous example so they will not be discussed again here.

The PACT command/definition area in this example consists of one command and one definition. Line 10 is the double event command. Since it does not refer to any timer it may be the first entry in the command/definition area. Two event compare values are specified, 3 and 6. OP3 is the specified output pin. The actions chosen are to set the output pin when the event counter reaches 3, the first event compare action, and to do the opposite action, that is clear the output pin, when the event counter reaches six. The actions also specify that the next area in the command/definition area is a definition.

Line 11 of this example routine is an offset timer definition. Its sole purpose is to set the maximum event count value to seven. The event counter will increment from one to seven and then reset to zero on the last edge of the input series.

```

0001 ;This is an example program to do a DOUBLE EVENT function
0002     .include "pact.h"
0003
0004 ;MACRO FORMATS
0005 ; DEVCMP <event value 1>,<event value 2>,<output pin>,<actions>
0006 ; OFSTMR <max event count>,<actions>,<initial value>
0007
0008 ;PACT commands and definitions
0009     .sect      "pact",7800h
0010 table devcmp 3,6,op3,set_evt1|opp_act|enable|nxt_def
0001 #           .byte 3,6,37,11
0011 ofstmr      8,enable
0001 #           .byte 1,0,4,8
0012 len         .equ    $-table
0013             .text 6000h
0014 start mov     #3,p04f           ;disable the watchdog
0015 cmd_st .equ    0ebh
0016         mov     #0,p040         ;disable cmd/def area
0017         mov     #0,p04a         ;disable all input captures
0018         mov     #0,p04b
0019         mov     #0,p04c
0020
0021 ;copy PACT commands/def. into ram
0022     mov     #len,b
0023     movw   #(cmd_st-len+1),r3
0024 loop    mov     table-1(b),a
0025         mov     a,@r3
0026         inc     r3
0027         djnz   b,loop
0028
0029 ;set up the peripheral file
0030     mov     #cmd_st,p041         ;cmd/def start at 0ebh
0031     mov     #(cmd_st-len+1),p042
0032     mov     #04,p04d           ;event only & evt prescale to divide by 1
0033     mov     #034h,p040         ;timer prescale to 5, 1 usec resolution
0034     mov     #2,p04d           ;clear the event counter
0035     mov     #0,p04d           ;set event prescale to no prescale
0036     mov     #20h,p04c         ;select rising edge on cp6
0037
0038 ;PACT running without processor intervention
0039     idle
0040     .end

```

The delay from the edge that increments the event counter until the output pin changes state is given by:

$$\begin{aligned}
 \text{DELAY} &= 1.5 \times \text{PS} + 3 \times \text{SYSCLK} + 80 \text{ nsec} \pm 1/2 \text{ PS} \\
 \text{PS} &= \text{PACT prescaled clock period} \\
 \text{SYSCLK} &= \text{System clock period}
 \end{aligned}$$

In our example using a 20 MHz crystal and a PACT prescale value of 5, that delay would be:

$$\text{DELAY} = 1.5 + 0.6 + 0.08 \pm 0.5 = 2.18 \pm 0.5 \mu\text{sec}$$

### 14.5.3 PACT SCI Example

This example routine is a simple test of the PACT SCI. Its primary purpose is an introduction of how to use the PACT SCI. This example consists of five parts.

- 1) Defining the PACT command/definition area
- 2) Disabling any currently enabled capture pins
- 3) Transferring the new command/definition area into dual port RAM
- 4) Initializing the PACT peripheral frame
- 5) Running the SCI test routine

The second, third and fourth parts are the same as used in the other PACT example routines and are explained fully in Section 14.5.1. They will not be discussed here.

The PACT command/definition area is used to establish the SCI transmit and receive baud rates. The baud rate timer definition is used to define these baud rates. The first entry in the command definition area, line 13, is a dummy standard compare command since this area can not start with a definition. Line 14 of this routine is the actual baud rate timer definition. In this example the transmit and receive rates are initialized to the same value. The maximum timer value is set by the equation found in Section 12.8:

$$\text{Max Timer Value} = \frac{1}{(\text{Baud rate})(4)(\text{PACT resolution})} - 2$$

For our example of 9600 baud with a PACT resolution of 1 microsecond the required value is:

$$\text{Max Timer Value} = \frac{1}{(9600)(4)(10^{-6})} - 2 = 24$$

The actual SCI test is implemented in lines 39 through 48 of this routine. Eight-bit values are sent out on the transmit pin and then input on the receive pin. In this simple example software polling is used to determine when the transmit or receive buffers are ready. More sophisticated routines would use the interrupts for these two buffers. The two idle instructions in lines 47 and 48 are for setting breakpoints in a PACT XDS/22 emulator. If line 47 is reached, the routine completed without an error. If line 48 is reached, an error was detected. The value transmitted will be in register 2 and the value received will be in register 3.

```

0001 ;This is an example program to verify the serial communications interface
0002 ;on the PACT module. The transmit and receive pins are shorted externally
0003 ;for this test. The timer is set up for 9600 baud.
0004
0005 .include "pact.h"
0006 cmd_st .equ 0ebh
0007 rxreg .equ p046
0008 txreg .equ p047
0009 rxrdy .dbit 7,p045
0010 txrdy .dbit 6,p045
0011
0012 .sect "pact",7800h
0013 table stdcmp 00,00,nxt_def ;next line is definition
0001 # .byte 0,0,1,0
0014 brtmr 24,rx|tx
0001 # .byte 0,0,199,0
0015 len .equ $-table
0016 .text 6000h
0017 start mov #3,p04f ;disable the watchdog
0018 mov #0,p040 ;disable cmd/def area
0019 mov #0,p04a ;disable all input captures
0020 mov #0,p04b
0021 mov #0,p04c
0022
0023 ;copy PACT commands and definitions into RAM
0024 mov #len,b
0025 movw #(cmd_st-len+1),r3
0026 loop mov table-1(b),a
0027 mov a,r3
0028 inc r3
0029 djnz b,loop
0030
0031 ;set up the peripheral file
0032 mov #07,p04f ;set to mode B
0033 mov #cmd_st,p041 ;cmd/def start at 0ebh
0034 mov #(cmd_st-len+1),p042
0035 mov #04,p04d ;event only & no event prescale
0036 mov #034h,p040 ;set prescale = 5, 1 usec resolution
0037
0038 ;Send the numbers 0-255 and receive them on the loopback
0039 clr r2
0040 loop1 jbit0 txrdy,loop1 ;wait until transmit buffer is empty
0041 mov r2,txreg
0042 rxwait jbit0 rxrdy,rxwait ;wait until character is received
0043 mov rxreg,r3
0044 cmp r2,r3 ;compare characters
0045 jne error
0046 djnz r2,loop1 ;loop for all 256 characters
0047 idle ;stop here if no errors
0048 error idle ;error condition occurred
0049 .end

```



## 14.6 Sample Routines

The following section contains sample routines that show the various ways the TMS370 handles common software tasks.

### 14.6.1 T1PWM Pin Setup

The following examples start and stop the PWM function with a certain value on the PWM pin. Starting the T1PWM pin with a specific value can be done with one instruction as shown in the examples below. The value of the data out bit will become the initial value of the PWM pin.

```
MOV #60h,P04E      ;Start with PWM pin high
MOV #20h,P04E      ;Start with PWM pin low
```

The examples below show the two instructions needed when changing the T1PWM pin from a PWM pin to a general purpose output pin with a specific value. The first instruction changes the pin to a general purpose output pin with the same value as the current PWM pin. The second instruction changes the pin to a particular value.

```
MOV #50h,P04E      ;Stop with PWM pin high.
MOV #50h,P04E      ;
MOV #10h,P04E      ;Stop with PWM pin low.
MOV #10h,P04E      ;
```

The following examples keep the current value on the pin when starting or stopping the PWM function. Starting the function requires four instructions while stopping the function takes only one.

```
MOV #20h,A          ;Start with PWM pin same as
BTJZ #80h,P04E,SKIP ;current state.
MOV #60h,A          ;
SKIP MOV A,P04E     ;
MOV #10h,P04E      ;Stop with PWM pin same as
                   ;current state.
```

### 14.6.2 Clear RAM

This routine clears all the internal RAM registers. It can be used at the beginning of a program to initialize the first 256 bytes of RAM to a known value.

	<u>Register</u>	<u>Function</u>
	A	Holds the initialization value
	B	Index into the RAM
0000	0001	.TEXT 7000h ;absolute start address
7000 52FE	0002 CLEAR	MOV #254,B ;number of register to clear
	0003	;-2
7002 B5	0004	CLR A ;load the initialization
	0005	;value of zero
7003 AB0001	0006 LOOP	MOV A,1(B) ;clear the location indexed
	0007	;by B+1
7006 CAFB	0008	DJNZ B,LOOP ;loop until all RAM is
	0009	;cleared
7008	0010	;A and B end up as zeros.

## 14.6.3 RAM Self Test

This routine performs a simple alternating 0/1 test on the first 256 bytes of RAM. The RAM is tested by writing a AA,55 pattern to the entire RAM and then checking the RAM for this pattern. The inverted pattern is then written to RAM and rechecked. Finally, the entire RAM is cleared. If an error is found, a bit is set in the flag register. The error flag bit should be cleared before the routine is started.

Register	Before	After No Error	After Error
A	XX	0	?
B	XX	0	?
Rn	XX	0	?
FLAG	XX	0	Bit 0=1

Passing data                   None  
 Registers affected           All  
 Ending data                   All registers = 0  
                                   Bit 0 in FLAG = 1 if error was found

```

0000      0001      .TEXT 7000H      ;absolute start address
000A      0002 FLAG  .EQU R10      ;error register
7000 2255      0003      MOV #55h,A      ;Start RAM fill with 55h
7002 52FD      0004 FILLR  MOV #0FDh,B ;Set RAM start address - 2
7004      0005      ;(don't change register A or B)
7004 AB0002    0006 FILL1  MOV A,2(B) ;fill RAM with aa to 55 pattern
7007 BC      0007      RR A ;change to beginning number
7008 CAFA      0008      DJNZ B,FILL1 ;fill entire RAM with pattern
700A BC      0009      RR A ;change to beginning number
700B 52FD      0010      MOV #0FDh,B ;refresh index
700D AD0002    0011 COMPAR  CMP 2(B),A ;check for errors
7010 06**      0012      JNE ERROR ;exit if values don't match
7012 BC      0013      RR A ;change from 55 to AA to 55
7013 CAF8      0014      DJNZ B,COMPAR ;check the entire RAM
7015 B0      0015      CLRC ;is reg A now 55, AA or 00?
7016 01EA      0016      JN FILLR ;=AA, change to opposite pattern
7018 02**      0017      JZ EXIT ;=00,
701A B5      0018 FILL0  CLR A ;=55,clear the ram now
701B 00E5      0019      JMP FILLR ;repeat the fill and check routine
701D 74010A    0020 ERROR  OR #1,FLAG ;set bit zero in the flag
7020      0021      ;register
7020      0022 EXIT  .EQU $ ;continue program here
  
```

### 14.6.4 ROM Checksum

This routine checks the integrity of a 4 Kbyte ROM by performing a checksum on the entire ROM. All ROM bytes from 7002h to 7FDFh are added together in a 16-bit word. The sum is checked against the value at the beginning of the ROM (7000h, 7001h). If the values don't match, then an error has occurred and a bit is set in a register. The error flag bit should be cleared before the start of the routine. This routine can easily be modified for other ROM sizes.

**Note:**

Addresses 7FE0h through 7FEBh are reserved for TI use only and should not be used in a checksum calculation.

Register	Before	No Error	Error
A	XX	X	X
B	XX	X	X
R2	XX	CHKSUM MSB	CHKSUM MSB
R3	XX	CHKSUM LSB	CHKSUM LSB
R4	XX	70h	70h
R5	XX	01h	01h
R6	XX	FFh	FFh
R7	XX	FFh	FFh
FLAG	XX	Bit 1=0	Bit 1=1

```

0000      0001      .TEXT 7000h      ;absolute start address
000F      0002      FLAG      .EQU R15      ;error status
3039      0003      CHECKSUM  .EQU 12345     ;value to be checked against
7000 3039  0004      .WORD  CHECKSUM      ;put correct checksum into
7002      0005      ;ROM
7002      0006      ;other initialization
7002      0007      ;program here
7002 887FDF05 0008      ROMCHK  MOVW  #7FDFh,R5  ;starting address (end of
7006      0009      ;memory)
7006 880FDD07 0010      MOVW  #0FDDh,R7  ;number of bytes to add + 1
700A 88000003 0011      MOVW  #0,R3      ;reset summing register
700E      0012      ;
700E 9A05      0013      ADDLOP  MOV  @R5,A      ;get ROM byte
7010 480003      0014      ADD  A,R3      ;add to 16-bit sum
7013 790002      0015      ADC  #0,R2      ;add any carry
7016 70FF05      0016      INCW  #-1,R5     ;decrement address
7019 70FF07      0017      INCW  #-1,R7     ;decrement byte counter
701C 03F0      0018      JC   ADDLOP     ;continue until byte count
701E      0019      ;goes past 0
701E      0021      ;
701E 8A7000      0022      MOV  7000h,A    ;compare MSB stored to MSB
7021      0023      ;sum
7021 4D0002      0024      CMP  A,R2      ;
7024 06**      0025      JNE  ERROR     ;set error bit if different
7026 8A7001      0026      MOV  7001h,A    ;compare LSB stored to
7029      0027      ;LSB sum
7029 4D0003      0028      CMP  A,R3      ;
    
```

```

702C 02**      0029      JEQ   EXIT      ;set error bit if different
702E 74020F   0030  ERROR   OR    #2,FLAG ;set bit 1 in the flag
7031          0031      ;register
7031          0032  EXIT      EQU    ;continue program here

```

### 14.6.5 Binary-to-BCD Conversion

This program converts a 16-bit binary word to a packed 6 nibble value.

<u>Register</u>	<u>Before</u>	<u>After</u>
A	XX	BCD MSB
B	XX	BCD
R2	XX	BCD LSB
R3	BINARY MSB	ZERO
R4	BINARY LSB	ZERO
R5	XX	ZERO

```

0000          0001      .TEXT 7000H ;absolute start address
7000 B5       0002  BN2BCD CLR  A ;prepare answer registers
7001 C5       0003      CLR  B ;
7002 D502     0004      CLR  R2 ;
7004 721005   0005      MOV  #16,R5 ;move loop count to register
7007 DF04     0006  LOOP  RLC  R4 ;shift higher binary bit out
7009 DF03     0007      RLC  R3 ;carry contains higher bit
700B 4E0202   0008      DAC  R2,R2 ;double the number then add
700E          0009      ;the binary bit
700E 3E01     0010      DAC  R1,B ;binary bit (a 1 in carry on
7010          0011      ;the 1st time is
7010 1E00     0012      DAC  R0,A ;doubled 16 times).
7012 DA05F2   0013      DJNZ R5,LOOP ;do this 16 times, once for
7015          0014      ;each bit
7015 F9       0015      RTS ;back to calling routine

```

## 14.6.6 BCD-To-Binary Conversion

This routine converts a four digit number to binary. The maximum BCD number is 9999 decimal. Operands originate and are stored in general purpose RAM. The BCD number is composed of the four digits D3, D2, D1, and D0 contained in the bytes DH and DL. The binary number is calculated by dividing the number into powers of ten (Binary =  $D3*1000 + D2*100 + D1*10 + D0*1$ ). Multiplying by 10 is easier if the number is further broken up in other numbers so that  $D2*10 = D2*(8+2) = D2*8+D2*2$ . Likewise, multiplying by 1000 can be calculated by  $D3*(1000) = D3*(1024-24) = D3*(1024-(8+16)) = D3*1024-(D3*8 + D3*16)$ . This may seem complex but it works quickly and uses few bytes.

```

0000          0010      .TEXT 7000h
0002          0011 BH   .EQU R2          ;Binary number MSB
0003          0012 BL   .EQU R3          ;Binary number LSB
0004          0013 DH   .EQU R4          ;Decimal number MSB
0005          0014 DL   .EQU R5          ;Decimal number LSB
7000          0017          ;D0=ones, D1=tens,
700C          0018          ;D2=hundreds, D3=thousands
700C D502     0023 TOP  CLR  BH          ;clear out binary MSB
700E 420503   0024      MOV  DL,BL      ;D0 to B0
7011 730F03   0025      AND  #0Fh, BL   ;convert D0
7014          0026          ;
7014 1205     0027      MOV  DL,A       ;D1*10=D1*8+D1*2
7016 23F0     0028      AND  #0F0h,A    ;isolate D1
7018 C0       0029      MOV  A,B       ;B=D1*16
7019 D701     0030      SWAP R1        ;B=D1
701B BC       0031      RR   A         ;A=D1*16/2=D1*8
701C CE       0032      RL   B         ;B=D1*2
701D 68       0033      ADD  B,A       ;A=D1*10 (D1*8+D1*2)
701E 480003   0034      ADD  R0,BL     ;D1:D0 converted
7021          0035          ;
7021 3204     0036      MOV  DH,B     ;get upper two digits
7023 530F     0037      AND  #0Fh,B   ;isolate D2
7025 5C64     0038      MPY  #100,B  ;R0:R1=D2*100
7027 480103   0039      ADD  R1,BL    ;add to current total
702A 490002   0040      ADC  R0,BH    ;D2:D1:D0 converted
702D          0041          ;
702D 1204     0042      MOV  DH,A     ;isolate D3
702F 23F0     0043      AND  #0F0h,A  ;A=D3 * 16
7031 C0       0044      MOV  A,B     ;B=D3 * 16
7032 CD       0045      RRC  B      ;B=D3 * 8
7033 68       0046      ADD  B,A     ;A=D3 * 24
7034 4A0003   0047      SUB  R0,BL   ;BH:BL=BH:BL-24*D3
7037 7B0002   0048      SBB  #0,BH   ;
703A B0       0049      CLRC          ;setup for rotate
703B CD       0050      RRC  B      ;B=D3*4
703C 480102   0051      ADD  R1,BH   ;BH:BL=BH:BL+D3*4*256
703F          0052          ;

```

## 14.6.7 BCD String Addition

The following subroutine uses the addition instruction to add two multi-digit numbers together. Each number is a packed BCD string, less than 256 bytes (512 digits), stored at memory locations STR1 and STR2. This routine adds the two strings together and places the result in STR2. The strings must be stored with the most significant byte in the lowest numbered register. The TMS370 family instruction set favors storing all numbers and addresses with the most significant byte in the lower numbered location.

Register	Before	After	Function
A	XX	??	Accumulator
B	XX	0	Length of string
R2	XX	??	Temporary save register
STR1	BINARY MSB	no change	BCD string
STR2	BINARY LSB	STR1 + STR2	Target string, 6 bytes max

```

0000 ;Decimal Addition Subroutine. Stack must have 3 available bytes.
0000 ;On output: STR2 = STR1 + STR2
0000      0001      .TEXT      7000h      ;absolute start address
80E0      0002 STR1      .EQU      80E0h      ;start of first string
80F0      0003 STR2      .EQU      80F0h      ;start of second string
7000      0004      ;and result
7000 B0      0005 ADDBCD CLRC      ;clear carry bit
7001 FB      0006      PUSH      ST      ;save status to stack
7002 AA80DF 0007 LOOP      MOV      STR1-1(B),A ;load current byte
7005 D002      0008      MOV      A,R2      ;save it in R2
7007 AA80EF 0009      MOV      STR2-1(B),A ;load next byte of STR2
700A FC      0010      POP      ST      ;restore carry from last add
700B 1E02      0011      DAC      R2,A      ;add decimal bytes
700D FB      0012      PUSH      ST      ;save the carry from this add
700E AB80EF 0013      MOV      A,STR2-1(B) ;store result
7011 CAEF      0014      DJNZ      B,LOOP      ;loop until done
7013 FC      0015      POP      ST      ;restore stack to starting
      0016      ;position
7014 F9      0017      RTS      ;back to calling routine

```

Notice the use of the indexed addressing mode to reference the bytes of the decimal strings. Also the need to push the status register between decimal additions, to save the decimal carry bit. Register B is used to keep count of the number of bytes that have been added.

### 14.6.8 Fast Parity

This routine presents a quick way to determine the parity of a byte. By exclusive ORing all the bits of the byte together, a single bit will be derived which is the even parity of the word. When exclusive ORing, an even number of 1s will combine to form a 0, leaving either an odd 1 or 0 bit. This routine keeps splitting the byte in half and exclusive ORing the two halves.

Register	Before	After	Function
A	TARGET	??	Passing byte from program
B	XX	??	
CARRY	XX	Parity	Status bit,result to calling routine

```

*****
*
*   STEP 1                               SUBROUTINE
*   Byte bits   7654 3210                TO FIND
*           XOR   7654 [MSb above]       EVEN PARITY
*           =====
*           xxxx ABCD
*
*   STEP 2
*           ----->  AB CD
*                   XOR   AB [MS bits above]
*                   =====
*                   xx ab
*
*   STEP 3
*                   ---->  a b
*                           XOR   a [MS bit]
*                           =====
*                           x P   {answer}
*
*****
0000      0001      .TEXT   7000h      ;absolute start address
7000 C0    0002 PARITY MOV    A,B       ;duplicate the target byte
7001 B7    0003 SWAP    A           ;line up the ms nibble with the 1s
7002      0004                ;nibble
7002 65    0005 XOR     B,A       ;exclusive OR the nibbles to get a
7003      0006                ;nibble answer
7003 C0    0007 MOV    A,B       ;duplicate the nibble answer
7004 BC    0008 RR     A           ;line up bits 0,1 of the answers to
7005      0009                ;bits
7005 BC    0010 RR     A           ;2, 3 of the answer
7006 65    0011 XOR    B,A       ;XOR to get a new 2-bit answer
7007 C0    0012 MOV    A,B       ;duplicate this 2 bit answer
7008 BC    0013 RR     A           ;line up bit 0 with bit 1
7009 65    0014 XOR    B,A       ;XOR to get final even parity answer
700A BC    0015 RR     A           ;rotate answer into the carry bit
700B      0016                ;and bit 7
700B F9    0017 RTS                ;carry = 0 = even # of 1's
700C      0018                ;carry = 1 = odd # of 1's
700C      0019                ;use JC, JN or JNC in next executed
700C      0020                ;instruction

```



## 14.6.9 Bubble Sort

This routine will sort up to 256 bytes using the bubble sort method. Longer tables could be sorted using the indirect addressing mode.

Register	Function
A	Temporary Storage Register
B	Index into the Table
R2	Holds flag to indicate a byte swap has been made

```

0000          0001      .TEXT  7000h          ;absolute start address
2000          0002 TABLE .EQU  2000h          ;start of data table in RAM
0002          0003 FLAG  .EQU  R2             ;'swap has been made' flag
7000 D502     0004 SORT  CLR  FLAG            ;reset swap flag
7002 52FF     0005      MOV  #0FFh,          ;load table offset value
7004 AA2000   0006 LOOP1 MOV  TABLE(B),A    ;look at entry in table
7007 AD1FFF   0007      CMP  TABLE-1(B),A    ;look at next lower byte
700A 0B**     0008      JHS  LOOP2            ;if higher or equal, skip to
700C          0009      ;next value
700C D302     0010      INC  FLAG            ;entry is not lower, set swap
700E          0011      ;flag
700E B8       0012      PUSH A              ;store upper byte
700F AA1FFF   0013      MOV  TABLE-1(B),A    ;take lower byte
7012 AB2000   0014      MOV  A, TABLE(B)      ;put where upper was
7015 B9       0015      POP  A              ;get the old upper byte
7016 AB1FFF   0016      MOV  A, TABLE-1(B)    ;put where the lower byte was
7019 CAE9     0017 LOOP2 DJNZ  B, LOOP1       ;loop until all the table
701B          0018      ;is looked at
701B 76FF02E1 0019      BTJO #0FFh, FLAG, SORT ;if swap was made, then
701F          0020      ;resweep table
701F F9       0021      RTS              ;if no swap was made, then
          0022      ;table is done

```

### 14.6.10 Table Search

Table searches are efficiently performed by using the CMPA (Compare Register A Extended) instruction. In the following example, a 150 byte table is searched for a match with a 6-byte string.

Register	Before	After	Function
A	XX	??	
B	XX	??	
R2	XX	??	Table Length
TABLE	XX	no change	Long string in table
STRING	XX	no change	Target string, 6 bytes max

```

0000          0001  .TEXT  7000h          ;absolute start address
2000          0002  TABLE .EQU  2000          ;start of data table in RAM
000A          0003  STRING .EQU  R10          ;start of target string,
7000          0004                                     ;6 bytes max
7000 729602   0005  SEARCH  MOV    #150,R2      ;table length = 150 bytes
7003 5206     0006  LOOP1   MOV    #6,B        ;string length = 6 bytes
4005 D602     0007  LOOP2   XCHB  R2          ;swap pointers, long string in B
7007 C2       0008          DEC    B        ;reduce index into table
7008 07**     0009          JNC    NOFIND   ;table end? if so, no match found
700A AA2000   0010          MOV    TABLE(B),A ;load test character
700D D602     0011          XCHB  R2          ;swap pointers, string pointer in
700F AD0009   0012          CMP    STRING-1(B),A ;match?
7012 06EF     0013          JNE    LOOP1     ;if not, reset string pointer
7014                                     ;else test
7014 CAEF     0014          DJNZ  B,LOOP2    ;next character
7016          0015  MATCH   .EQU  $          ;match found
7016          0016  NOFIND  .EQU  $          ;no match found
7016          0017

```

The indexed addressing mode is used in this example and has the capability to search a 256-byte string, if needed. Register B alternates between a pointer into the 6 byte test string and a pointer into the longer table string.

## 14.6.11 16-by-16 (32-Bit) Multiplication

This example multiplies the 16 bit value in register pair R2,R3 by the value in register pair R4,R5. The results are stored in R6,R7,R8,R9, and Register A and B are altered.

```

*****
*      16-BIT MPY:                XH      XL      X VALUE
*      X      YH      YL      Y VALUE
*
*      XLYLm  XLYL1      1 = LSB
*      XHYLm  XHYL1      m = MSB
*      XLYHm  XLYH1
*      + XHYHm  XHYH1
*
*      RSLT3  RSLT2  RSLT1  RSLT0
*****
XH      .EQU  R2      ;higher operand of X
XL      .EQU  R3      ;lower operand of X
YH      .EQU  R4      ;higher operand of Y
YL      .EQU  R5      ;lower operand of Y
RSLT3   .EQU  R6      ;MSB of the final result
RSLT2   .EQU  R7
RSLT1   .EQU  R8
RSLT0   .EQU  R9      ;LSB of the final result

MPY32   CLR      RSLT2      ;clear the present value
        CLR      RSLT3
        MPY      XL,YL      ;multiply LSB's
        MOVW    B,RSLT0     ;store in result register 0
        MPY      XH,YL      ;get XHYL
        ADD     R1,RSLT1     ;add to existing result XLYL
        ADC     R0,RSLT2     ;add carry if present
        ADC     #0,RSLT3     ;add if carry present
        MPY      XL,YH      ;multiply to get XLYH
        ADD     R1,RSLT1     ;add to existing result XLYL+XHYL
        ADC     R0,RSLT2     ;add to existing results and carry
        ADC     #0,RSLT3     ;add if carry present
        MPY      XH,YH      ;multiply MSB's
        ADD     R1,RSLT2     ;add once again to the result register
        ADC     R0,RSLT3     ;do the final add to the result reg
        RTS

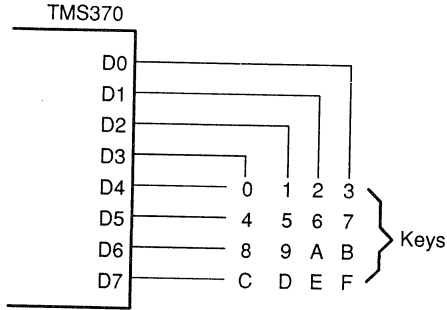
```

### 14.6.12 Keyboard Scan

This routine reads a 16 key keyboard, returns the hex digit of the key and debounces the key to avoid noise. A valid key flag is set when a new key is found.

14

Figure 14-14. Keyboard Scan Values



REGISTER	BEFORE	AFTER NO KEY	AFTER NEW KEY	FUNCTION
A	XX	0	COLUMN	Temporary
B	XX	0	ROW	Temporary
R2	XX	16	KEY #	Temp store for Key value
R3	OLD KEY	0FFh	KEY #	Holds key pressed now
R4	DEBOUNCED	0	0	Debounce counter, old key or new
R5	GENERAL BITS	?xxxxxx0	?xxxxxx1	One bit of register is 1 if new key

```

0000          0001      .TEXT 07000h      ;
0002          0002 FLAG  .EQU R2          ;"swap has been made" flag
002F          0003 DDIR  .EQU P02F        ;Port D data direction register
002E          0004 DDATA .EQU P02E        ;Port D data register
7000          0005          ;THESE ASSIGNMENTS NEED TO BE
7000          0006          ;DONE IN THE MAIN INITIALIZATION
7000          0007          ;
7000 F7002E  0008 START MOV  #00,DDATA    ;clear these registers
7003 720005  0009          MOV  #0,R5     ;clear register that say key found
7006 F7F02F  0010          MOV  #0F0h,DDIR ;set data direction register 4
7009          0011          ;output,
7009          0012          ;4 input
7009          0013          ;THIS IS THE BEGINNING OF THE
7009          0014          ;KEYBOARD SCAN ROUTINE
7009          0015          ;
7009 5208    0016 GETKEY MOV  #8,B        ;initialize row pointer
700B D502    0017          CLR  R2          ;
700D CF      0018 LOOP  RLC  B            ;select next row
700E 03**    0019          JC   NOKEY     ;last row? if so no key was found.
7010 780402  0020          ADD  #4,R2     ;add number of keys/row to key
7013          0021          ;accumulator
7013 512E    0022          MOV  B,DDATA   ;activate row
7015 802E    0023          MOV  DDATA,A  ;read columns
7017 F7002E  0024          MOV  #0,DDATA  ;clear row
701A 230F    0025          AND  #0Fh,A   ;isolate column data
701C 02EF    0026          JZ   LOOP      ;if no keys found then check next
701E          0027          ;row
701E D202    0028 KEYLSB DEC  R2          ;decrement column offset
7020 BD      0029          RRC  A          ;find column
7021 07FB    0030          JNC  KEYLSB    ;if not column then, try again
7023          0031          ;
7023 4D0203  0032 NEWKEY CMP  R2,R3      ;is the new key the same as the old
7026          0033          ;key
7026 02**    0034          JEQ  DEBONS   ;if it is then debounce it
7028 420203  0035          MOV  R2,R3     ;brand new key, move it to current
702B          0036          ;key value
702B 720704  0037          MOV  #07,R4   ;set up debounce count, debounce 7
702E          0038          ;times
702E 7D0204  0039 DEBONS CMP  #2,R4     ;is the debounce count 1 or 0?
7031 09**    0040          JL   GOODKY   ;
7033 DA04D3  0041          DJNZ  R4,GETKEY ;if greater than 1 then debounce is
7036          0042          ;not finished, go read key again
7036 770104** 0043 GOODKY BTJZ #01,R4,NONEW ;if debounce count = 0 then key
703A          0044          ;was here last time
703A D204    0045          DEC  R4          ;if it was one this is a new valid
703C          0046          ;key, make old key
703C          0047          ;
703C 740105  0048          OR   #1,R5     ;set new key flag in BIT register,
703F          0049          ;the
703F F9      0050          RTS          ;found new key so return to main
7040          0051          ;calling routine uses this flag
7040 72FF03  0052 NOKEY MOV  #0FFh,R3    ;no key was found, set key value to
7043          0053          ;unique
7043          0054          ;value
7043 F9      0055 NONEW RTS          ;if jumped to NONEW it is still the
7044          0056          ;same key
7044          0057          ;held down do nothing

```

## 14.6.13 Divide 1

The routine divides a 16-bit number by an 8-bit number to give a 16-bit quotient and an 8-bit remainder. The DIV instruction is used to accomplish this task.

```

0000          0021          .TEXT 7000h      ;
700B          0022 OVERFLOW .EQU R7        ;
700B          0023          ;divisor      -R3, quotient LSB-R5
700B          0024          ;dividend MSB-R1, quotient MSB-R4
700B          0025          ;dividend LSB-R2, remainder -B
700B          0026          ;uses R0
700B          0027          ;
700B B5       0028 DIVIDE8  CLR A         ;clear MSB of first dividend
700C F4F803   0029          DIV R3,A      ;divide MSB of dividend to get MSB
700F 08**     0030          JV OVERF      ;exit if overflow
7011 D004     0031          MOV A,R4      ;quotient. Move MSB of quotient
7013          0032          ;to storage.
7013 62       0033          MOV B,A     ;move remainder to MSB of dividend
7014 3202     0034          MOV R2,B    ;move dividend LSB to LSB position
7016 F4F803   0035          DIV R3,A     ;divide to get quotient LSB and
7019          0036          ;remainder
7019 08**     0037          JV OVERF      ;exit if overflow
701B D005     0038          MOV A,R5    ;store the quotient LSB next to MSB
701D F9       0039          RTS         ;remainder in B
701E          0040          ;
701E D311     0041 OVERF   INC OVERFLOW ;set bit 0 if overflow
7020 F9       0042          RTS         ;

```

## 14.6.14 Divide Instruction 2

This program divides a 16-bit dividend by a 16-bit divisor and produces a 16-bit quotient with a 16-bit remainder. All numbers are unsigned positive integers. All values can range from 0 to FFFFh. The same principle can be applied to larger or smaller divide routines to allow different sizes of quotients, dividends, divisors, and remainders.

```

0000          0026          .TEXT 7000h
700B          0027 ;          Before          After
700B          0028 ;          A =          Remainder MSB
700B          0029 ;          B =          Remainder LSB
700B          0030 ;          R2= Dividend MSB Quotient MSB
700B          0031 ;          R3= Dividend LSB Quotient LSB
700B          0032 ;          R4= Divisor MSB Divisor MSB
700B          0033 ;          R5= Divisor LSB Divisor LSB
700B          0034 ;          R6= XXX          Zero
700B          0035 ;
700B          0036
700B 721006 0037 DIV16 MOV #16,R6          ;Set loop counter to 16,
700E          0038          ;one for each quotient bit
700E B5       0039          CLR A          ;
700F C5       0040          CLR B          ;Initialize result register
7010 DF03     0041 DIVLOP RLC R3          ;Multiply dividend by 2
7012 DF02     0042          RLC R2          ;
7014 CF       0043          RLC B          ;Shift dividend into A:B for
7015 BF       0044          RLC A          ;comparison to divisor
7016 07**     0045          JNC SKIP1          ;Check for possible error
7018 3A05     0046          SUB R5,B          ;condition that results when
701A 1B04     0047          SBB R4,A          ;a 1 is shifted past the MSB,
701C F8       0048          SETC          ;Correct by subtracting
701D          0049          ;divisor and setting carry.
701D 00**     0050          JMP DIVEND          ;If MSb=1 then subtract is
701F          0051          ;possible
701F 1D04     0052 SKIP1 CMP R4,A          ;Compare MSBs of dividend
7021          0053          ;and divisor
7021 07**     0054          JNC DIVEND          ;Jump if divisor is bigger
7023 06**     0055          JNE MSBNE          ;If equal compare LSBs.
7025 3D05     0056          CMP R5,B          ;Compare LSBs.
7027 07**     0057          JNC DIVEND          ;Jump if divisor is bigger
7029 3A05     0058 MSBNE SUB R5,B          ;If smaller, subtract divisor
702B 1B04     0059          SBB R4,A          ;from dividend. Carry gets
702D          0060          ;folded into next rotate and
702D          0061          ;gets doubled each time.
702D DA06E0 0062 DIVEND DJNZ R6,DIVLOP          ;Next bit, is divide done?
7030 DF03     0063          RLC R3          ;Finish last rotate.
7032 DF02     0064          RLC R2          ;
7034          0065

```





Introduction	1
Assembly Language Instruction Set	13
TMS370 Family Devices	2
Design Aids	14
CPU and Memory Organization	3
Development Support	15
System and Digital I/O Configuration	4
Electrical Specifications	16
Interrupts and System Reset	5
Customer Information	17
EEPROM Modules	6
Appendices	A-H
Timer 1 Module	7
Timer 2 Module	8
Serial Communications Interface (SCI) Port	9
Serial Peripheral Interface (SPI) Module	10
Analog-to-Digital Converter Module	11
TMS370 Programmable Acquisition and Control Timer	12



# Development Support

Texas Instruments provides extensive development support for the TMS370 family. The TMS370 series unified development support tools consists of the following components:

- ❑ Assembly Language Tools
- ❑ Design Kit for Evaluation of TMS370 Family
- ❑ Extended Development Support (XDS/11) System with associated software
- ❑ Extended Development Support (XDS/22) System with associated software
- ❑ Extended Development Support (PACT XDS/22) System for devices with the PACT module with associated software
- ❑ EEPROM Programmer
- ❑ Form Factor Emulators (FFE's) for prototype and small production runs.

These development tools are designed to work with an IBM compatible PC. The TMS370 system designer can use a text editor to generate the assembler source code, then use the assembly language tools to assemble the source modules and link the assembled modules. The object file may then be tested with either an XDS system, a Design Kit, or a FFE device, all of which provide full speed emulation. The XDS/22 systems provide realtime breakpoint/trace/timing functions to facilitate hardware and software integration during system development.

The EEPROM Programmer provides the means of programming the programmable memory of any TMS370 device. The TMS370C8xx and TMS370C7xx devices can be used for prototyping and emulation of masked ROM parts, as well as a medium for submitting the program to TI for masked ROM production.

This chapter discusses key features of the TMS370 development tools. For a detailed description of system components, refer to the documents listed in Section 1.5. The topics included in this chapter are as follow:

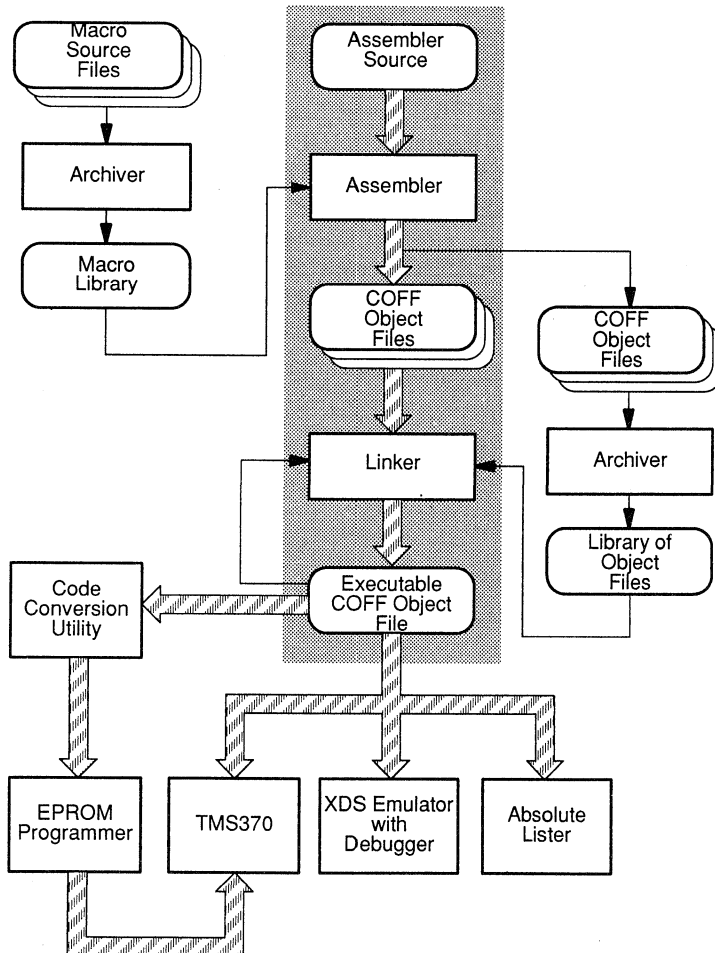
<b>Section</b>	<b>Page</b>
15.1 The Assembly Language Tools .....	15-3
15.2 The XDS/22 System .....	15-8
15.3 The PACT XDS/22 System .....	15-9
15.4 The XDS/11 System .....	15-10
15.5 XDS System Configuration Requirements .....	15-11
15.6 Design Kit .....	15-12
15.7 Standard Debugger Interface .....	15-14
15.8 XDS System Operating Considerations .....	15-24
15.9 The TI EEPROM Programmer .....	15-25
15.10 Form Factor Emulators .....	15-27

15

## 15.1 The Assembly Language Tools

The TMS370 assembly language tools (Figure 15–1) include an assembler, linker, archiver, and a code conversion utility. These tools are available from TI on a 5 1/4 inch floppy diskette for IBM compatible PCs. The PC should be running PC-DOS or MS-DOS version 3.0 or later, and have at least 512 K bytes of memory space available for the assembler and linker operation.

Figure 15–1. Software Development Flow



### 15.1.1 The Assembler

The TMS370 assembler translates assembly language source files into machine language object files. Source files can contain instructions, assembler directives, and macro directives. The assembler directives control various aspects of the assembly process, such as the source listing format, symbol definition, conditional assembly blocks, macro library definition, and how the machine code is placed into the TMS370 memory space.

15

The format of the object files created by the assembler and linker is called *Common Object File Format* (COFF). COFF encourages and facilitates modular programming. It allows the assembler to maintain a section program counter (SPC) for each section of object code generated. The SPC defines the virtual program memory addresses assigned to the associated object code. The assembler uses the SPC while it builds the symbol table.

The symbol tables contained in the COFF object files allow the XDS debugger to provide the user with **symbolic debugging**. The XDS also provides for direct referencing of any assembler label and arithmetic expressions involving assembler labels when the labels are part of the downloaded COFF object file. The COFF object files are also used by the TI EEPROM programmer to form a PC memory image of the data loaded for programming.

## 15.1.2 The Linker

The TMS370 linker creates executable modules by combining COFF object files. The concept of user definable COFF *sections* is basic to the linker operation. The linker accepts several types of files as input :

- ❑ Relocatable COFF object files produced by the TMS370 assembler
- ❑ Command files
- ❑ Archive object libraries
- ❑ Output modules created by a previous linker run (these are referred to as partially linked files)

As the linker combines object files, it performs the following tasks:

- ❑ Allocates sections into the target system's configured memory
- ❑ Relocates symbols and sections to assign them to final addresses
- ❑ Resolves undefined external references between input files

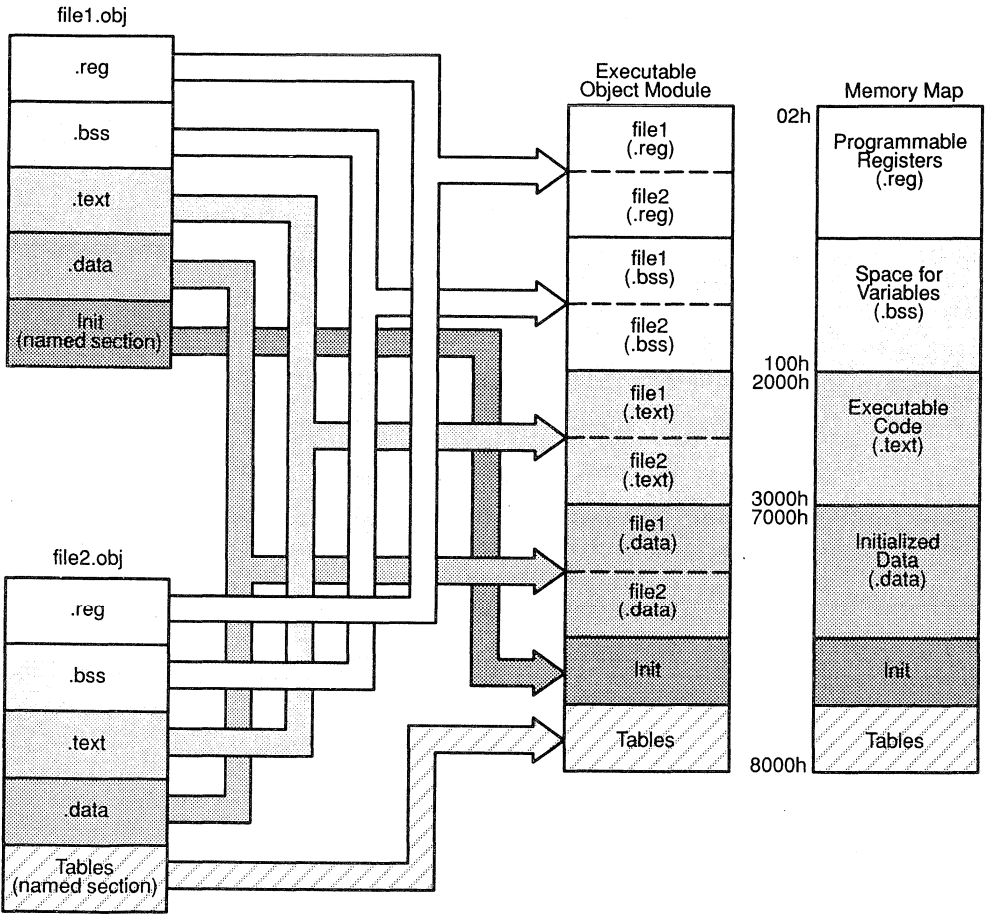
The linker supports a command language similar to C that controls memory configuration, section definition, and address binding. The language supports expression assignment and evaluation, and provides two powerful directives, MEMORY and SECTIONS, that allow you to:

- ❑ Define a memory model that conforms to target system memory
- ❑ Combine object file sections
- ❑ Allocate sections into specific areas of memory
- ❑ Define overlaid memory structures
- ❑ Define or redefine global symbols at link time

Figure 15–2 shows the operation of the linker on two source code files. Each file has been assembled and contains four default sections and one named section. The various sections are arranged in the order dictated either by the linker's default method or by a user supplied control file. The executable object module shows the combined sections, and the memory map indicates the location of the sections in memory.

Figure 15-2. Linker Output Generation

15





### 15.1.3 The Archiver

The archiver provides file management by allowing a group of files to be collected into a single library. For example, macros can be collected by the archiver, then fetched by the assembler as directed by the source file. Object modules can also be collected into a library for convenient access by the linker. While not necessary for program development, the archiver can provide valuable organization in the building of the executable COFF object file.

15

### 15.1.4 Code Conversion Utility

The code conversion utility converts COFF object files to Tektronics, Intel (hex and word), and TI tagged object formats. Code conversion is necessary when not using the TI EEPROM Programmer, since some other (non-TI) EPROM programmers do not accept COFF object files as input. Code in the Intel hex object format can be downloaded to most EPROM programmers.

## 15.2 The XDS/22 System

The XDS/22 system is a self-contained package that provides full-speed, in-circuit emulation and debugging functions required for program development of the TMS370 family devices. Key features of the XDS/22 emulation function include:

- ❑ 20 MHz full-speed in-circuit emulation of all TMS370 family members
- ❑ Realtime hardware breakpoint/trace/time analysis capabilities
- ❑ Execution of programs from internal XDS/22 memory (64K) or target memory
- ❑ Support of both microcomputer and microprocessor modes
- ❑ Large trace buffer, 2048 samples
- ❑ Full logic tracing with logic analyzer interface cable

The XDS/22 system hardware includes a chassis, power supply, power and interfacing cables, and a three board set consisting of an emulator, communications board, and a breakpoint/trace/timing board. At the heart of the XDS/22 system is a special system emulator chip containing all the peripheral modules and I/O line circuits that precisely duplicate the TMS370's logic and performance. The internal XDS/22 memory can be used to emulate on-chip ROM and/or external memory.

The XDS/22 debugger function is provided by software which runs on a PC. The software provides interactive control of the emulator with the following features:

- ❑ Window oriented user interface with menu-driven command structure
- ❑ Direct symbolic referencing from downloaded assembly symbol tables
- ❑ Full symbolic expression analysis that recognizes all assembly language operators
- ❑ Symbolic reverse assembler
- ❑ Ability to display and change registers and memory

### **15.3 The PACT XDS/22 System**

The PACT XDS/22 system was specifically developed for emulating and debugging the TMS370Cx3x devices with the PACT module. In addition to the standard emulator board, it has a piggy-back board for emulating the PACT module. This XDS can also be used for emulating the other standard TMS370 devices.

## 15.4 The XDS/11 System

The XDS/11 supports real-time in-circuit emulation of most of the TMS370 family of devices. The XDS/11 does not support the TMS370 devices with the PACT module.

15

The XDS/11 system contains two boards: a communication board that connects to the PC and the emulator board. Both these boards are enclosed in a chassis. Attached to the emulator is a target cable with the same pinout as the device being emulated. This connector plugs directly into the application system's circuit board using the same socket that would normally hold the TMS370 microcontroller. The XDS/11 is supplied with either a 68-pin PLCC cable or a 28-pin PLCC/DIP cable.

A regulated five-volt power supply with a current capability of three amps is required to operate the XDS/11. This is not supplied with the XDS/11.

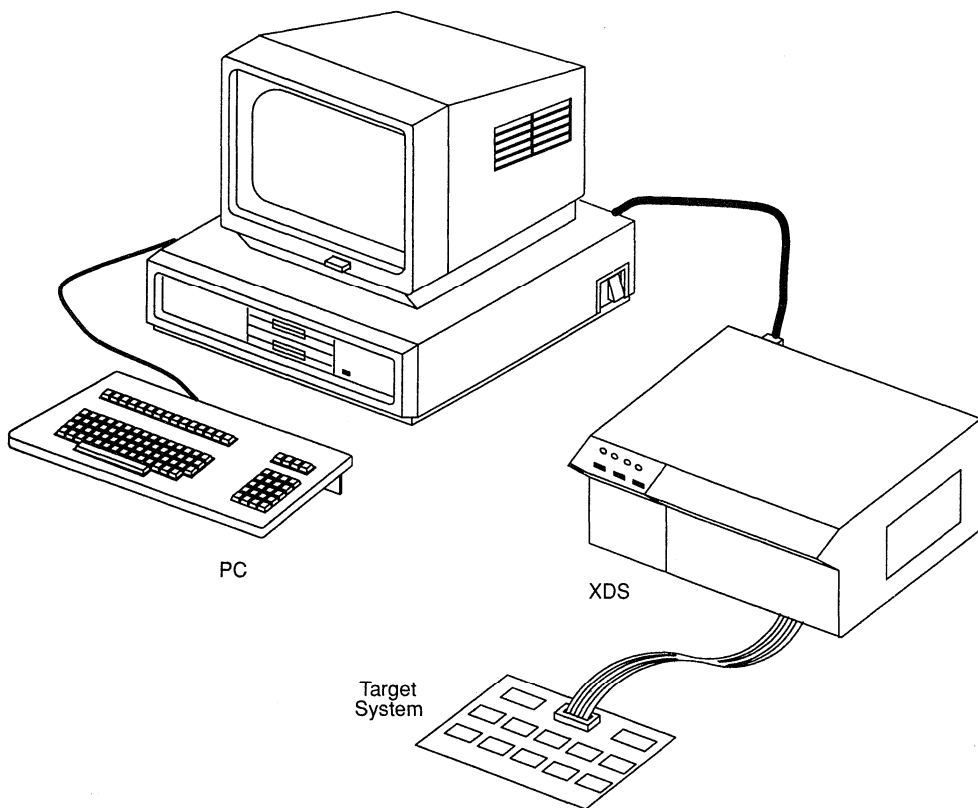
Functionally, the XDS/11 system is identical to the XDS/22 system except that the breakpoint/trace/timing functions of XDS/22 systems are not available. The XDS/11 uses a debugger interface similar to that of the XDS/22 systems. For details, refer to the Section 15.7.

## 15.5 XDS System Configuration Requirements

A functional XDS system configuration consists of the XDS system and the following user-supplied components:

- ❑ IBM compatible PC with 512 K bytes minimum and serial communication port
- ❑ MS/PC-DOS version 3.0 or later
- ❑ Monitor (preferably color, to better highlight field and value changes)

**Figure 15-3. Typical XDS System Configuration**



## 15.6 Design Kit

The TMS370 Design Kit helps designers to quickly analyze the feasibility of using a member of the TMS370 family for their application. This low cost evaluation tool enables the analysis of hardware and software capabilities of the TMS370 family by actually using the TMS370 devices. The Design Kit can not be used for evaluating the PACT module on TMS370Cx3x parts. The Design Kit includes an application board, evaluation assembler, code converter, application board program, TMS370 Family Data Manual and application board User's Guide. The Design Kit package provides the following features:

- ❑ The capability to upload and download code
- ❑ Access to any register or memory location
- ❑ Ability to read and modify memory locations
- ❑ Ability to execute programs and software routines
- ❑ Ability to single-step executable instructions
- ❑ Software break points to halt program execution at selected addresses
- ❑ Ability to program the EEPROM and UVEPROM contained within the TMS370Cx1x and TMS370Cx5x devices.
- ❑ Assembler on PC
- ❑ Wire-Wrap proto-area
- ❑ Patch assembler in debugger mode
- ❑ Reverse assembler

### 15.6.1 Modes of Operation

The application board operates in two modes, the TTY mode and the Debugger mode.

#### 15.6.1.1 TTY Mode

The TTY mode can talk to almost any equipment using a simple ASCII serial RS-232-C type protocol. This includes Dumb terminals, PCs running terminal interface programs such as XTALK or PROCOMM, or IBM incompatible computers. The TTY mode is most useful when you do not have access to an IBM compatible PC or if you need simple operations or programming. It presents a simple scrolling display. Two letter commands control the operation of the board. The TTY mode also has several board test commands to check the operation of a suspect board. The following features are available only with TTY mode:

- System tests
- Upload memory
- Verify memory
- Find bytes
- Move memory
- Compare memory
- Block Program
- Direct read of Analog Pin
- Load on-chip EEPROM from on-board UVEPROM
- Use any computer in Dumb terminal mode
- Reverse assembler with cycle times

### **15.6.1.2 Debugger Mode**

The debugger mode uses an IBM compatible PC to present a window oriented user interface with menu driven commands. There are many advantages of using the debugger mode of operation. All the important data is displayed on the screen at one time including user defined expressions. Symbols and labels can be used instead of absolute addresses which constantly change. A simple patch assembler is available to change a few lines of code. The following features are available only with debugger mode:

- Full screen display with Windows
- Patch assembler
- Display files
- Program symbols available/symbolic debugging
- Direct COFF download
- Return to DOS system

To utilize the debugger mode of the Design Kit, the PC must meet the XDS system configuration requirements as discussed in Section 15.5. For more information on the debugger function refer to Section 15.7.

## 15.7 Standard Debugger Interface

The Standard Debugger Interface is software that runs on a PC. This interface has a standard screen appearance for the products supported (Design Kit, XDS/11, and XDS/22 systems). This allows the user to move from Design Kit to in-circuit emulators without having to learn a new interface, only the new features.

15

This program provides window oriented, interactive programming that facilitates the development of applications for TMS370 family devices. The user develops an executable COFF object file using a text editor and the TMS370 assembly language tools. The debugger function allows the object file to be downloaded into the target device or the emulator memory of the XDS system. The debugger and emulator functions then provide evaluation of microprocessor/program operation.

A user debugging a system needs to focus on a number of different areas such as the code being executed, the registers of the target machine, and the variables in the program. The debugger aids this by using a menu-oriented command language that allows control of the debugging process. The command language is designed to be both simple for the inexperienced user and efficient for the expert. This is accomplished by limiting command menus to just one or two levels, so that nearly everything in the debugger can be controlled by a simple two-letter command without wasting key-strokes. Commands requiring additional input or qualification provide a prompt for that information or a menu of subcommands.

The top level screen (Figure 15–4) of the debugger consists of the following elements:

- ❑ Available command menu
- ❑ Status line
- ❑ Information windows
- ❑ Function key reminder line



Figure 15-4. XDS Debugger Top Level Screen

Debug:  Display  Execute  Reg Mem  Point  Eval  Config  Tr/Time  Load Module  Halt  **8**

HALTED: POINT

code		cpu registers	
START:		PC 7002	SP 01 ST cnzv21
1 7000 52E0	MOV E0,B	A 00	B E0 40 010000
7002 FD	LDSP	r file stack	
BEGIN:		R2 00	R3 00 SP (01) E0
7003 88702F5D	MOVW 702F,R93	R4 00	R5 00 - 1(00) 00
7007 720F5F	MOV F,R95	R6 00	R7 00 - 2(FF) 00
loop:		R8 00	R9 00 - 3(FE) 00
2 700A 8800085B	MOVW 0008,R91	R10 00	R11 00 - 4(FD) 00
700E 8E701C	CALL @XFER	R12 00	R13 00 - 5(FC) 00
7011 7A485D	SUB 48,R93	R14 00	R15 00 - 6(FB) 00
	display	R16 00	R17 00 - 7(FA) 00
7000 52 E0 FD 88 70 2F 5D 72	R...p.]r	R18 00	R19 00 - 8(F9) 00
7008 0F 5F 88 00 08 5B 8E 70	....[.p	R20 00	R21 00 - 9(F8) 00
7010 1C 7A 48 5D 7B 00 5C DA	.zH](.\.	expressions	
7018 5F F0 00 E7 72 50 5E 9A	....rP^.	system cntl reg0	10000000b
7020 5D 9B 5B 70 01 5D 70 01	]..[p.]p.	system cntl reg1	00000000b
7028 5B DA 5E F3 F9 F9 FA 20	[.^....	system cntl reg2	00001000b
7030 20 20 20 20 20 20 20 20		interrupt a cntl	00000000b
7038 20 20 20 20 20 20 20 20		interrupt b cntl	00000000b
7040 20 20 20 20 20 20 20 20		interrupt c cntl	00000000b
7048 20 20 20 20 20 20 20 20		timer A counter	00018h

Inspect  Update  Help

15

The available command menu at the top of the screen displays the single keystroke commands that can be used from that menu. Pressing the indicated key either performs the associated action or calls up a prompt or menu of subcommands. The status line indicates the current status of the system. The function key reminder line displays several functions provided by the function [F] keys.

15

The following subsections describe the information windows, which take up the area under the status line and above the function key reminder line. Some windows are based on virtual buffers in the XDS system, which means that the debugger keeps track of more information than can be displayed at one time. To view all of the information, the user simply scrolls through the window. The debugger automatically accesses the emulator whenever scrolling passes beyond the buffer's current contents. The user can easily move from window to window to make specific changes and view data. Information displayed in the windows is updated automatically whenever the microcontroller stops running, and manually with a function key. Updated or new values are highlighted for easy recognition.

### 15.7.1 Code Window

The code window (located in the upper left corner) displays disassembled object code being debugged. The current instruction at the PC is identified with a highlighted address. Also, instructions at which simple breakpoints have been set are marked with a numeric breakpoint ID to the left of the address. Immediate values in instructions are displayed in hexadecimal.

Simple changes to the user program may be accomplished by using the patch assembler function.

#### 15.7.1.1 Display Window

The display window is located in the lower left corner of the window area. This window displays miscellaneous debugger information such as:

- ❑ Memory, dumped in hexadecimal format
- ❑ Peripheral file register contents
- ❑ Symbols in the symbol table
- ❑ Object module names (with current module highlighted)
- ❑ PC text file with available control keys for find functions

This window can be scrolled up and down.

#### 15.7.1.2 CPU Registers Window

The contents of five registers (A, B, PC, SP, and ST) are displayed in the CPU registers window in the upper right corner. The contents of these regis-

ters can be modified from this window. Scrolling is not needed since all available information is shown.

### 15.7.1.3 Register File Window

The register file window (located to the right of center) shows the contents of the register file, 20 registers at a time. The data can be scrolled up or down, and changed at will.

### 15.7.1.4 Stack Window

The stack window, located to the far right of center, displays the contents of the current program stack within the register file. The stack window differs from the register file window in that

- 1) When updated, the window automatically changes the display to reflect the offset of each register from the current top of stack and
- 2) The registers are displayed in reverse order, so that higher on the stack corresponds to higher in the window.

### 15.7.1.5 Expression Window

The expression window (located in the lower right corner) is used to display arbitrary expressions specified by the user. When prompted by the debugger for an address or a value, an arbitrary complex expression may be entered. The debugger evaluates expressions using the symbol table and the emulator. Expressions can consist of numeric constants, symbols, and register names, separated by operators. All expressions are evaluated and displayed as a 16-bit value in both hexadecimal and decimal. For example, if the expression "PC + 23h" is entered and the current value in the PC is 7000h, the debugger displays "PC+23h = 07023h = 28707". The debugger then prompts for a save upon which the expression is displayed in the window.

## 15.7.2 Breakpoint/Trace/Timing Functions

The Breakpoint, Trace and Timing (BTT) board of the XDS/22 systems (XDS/22 and PACT XDS/22) monitors various microcontroller activities at the hardware level. The board can be programmed to take certain actions triggered by the occurrence of specified qualifiers, depending on what *state* the board is in. The BTT is always in one of four states (Figure 15-5). Up to four actions can be qualified per state, with certain restrictions. A qualified event in one state can cause a transition to another state with a new set of parameters and actions becoming affective. This allows multilevel or sequenced breakpoints to be used for complex debugging problems.

The occurrence of specified qualifiers results in an action taken by the BTT board. These qualifiers consist of the following:

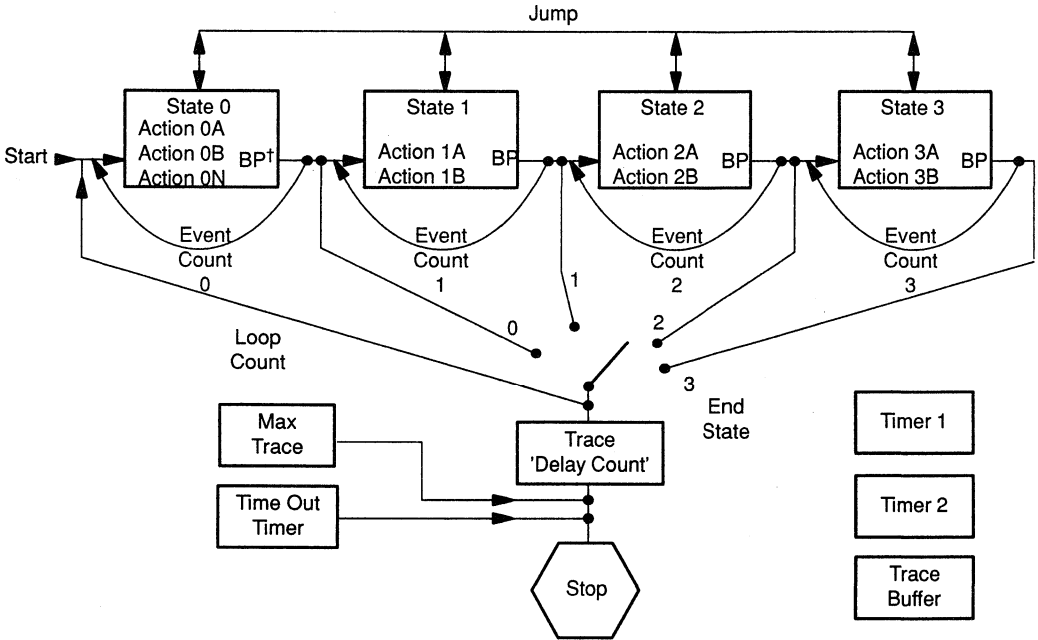
- ADDRESS** The BTT monitors the memory bus during all memory cycles. Two address qualifiers can be used to trigger an action on a particular address or range of addresses. These can be used to define two distinct single point addresses, an inclusive range (any address within the range qualifiers), or an exclusive range (any address outside the range qualifiers). A mask can be specified to selectively ignore some or all of the external qualifier bits.
- DATA** The BTT also monitors the value on the data bus during each memory cycle. Two data qualifiers can be used with the data bus in exactly the same way as the two address qualifiers are used with the address bus. A mask can be specified to selectively ignore some or all of the external qualifier bits.
- CYCLE** Memory cycle types can also be used as qualifiers to trigger an action. Memory cycle types are read, write, and instruction fetch. Any one or any combination of these cycles can be qualified.
- EXTERNAL** The BTT can monitor the logic level of the eight external probe lines. A qualifier can be used to trigger an action on a particular value from these inputs. A mask can be specified to selectively ignore some or all of the external qualifier bits.

Actions that can be taken by the BTT board on the basis of the above qualifiers consist of the following:

- BP/EVENT** Triggering a breakpoint/event may cause a hardware breakpoint, decrement the state counter or transfer control to the next (or beginning) state.
- TRACE** A cycle which satisfies the TRACE qualifiers will be stored in the TRACE buffer. This provides a history of the program execution for later inspection.
- JUMP** The BTT has four separate states in which different sets of actions can be specified. The JUMP action forces a transition into a different state when triggered.
- POINT TIMER** The BTT has two timers that can be started or stopped by qualified actions. The POINT TIMER action uses the two address qualifiers to control one timer. The timer is started when the first address is qualified and stopped when the other address is qualified.

**RANGE TIMER** The RANGE TIMER actions also control the BTT timers but differ from the point timer action in that one action starts a timer and a separate action stops it. Thus, there are actually two actions, "range timer start" and "range timer stop."

Figure 15-5. BTT Operation (XDS/22 Systems Only)



† BP – Breakpoint/Event

Figure 15-6. BTT Screen (XDS/22 Systems Only)

15

```

BTT: Reset Load Save Xit Aabort

STATE 0

ACTION: Trace      ACTION: BP/event  ACTION: RangeTimer  ACTION: RangeTimer
addr = START      addr = xloop        start # 1           stop # 1
.. BEGIN          cycles IAQ          addr = START       addr = BEGIN
mask 0FFFFh      extern IGNORE      cycles ALL          cycles ALL
cycles IAQ        extern IGNORE      extern IGNORE       extern IGNORE
extern IGNORE

-----available----- locals----- globals-----
BP/event 0          mode: ADDR ONLY    delay count: 100
Trace 0           trace mode: TRIX   max trace: 0
Jump 0            event count: 100  end state: 0
PointTimer 0
RangerTimer 0    time out: 0008.000 000 000

F3 Edit F2 Last      F4 NextState F5 Local F6 Global      F10 Help
    
```

The trace sample function of the BTT board provides snapshot storage of bus cycle activity. Up to 2047 samples, each 104 bits wide, can be stored by the circular trace buffer. As more samples are stored, the buffer wraps around, replacing the oldest samples with the newest ones. Each sample contains the following information:

- ❑ Address and data bus values
- ❑ Bus-cycle access type (read, write, instruction fetch)
- ❑ External logic-probe values
- ❑ BTT state and breakpoint/event indicators
- ❑ Time stamp from free-running timer (hours through nanoseconds)

The trace buffer screen provides a chronological display of the trace samples. Figure 15–7 shows the screen display for the trace functions.

Figure 15-7. Trace Sample Screen (XDS/22 Systems Only)

15

Inspect Trace:  Position  Top  Bottom  Lookup  Save Timers  FormatTime  Execute  
 Sample = 909, Total = 2047

INDX	ST	n	m	s	ms	vs	ms	EXTRNA	CYC	ADDR	DATA	R	V	VS	AS
0909	0			0:00:00.417	084	600	11111111	WRITE	005D	57					
0910	0			0:00:00.417	084	800	11111111	IAQ	7014	7B	SBB				
0911	0			0:00:00.417	085	000	11111111	READ	7015	00					
0912	0			0:00:00.417	085	200	11111111	READ	7016	5C					
0913	0			0:00:00.417	085	300	11111111	READ	005C	70					
0914	0			0:00:00.417	085	400	11111111	WRITE	005C	70					
0915	0			0:00:00.417	085	600	11111111	IAQ	7017	DA	DJNZ	R95			
0916	0			0:00:00.417	085	800	11111111	READ	7018	5F					
0917	0			0:00:00.417	085	900	11111111	READ	005F	0B					
0918	0			0:00:00.417	086	000	11111111	WRITE	005F	0A					
0919	0			0:00:00.417	086	200	11111111	READ	7019	F0					
0920	0	E		0:00:00.417	086	600	11111111	IAQ	700A	88	MOVW				
0921	0			0:00:00.417	086	800	11111111	READ	700B	00					
0922	0			0:00:00.417	087	000	11111111	READ	700C	08					
0923	0			0:00:00.417	087	300	11111111	READ	700D	5B					
0924	0			0:00:00.417	087	500	11111111	WRITE	005B	08					
0925	0			0:00:00.417	087	700	11111111	WRITE	005A	00					

timer 1: 0:00:00.409 973 800      timer 2: 0:00:00.000 000 000  
 timer 1 avg: 0:00:00.000 399 500

F1       F4       F10



The BTT board has three timers. Two timers are controlled by event qualification, while the third is free running. The timers allow timing statistics to be taken, such as the time the microcontroller spends executing a particular routine. This aids the programmer in developing efficient code and evaluating system performance. The display format of the trace buffer screen can be altered by the user to show one of the following statistics determined by the timers:

- Time stamps referenced from starting time
- Delta or time between trace samples
- Time samples referenced from selected trace sample

## 15.8 XDS System Operating Considerations

The emulation hardware of the XDS systems (XDS/11, XDS/22, and PACT XDS/22) generally exhibits the same characteristics as the actual TMS370 devices. There are, however, a few subtle differences that the designer should be aware of when building a prototype circuit for use with the XDS system.

15

### 15.8.1 Mode Control Pin

To allow the XDS systems to function without being attached to a target system, a 20 k $\Omega$  pull-down resistor is connected to the mode control line in the XDS unit. This increases the minimum input current needed to drive this line high ( $I_I$ ) from 100  $\mu$ A to 300  $\mu$ A. If a pull-up resistor is used to put the device in the microprocessor mode, then its value should be no greater than 1 k $\Omega$  when using the XDS system.

### 15.8.2 Reset

The XDS systems add an analog switch and a 51 k $\Omega$  pull up resistor to the reset line. This increases the current necessary to pull this line to a logic low from 10  $\mu$ A to 100  $\mu$ A.

### 15.8.3 Clock In

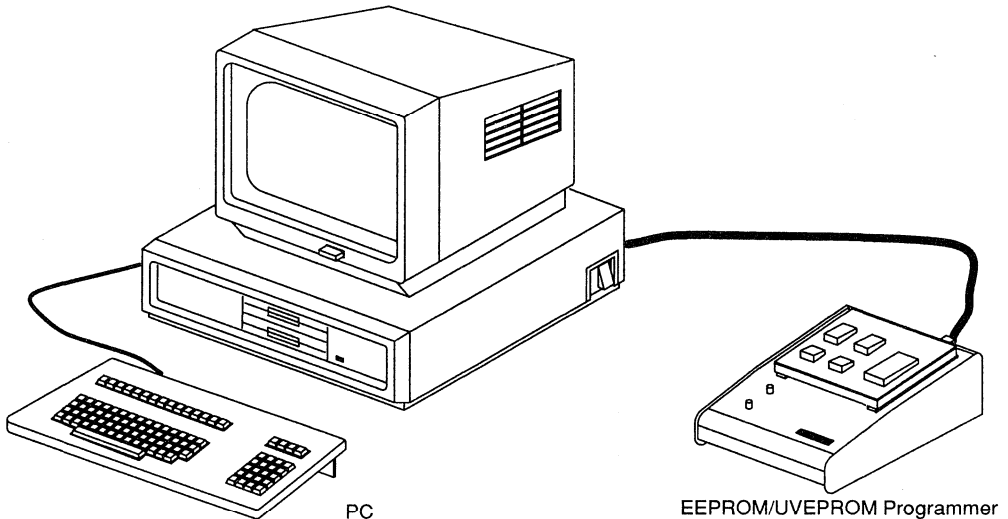
The XDS systems cannot drive a crystal located on the target system. Therefore, either the crystal must be moved to socket Y1 of the emulator board, or an external clock signal connected to the XTAL2/CLKIN pin. The external clock signal must meet the  $V_{IH}$  specifications for the XTAL2/CLKIN described in Chapter 16.

## 15.9 The TI EEPROM Programmer

The TI EEPROM Programmer is an interactive, menu driven system that provides a method of programming TMS370 prototyping devices and industry-standard UVEPROMs. The Programmer can interact either directly with a PC or through the XDS for easy programming, modifying, and reading of the target memory device. Sockets are provided for all members of the TMS370 family and UVEPROMs, such as the 2732, 2764; 27128, and 27256.

The TI EEPROM Programmer system (as shown in Figure 15–8) consists of the TI EEPROM Programmer and an IBM compatible PC running EEPROM programmer software under MS/PC-DOS. The TI EEPROM Programmer comes complete with power and interface cables, EEPROM programmer software for the PC, and a user guide.

**Figure 15–8.** Typical EEPROM/UVEPROM Programmer Configuration



The programmer software provides both interactive and limited batch control with the following features:

- ❑ Window oriented screens with a menu-driven command structure
- ❑ Block erase for TMS370 family devices only
- ❑ Programming mode bit selection for TMS370 family devices only
- ❑ Relocatable programming capability which allows source data bytes within certain address range to be programmed at specified address
- ❑ Reverse assembly code display
- ❑ Intermediate PC memory which provides a storage area for downloading a COFF file or uploading from devices
- ❑ Ability to inspect and patch loaded data in PC memory
- ❑ Ability to generate a COFF file from PC memory content
- ❑ Ability to save or load Programmer Configuration to or from Configuration/Batch file

The TI EEPROM Programmer, unlike most other EPROM programmers, can use COFF object files developed by the assembler/linker as input for programming the TMS370 devices. Most other EPROM programmers will require that the object files be converted into some other object format before programming.

5

## 15.10 Form Factor Emulators

The TMS370 Form Factor Emulators (FFE) are devices where the program ROM has been replaced by a programmable program memory, such as EPROM or EEPROM. These devices are packaged in the same or similar package as masked ROM parts so they can plug into the same target application as the final masked device. This capability provides form factor pre-production parts with zero lead time for field testing and production qualifications, thereby reducing the overall time to market. This also allows the capability for applications with small production runs. All TMS370 devices can be programmed directly from the assembler or linker output file with the TI EEPROM Programmer. The Application Board can program the corresponding devices for which it demonstrates the capabilities. Below is a table that shows the TMS370 ROM devices (available at time of printing) and their corresponding Form Factor Emulator (FFE).

15

**Table 15–1. FFE Support of ROM Devices**

TMS370 ROM Device	FFE
TMS370C010 TMS370C310	TMS370C810
TMS370C050 TMS370C350	TMS370C850 or TMS370C756
TMS370C052 TMS370C352 TMS370C056 TMS370C356	TMS370C756
TMS370C032 TMS370C332	TMS370C732

**Note:** ROM-less devices (TMS370C15x, TMS370C25x) do not need FFEs.



Introduction	1
Assembly Language Instruction Set	13
TMS370 Family Devices	2
Design Aids	14
CPU and Memory Organization	3
Development Support	15
System and Digital I/O Configuration	4
Electrical Specifications	16
Interrupts and System Reset	5
Customer Information	17
EEPROM Modules	6
Appendices	A-H
Timer 1 Module	7
Timer 2 Module	8
Serial Communications Interface (SCI) Port	9
Serial Peripheral Interface (SPI) Module	10
Analog-to-Digital Converter Module	11
TMS370 Programmable Acquisition and Control Timer	12





# Electrical Specifications

---

---

---

---

This chapter contains electrical and timing information for the TMS370 family devices. Specifications that apply to the TMS370Cx1x devices are presented first, followed by specifications that apply to the TMS370Cx3x devices, and then by specifications for the TMS370Cx5x devices.

<b>Section</b>	<b>Page</b>
16.1 TMS370Cx1x Specifications .....	16-2
16.2 TMS370Cx3x Specifications .....	16-11
16.3 TMS370Cx5x Specifications .....	16-21

## 16.1 TMS370Cx1x Specifications

The specifications given in the following tables apply to the devices in the TMS370Cx1x category.

- **TMS370Cx1x** devices include the TMS370C010, TMS370C310, and TMS370C810

**Table 16–1. Absolute Maximum Ratings over Operational Free-Air Temperature Range (unless otherwise noted)<sup>†</sup>**

Supply voltage range, $V_{CC}$ (See Note 2.)	– 0.3 V to 7 V
Input voltage range: All pins except MC	– 0.3 V to $V_{CC} + 0.3$ V
MC	– 0.3 V to 14 V
Input clamp current, $I_{IK}$ ( $V_I < 0$ or $V_I > V_{CC}$ )	$\pm 20$ mA
Output clamp current, $I_{OK}$ ( $V_O < 0$ or $V_O > V_{CC}$ )	$\pm 20$ mA
Continuous output current per buffer, $I_O$ ( $V_O = 0$ to $V_{CC}$ ) (See Note 1.)	$\pm 10$ mA
Maximum $I_{CC}$ current	170 mA
Maximum $I_{SS}$ current	–170 mA
Continuous power dissipation	500 mW
Storage temperature range	– 65°C to 150°C

- Notes:** 1) Electrical characteristics are specified with all output buffers loaded with the specified  $I_O$  current. Exceeding the specified  $I_O$  current in any buffer may affect the levels on other buffers.
- 2) Unless otherwise noted, all voltage values are with respect to  $V_{SS}$ .

**† Stresses beyond those listed under Absolute Maximum Ratings may cause permanent damage to the device. This is a stress rating only and functional operation of the device at these or any other conditions beyond those indicated in the Recommended Operating Conditions section of this specification is not implied. Exposure to absolute maximum rated conditions for extended periods may affect device reliability.**

16

**Table 16–2. Recommended Operating Conditions**

Parameter		Min	Nom	Max	Unit
$V_{CC}$	Supply voltage (see Note 2.)	4.5	5	5.5	V
$V_{CC}$	RAM data retention supply voltage (See Note 3.)	3		5.5	V
$V_{IL}$	Low-level input voltage	All pins except MC	$V_{SS}$	0.8	V
		MC, normal operation	$V_{SS}$	0.3	
$V_{IH}$	High-level input voltage	All pins except MC, XTAL2/CLKIN, and $\overline{RESET}$	2	$V_{CC}$	V
		MC/Write Protect Override (WPO)	11.7	13	
		XTAL2/CLKIN	$0.8 V_{CC}$	$V_{CC}$	
		$\overline{RESET}$	$0.7 V_{CC}$	$V_{CC}$	
$T_A$	Operating free-air temperature	A version	-40	85	$^{\circ}C$
		L version	0	70	$^{\circ}C$

**Notes:** 2) Unless otherwise noted, all voltages are with respect to  $V_{SS}$ .

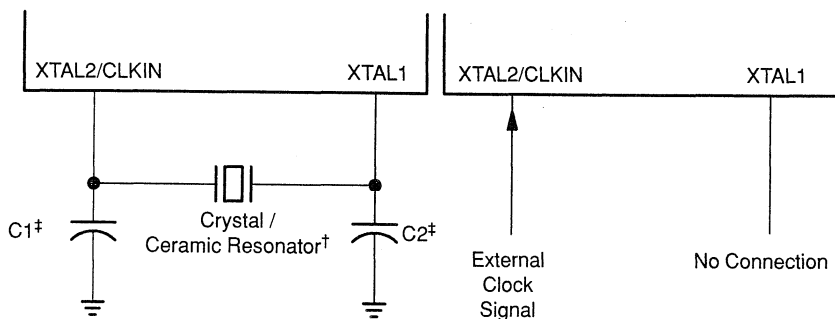
3) To guarantee RAM data retention from 3.0 V to 4.5 V,  $\overline{RESET}$  must be externally asserted and released only while  $V_{CC}$  is within the recommended operating range of 4.5 V to 5.5V.

**Table 16–3. Electrical Characteristics over Full Ranges of Recommended Operating Conditions**

Parameter		Test Conditions	Min	Typ	Max	Unit
$V_{OL}$	Low-level output voltage	$I_{OL} = 1.4 \text{ mA}$		0.4		V
$V_{OH}$	High-level output voltage	$I_{OH} = -50 \mu\text{A}$	0.9 $V_{CC}$			V
		$I_{OH} = -2 \text{ mA}$	2.4			
$I_I$	Input current	MC	$0 \text{ V} \leq V_I \leq 0.3 \text{ V}$		10	$\mu\text{A}$
			$0.3 \text{ V} < V_I \leq 13 \text{ V}$		650	
		I/O pins	$0 \text{ V} \leq V_I \leq V_{CC}$		$\pm 10$	
$I_{OL}$	Low-level output current	$V_{OL} = 0.4 \text{ V}$	1.4			mA
$I_{OH}$	High-level output current	$V_{OH} = 0.9 V_{CC}$	-50			$\mu\text{A}$
		$V_{OH} = 2.4 \text{ V}$	-2			mA
$I_{CC}$	Supply current (Operating mode) Osc Power bit = 0 (see Note 6)	TMS370Cx10 †	Notes 4 and 5		36	mA
		TMS370C810	CLKIN = 20 MHz		80	
		TMS370Cx10 †	Notes 4 and 5		25	
		TMS370C810	CLKIN = 12 MHz		56	
		TMS370Cx10 †	Notes 4 and 5		11	
		TMS370C810	CLKIN = 2 MHz		25	
$I_{CC}$	Supply current (Standby mode) Osc Power bit = 0 (See Note 7)	TMS370Cx10 †	Notes 4 and 5		17	mA
		TMS370C810	CLKIN = 20 MHz		28	
		TMS370Cx10 †	Notes 4 and 5		11	
		TMS370C810	CLKIN = 12 MHz		18	
		TMS370Cx10 †	Notes 4 and 5		3.5	
		TMS370C810	CLKIN = 2 MHz		6	
$I_{CC}$	Supply current (Standby mode) Osc Power bit = 1 (See Note 8)	TMS370Cx10 †	Notes 4 and 5 CLKIN = 12 MHz		8.6	mA
			Notes 4 and 5 CLKIN = 2 MHz		3.0	
$I_{CC}$	Supply current (Halt Mode)	TMS370Cx10 †	Note 4		30	$\mu\text{A}$
		TMS370C810	XTAL2/CLKIN < 0.2 V		100	

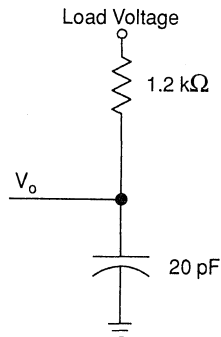
† All TMS370Cx10 devices except TMS370C810.

- Notes:**
- Single chip mode, ports configured as inputs, or outputs with no load. All inputs  $\leq 0.2 \text{ V}$  or  $\geq V_{CC} - 0.2 \text{ V}$ .
  - XTAL2/CLKIN is driven with an external square wave signal with 50% duty cycle and rise and fall times less than 10 ns. Currents may be higher with a crystal oscillator. At 20 MHz this extra current =  $.01 \text{ mA} \times (\text{total load capacitance} + \text{crystal capacitance in pF})$ .
  - Maximum operating current for TMS370Cx10 = 1.4 (CLKIN) + 8 mA.  
Maximum operating current for TMS370C810 = 3.06 (CLKIN) + 19 mA.
  - Maximum standby current for TMS370Cx10 = 0.75 (CLKIN) + 2 mA.  
Maximum standby current for TMS370C810 = 1.2 (CLKIN) + 3.6 mA.
  - Maximum standby current for TMS370Cx10 = 0.56 (CLKIN) + 1.9 mA. (Osc power bit valid only from 2 MHz to 12 MHz.)

**Figure 16–1. Recommended Crystal/Clock Connections**

† The crystal/ceramic resonator frequency is four times the reciprocal of the system clock period.

‡ The values of C1 and C2 are typically 15 pF. See manufacturer's recommendations for ceramic resonators.

**Figure 16–2. Typical Output Load Circuit §**

Case 1:  $V_O = V_{OH} = 2.4 \text{ V}$ ; Load Voltage = 0 V

Case 2:  $V_O = V_{OL} = 0.4 \text{ V}$ ; Load Voltage = 2.1 V

§ All measurements are made with the pin loading as shown unless otherwise noted. All measurements are made with XTAL2/CLKIN driven by an external square wave signal with a 50% duty cycle and rise and fall times less than 10 ns unless otherwise stated.

## 16.1.1 Timing Parameter Symbology

Timing parameter symbols have been created in accordance with JEDEC Standard 100. In order to shorten the symbols, some of the pin names and other related terminology have been abbreviated as follows:

AR	Array	S	Slave mode
B	Byte	SIMO	SPISIMO
CI	XTAL2/CLKIN	SOMI	SPISOMI
CO	CLKOUT	SPC	SPICLK
PGM	Program		

Lowercase subscripts and their meanings are:

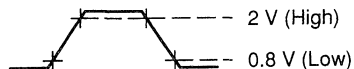
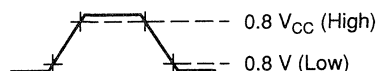
c	cycle time (period)	su	setup time
d	delay time	v	valid time
f	fall time	w	pulse duration (width)
r	rise time	x	oscillator

The following additional letters are used with these meanings:

H	High
L	Low
V	Valid

## 16.1.2 Parameter Measurement Information

All timings are measured between high and low measurement points as indicated in the figures below.



**XTAL2/CLKIN Measurement Points**

**General Measurement Points**

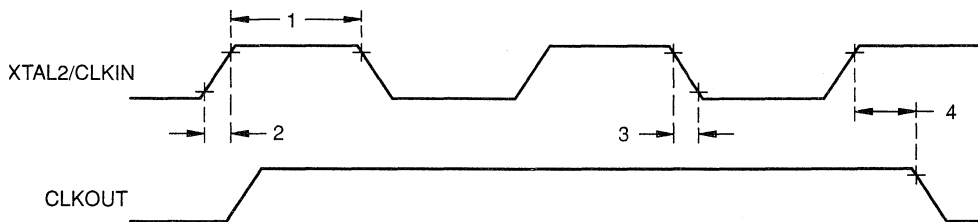
**Table 16–4. External Clocking Requirements**<sup>†</sup>

No.	Parameter	Min	Nom	Max	Unit
1	$t_{w(Cl)}$ XTAL2/CLKIN pulse duration (Note 9.)	20			ns
2	$t_{r(Cl)}$ XTAL2/CLKIN rise time			30	ns
3	$t_{f(Cl)}$ XTAL2/CLKIN fall time			30	ns
	CLKIN Crystal operating frequency	2		20	MHz

<sup>†</sup> For  $V_{IL}$  and  $V_{IH}$ , refer to Recommended Operating Conditions.

**Notes:** 9) This pulse may be either a high pulse, as illustrated, which extends from the earliest valid high to the final valid high in an XTAL2/CLKIN cycle, or a low pulse, which extends from the earliest valid low to the final valid low in an XTAL2/CLKIN cycle.

**Figure 16–3. External Clock Timing**

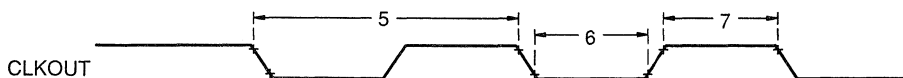


**Table 16–5. Switching Characteristics and Timing Requirements**<sup>‡</sup>

No.	Parameter	Min	Max	Unit
4	$t_{d(CIH-COL)}$ Delay time, XTAL2/CLKIN rise to CLKOUT fall		100	ns
5	$t_c$ CLKOUT (system clock) cycle time	200	2000	ns
6	$t_{w(COL)}$ CLKOUT low pulse duration	$0.5t_c - 20$	$0.5t_c$	ns
7	$t_{w(COH)}$ CLKOUT high pulse duration	$0.5t_c$	$0.5t_c + 20$	ns

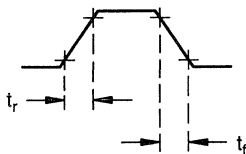
<sup>‡</sup>  $t_c$  = system clock cycle time = 4/CLKIN.

**Figure 16–4. CLKOUT Timing**



**Table 16–6. General Purpose Output Signal Switching Time Requirements**

Parameter		Min	Nom	Max	Unit
$t_r$	Rise time			45	ns
$t_f$	Fall time			45	ns

**Figure 16–5. Switching Time Measurement Points**

16

**Table 16–7. Recommended EEPROM Timing Requirements for Programming**

Parameter		Min	Nom	Max	Unit
$t_{w(PGM)B}$	Programming duration to insure valid data is stored (byte mode)	10			ms
$t_{w(PGM)AR}$	Programming duration to insure valid data is stored (array mode)	20			ms



**Table 16–8. SPI Master External Timing Characteristics** †

No.	Parameter	Min	Max	Unit
38	$t_c(\text{SPC})$ SPICLK cycle time	$2t_c$	$256t_c$	ns
39	$t_w(\text{SPCL})$ SPICLK low pulse duration	$t_c - 45$	$0.5t_c(\text{SPC}) + 45$	ns
40	$t_w(\text{SPCH})$ SPICLK high pulse duration	$t_c - 45$	$0.5t_c(\text{SPC}) + 45$	ns
41	$t_d(\text{SPCL-SIMOV})$ Delay time, SPISIMO valid after SPICLK low (Polarity = 1)	- 50	50	ns
42	$t_v(\text{SPCH-SIMO})$ SPISIMO data valid after SPICLK high (Polarity = 1).	$t_w(\text{SPCH}) - 50$		ns

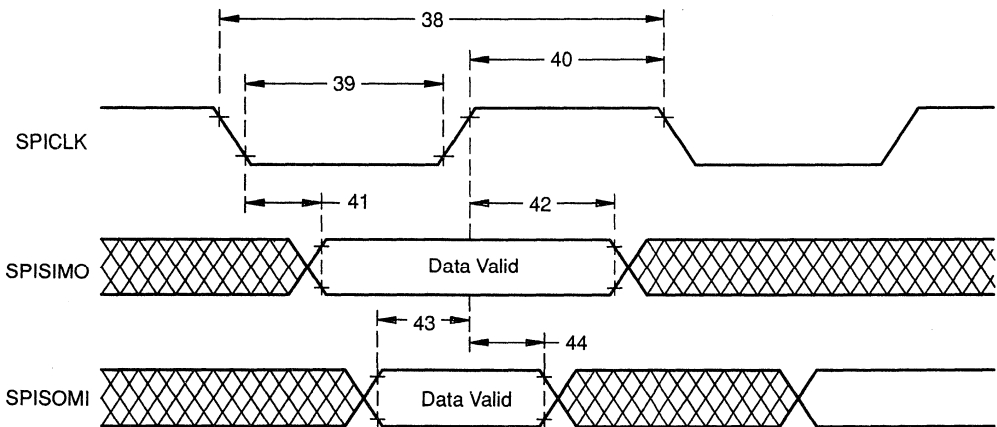
16

**Table 16–9. SPI Master External Timing Requirements** †

No.	Parameter	Min	Max	Unit
43	$t_{su}(\text{SOMI-SPCH})$ SPISOMI setup time to SPICLK high (Polarity = 1)	$0.25t_c + 150$		ns
44	$t_v(\text{SPCH-SOMI})$ SPISOMI data valid after SPICLK high (Polarity = 1)	0		ns

†  $t_c$  = system clock cycle time =  $4/\text{CLKIN}$ .

**Figure 16–6. SPI Master External Timing**



**Note:** The diagram above is for Polarity = 1. SPICLK is inverted from above diagram when Polarity = 0.

**Table 16–10. SPI Slave External Timing Characteristics†**

No.	Parameter	Min	Max	Unit
48	$t_{d(SPCL-SOMIV)S}$ Delay time, SPISOMI valid after SPICLK low (Polarity = 1)		$3.25t_c + 125$	ns
49	$t_{v(SPCH-SOMI)S}$ SPISOMI data valid after SPICLK high (Polarity = 1)	$t_{w(SPCH)S}$		ns

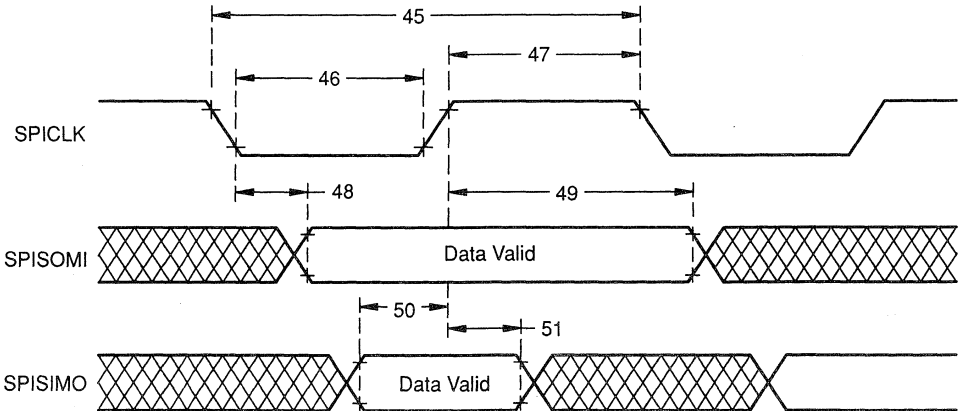
**Table 16–11. SPI Slave External Timing Requirements†**

16

No.	Parameter	Min	Max	Unit
45	$t_{c(SPC)S}$ SPICLK cycle time	$8t_c$		ns
46	$t_{w(SPCL)S}$ SPICLK low pulse duration	$4t_c - 45$	$0.5t_{c(SPC)S} + 45$	ns
47	$t_{w(SPCH)S}$ SPICLK high pulse duration	$4t_c - 45$	$0.5t_{c(SPC)S} + 45$	ns
50	$t_{su(SIMO-SPCH)S}$ SPISIMO setup time to SPICLK high (Polarity = 1)	0		ns
51	$t_{v(SPCH-SIMO)S}$ SPISIMO data valid after SPICLK high (Polarity = 1)	$3t_c + 100$		ns

†  $t_c$  = system clock cycle time = 4/CLKIN.

**Figure 16–7. SPI Slave External Timing**



- Notes:** 1) The diagram above is for Polarity = 1. SPICLK is inverted from above diagram when Polarity = 0.  
 2) As a slave, the SPICLK pin is used as the input for the serial clock, which is supplied from the network master.

## 16.2 TMS370Cx3x Specifications

The specifications given in the following tables apply to the devices in the TMS370Cx3x category.

- **TMS370Cx3x** devices include the TMS370C032, TMS370C332, and TMS370C732

**Table 16–12. Absolute Maximum Ratings over Operating Free-air Temperature Range (unless otherwise noted)<sup>†</sup>**

Supply voltage range, $V_{CC}$ (See Note 2.)	–0.3 V to 7 V
Input voltage range: All pins except MC	–0.3 V to $V_{CC} + 0.3$ V
MC	–0.3 V to 14 V
Input clamp current, $I_{IK}$ ( $V_I < 0$ or $V_I > V_{CC}$ )	$\pm 20$ mA
Output clamp current, $I_{OK}$ ( $V_O < 0$ or $V_O > V_{CC}$ )	$\pm 20$ mA
Continuous output current per buffer, $I_O$ ( $V_O = 0$ to $V_{CC}$ ) (See Note 1.)	$\pm 10$ mA
Maximum $I_{CC}$ current	170 mA
Maximum $I_{SS}$ current	–170 mA
Continuous power dissipation	800 mW
Storage temperature range	–65°C to 150°C

- Notes:**
- 1) Electrical characteristics are specified with all output buffers loaded with the specified  $I_O$  current. Exceeding the specified  $I_O$  current in any buffer may affect the levels on other buffers.
  - 2) Unless otherwise noted, all voltage values are with respect to  $V_{SS}$ .

**† Stresses beyond those listed under Absolute Maximum Ratings may cause permanent damage to the device. This is a stress rating only and functional operation of the device at these or any other conditions beyond those indicated in the Recommended Operating Conditions section of this specification is not implied. Exposure to absolute maximum rated conditions for extended periods may affect device reliability.**

**Table 16–13. Recommended Operating Conditions**

Parameter		Min	Nom	Max	Unit	
$V_{CC1}$	Supply voltage (see Note 2.)	4.5	5	5.5	V	
$V_{CC1}$	RAM data retention supply voltage (See Note 3.)	3		5.5	V	
$V_{CC3}$	Analog supply voltage (see Note 2.)	4.5	5	5.5	V	
$V_{IL}$	Low-level input voltage	All pins except MC	$V_{SS}$	0.8	V	
		MC, normal operation	$V_{SS}$	0.3		
$V_{IH}$	High-level input voltage	All pins except MC, XTAL2/CLKIN, and $\overline{RESET}$	2	$V_{CC}$	V	
		MC/Write Protect Override (WPO)	11.7	13		
		XTAL2/CLKIN	$0.8 V_{CC}$	$V_{CC}$		
		$\overline{RESET}$	$0.7 V_{CC}$	$V_{CC}$		
MC (mode control) voltage (Note 4)	EEPROM write protect override (WPO)	Microcomputer	$V_{SS}$	0.3	V	
		EEPROM programming voltage ( $V_{PP}$ )	12	12.5		13
			11.7	12		13
$T_A$	Operating free-air temperature	A version	-40	85	$^{\circ}C$	
		L version	0	70	$^{\circ}C$	

**Notes:** 2) Unless otherwise noted, all voltages are with respect to  $V_{SS}$ .

3) To guarantee RAM data retention from 3.0 V to 4.5 V,  $\overline{RESET}$  must be externally asserted and released only while  $V_{CC}$  is within the recommended operating range of 4.5 V to 5.5V.

4) The WPO mode may be selected anytime a sufficient voltage is present on the MC pin.

**Table 16–14. Electrical Characteristics Over Full Ranges of Recommended Operating Conditions**

Parameter		Test Conditions	Min	Typ	Max	Unit
$V_{OL}$	Low-level output voltage	$I_{OL} = 1.4 \text{ mA}$			0.4	V
$V_{OH}$	High-level output voltage	$I_{OH} = -50 \mu\text{A}$	$0.9 V_{CC}$			V
		$I_{OH} = -2 \text{ mA}$	2.4			
$I_I$	Input current	MC	$0 \text{ V} \leq V_I \leq 0.3 \text{ V}$		10	$\mu\text{A}$
			$0.3 \text{ V} < V_I \leq 13 \text{ V}$		650	
			$12 \text{ V} \leq V_I \leq 13 \text{ V} \ddagger$		50	
		I/O pins	$0 \text{ V} \leq V_I \leq V_{CC}$		$\pm 10$	$\mu\text{A}$
$I_{OL}$	Low-level output current	$V_{OL} = 0.4 \text{ V}$	1.4			mA
$I_{OH}$	High-level output current	$V_{OH} = 0.9 V_{CC}$	-50			$\mu\text{A}$
		$V_{OH} = 2.4 \text{ V}$	-2			mA
$I_{CC}$	Supply current (Operating mode) Osc Power bit = 0	TMS370Cx32 †	Notes 5 and 6		45	mA
		TMS370C732	CLKIN = 20 MHz		95	
		TMS370Cx32 †	Notes 5 and 6		30	
		TMS370C732	CLKIN = 12 MHz		70	
		TMS370Cx32 †	Notes 5 and 6		11	
		TMS370C732	CLKIN = 2 MHz		40	
$I_{CC}$	Supply current (Standby mode) Osc Power bit = 0	TMS370Cx32 †	Notes 5 and 6		17	mA
		TMS370C732	CLKIN = 20 MHz		28	
		TMS370Cx32 †	Notes 5 and 6		11	
		TMS370C732	CLKIN = 12 MHz		18	
		TMS370Cx32 †	Notes 5 and 6		3.5	
		TMS370C732	CLKIN = 2 MHz		6.0	
$I_{CC}$	Supply current (Standby mode) Osc Power bit = 1	TMS370Cx32 †	Notes 5 and 6 CLKIN = 12 MHz		8.6	mA
			Notes 5 and 6 CLKIN = 2 MHz		3.0	
$I_{CC}$	Supply current (Halt Mode)	TMS370Cx32 †	Note 5		30	$\mu\text{A}$
		TMS370C732	XTAL2/CLKIN < 0.2 V		100	

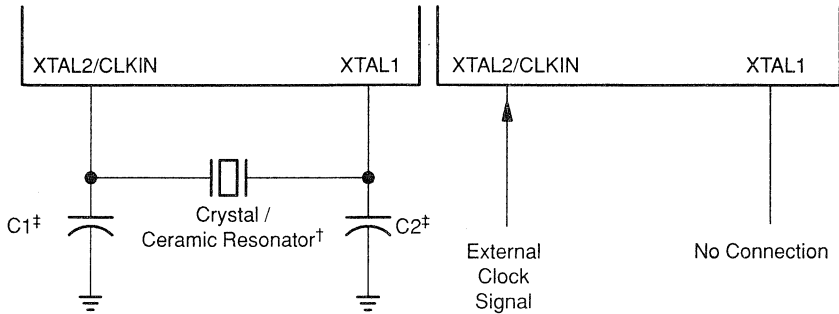
† All TMS370Cx32 devices except TMS370C732.

‡ Input current  $I_{PP}$  will be of maximum of 50 mA only when programming EPROM.

**Notes:** 5) Single chip mode, ports configured as inputs, or outputs with no load. All inputs  $\leq 0.2 \text{ V}$  or  $\geq V_{CC} - 0.2 \text{ V}$ .

6) XTAL2/CLKIN is driven with an external square wave signal with 50% duty cycle and rise and fall times less than 10 ns. Currents may be higher with a crystal oscillator. At 20 MHz this extra current =  $.01 \text{ mA} \times (\text{total load capacitance} + \text{crystal capacitance in pF})$ .

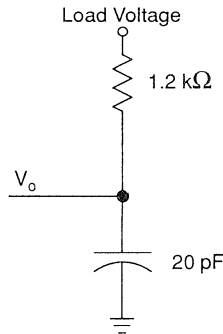
**Figure 16–8. Recommended Crystal/Clock Connections**



16

- † The crystal/ceramic resonator frequency is four times the reciprocal of the system clock period.
- ‡ The values of C1 and C2 are typically 15 pF. See manufacturer's recommendations for ceramic resonators.

**Figure 16–9. Typical Output Load Circuit §**



- Case 1:  $V_O = V_{OH} = 2.4 \text{ V}$ ; Load Voltage = 0 V
- Case 2:  $V_O = V_{OL} = 0.4 \text{ V}$ ; Load Voltage = 2.1 V

- § All measurements are made with the pin loading as shown unless otherwise noted. All measurements are made with XTAL2/CLKIN driven by an external square wave signal with a 50% duty cycle and rise and fall times less than 10 ns unless otherwise stated.

## 16.2.1 Timing Parameter Symbology

Timing parameter symbols have been created in accordance with JEDEC Standard 100. In order to shorten the symbols, some of the pin names and other related terminology have been abbreviated as follows:

AR	Array	CO	CLKOUT
B	Byte	PGM	Program
CI	XTAL2/CLKIN		

Lowercase subscripts and their meanings are:

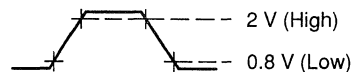
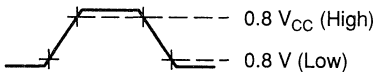
c	cycle time (period)	r	rise time
d	delay time	su	setup time
f	fall time	v	valid time
h	hold time	w	pulse duration (width)

The following additional letters are used with these meanings:

H	High	V	Valid
L	Low		

## 16.2.2 Parameter Measurement Information

All timings are measured between high and low measurement points as indicated in the figures below.



**XTAL2/CLKIN Measurement Points**

**General Measurement Points**

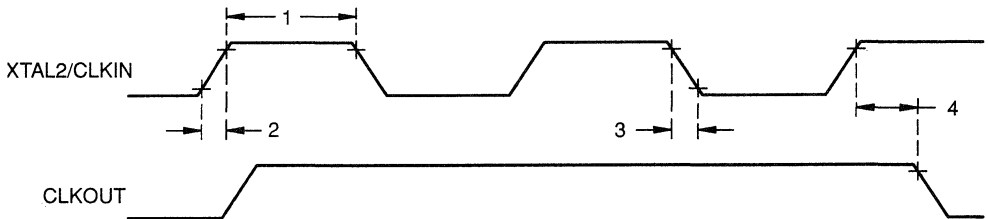
**Table 16–15. External Clocking Requirements †**

No.	Parameter	Min	Nom	Max	Unit
1	$t_{w(CL)}$ XTAL2/CLKIN pulse duration (Note 7.)	20			ns
2	$t_{r(CL)}$ XTAL2/CLKIN rise time			30	ns
3	$t_{f(CL)}$ XTAL2/CLKIN fall time			30	ns
	CLKIN Crystal operating frequency	2		20	MHz

† For  $V_{IL}$  and  $V_{IH}$ , refer to Recommended Operating Conditions.

**Notes:** 7) This pulse may be either a high pulse, as illustrated, which extends from the earliest valid high to the final valid high in an XTAL2/CLKIN cycle, or a low pulse, which extends from the earliest valid low to the final valid low in an XTAL2/CLKIN cycle.

**Figure 16–10. External Clock Timing**

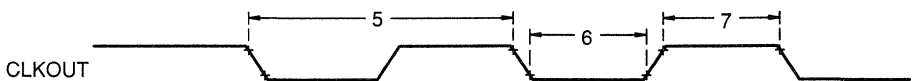


**Table 16–16. Switching Characteristics and Timing Requirements ‡**

No.	Parameter	Min	Max	Unit
4	$t_{d(CIH-COL)}$ Delay time, XTAL2/CLKIN rise to CLKOUT fall		100	ns
5	$t_c$ CLKOUT (system clock) cycle time	200	2000	ns
6	$t_{w(COL)}$ CLKOUT low pulse duration	$0.5t_c - 20$	$0.5t_c$	ns
7	$t_{w(COH)}$ CLKOUT high pulse duration	$0.5t_c$	$0.5t_c + 20$	ns

‡  $t_c$  = system clock cycle time = 4/CLKIN.

**Figure 16–11. CLKOUT Timing**

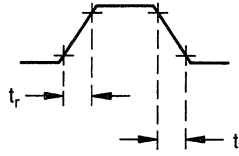




**Table 16–17. General Purpose Output Signal Switching Time Requirements**

Parameter			Min	Nom	Max	Unit
$t_r$	Rise time	INT2, INT3			45	ns
$t_f$	Fall time	INT2, INT3			45	ns

**Figure 16–12. Switching Time Measurement Points**



16

**Table 16–18. Recommended EPROM Operating Conditions for Programming**

Parameter		Min	Nom	Max	Unit
$V_{CC}$	Supply voltage	4.75		5.5	V
$V_{PP}$	Supply voltage at MC pin	12	12.5	13	V
$I_{PP}$	Supply current at MC pin during programming ( $V_{PP} = 13$ V)		30	50	mA
CLKIN	Operating crystal frequency	2		20	MHz

**Table 16–19. Recommended EPROM Timing Requirements for Programming**

Parameter		Min	Nom	Max	Unit
$t_{w(IEPGM)}$	Initial programming pulse (see Note 8)	0.95	1	1.05	ms
$t_{w(FEPGM)}$	Final programming pulse	2.85		78.75	ms

**Note 8:** Programming pulse is active when both EXE (EPCTL.0) and VPPS (EPCTL.6) are set.

**Table 16–20. Recommended EEPROM Timing Requirements for Programming**

Parameter		Min	Nom	Max	Unit
$t_{w(PGM)B}$	Programming duration to insure valid data is stored (byte mode)	10			ms
$t_{w(PGM)AR}$	Programming duration to insure valid data is stored (array mode)	20			ms

## 16.2.3 A/D Converter

The A/D Converter has a separate power bus for its analog circuitry. These pins are referred to as  $V_{CC3}$  and  $V_{SS3}$ . The purpose is to enhance A/D performance by preventing digital switching noise of the logic circuitry which may be present on  $V_{SS}$  and  $V_{CC}$  from coupling into the A/D analog stage. All A/D specifications will be given with respect to  $V_{SS3}$  unless otherwise noted.

Resolution ..... 8 bits (256 values)

Monotonic ..... Yes

Output conversion code ... 00h to FFh (00 for  $V_I \leq V_{SS3}$ ; FF for  $V_I \geq V_{ref}$ )

Conversion time (excluding sample time) .....  $164t_c$

16

**Table 16–21. Recommended Operating Conditions**

		Min	Nom	Max	Unit
$V_{CC3}$	Analog supply voltage	4.5	5	5.5	V
		$V_{CC} - 0.3$		$V_{CC} + 0.3$	
$V_{SS3}$	Analog ground	$V_{SS} - 0.3$		$V_{SS} + 0.3$	V
$V_{ref}$	Non- $V_{CC3}$ reference (See Note 9)	2.5	$V_{CC3}$	$V_{CC3} + 0.1$	V
	Analog input for conversion	$V_{SS3}$		$V_{ref}$	V

**Note 9:**  $V_{ref}$  must be stable, within  $\pm 1/2$  LSB of the required resolution, during the entire conversion time.

**Table 16–22. Operating Characteristics Over Full Ranges of Recommended Operating Conditions**

Parameter		Test Conditions	Min	Typ	Max	Unit
Absolute accuracy (See Note 10)		$V_{CC3} = 5.5 \text{ V}$ , $V_{ref} = 5.1 \text{ V}$			$\pm 1$	LSB
Differential/integral linearity error (See Notes 10 and 11)		$V_{CC3} = 5.5 \text{ V}$ , $V_{ref} = 5.1 \text{ V}$			$\pm 0.5$	LSB
$I_{CC3}$	Analog supply current	Converting			2	mA
		Non-Converting			5	$\mu\text{A}$
$I_I$	Input current, AN0–AN7	$0 \text{ V} \leq V_I \leq 5.5 \text{ V}$			2	$\mu\text{A}$
	Vref input charge current				1	mA
$Z_{ref}$	Source impedance of $V_{ref}$	$\text{XTAL2/CLKIN} \leq 12 \text{ MHz}$			24	$\text{k}\Omega$
		$12 \text{ MHz} < \text{XTAL2/CLKIN} \leq 20 \text{ MHz}$			10	$\text{k}\Omega$

- Notes:** 10) Absolute resolution = 20 mV. At  $V_{ref} = 5 \text{ V}$ , this is 1 LSB. As  $V_{ref}$  decreases, LSB size decreases and thus absolute accuracy and differential/integral linearity errors in terms of LSBs increases.
- 11) Excluding quantization error of 1/2 LSB.

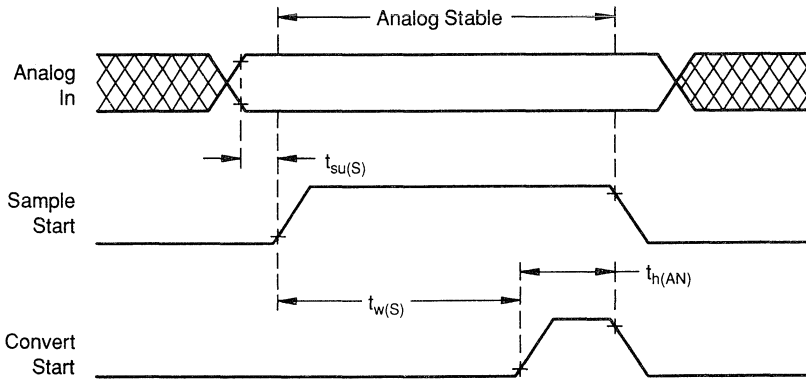
The A/D module allows complete freedom in design of the sources for the analog inputs. The period of the sample time is user-defined such that high impedance sources can be accommodated without penalty to low-impedance sources. The sample period begins when the SAMPLE START bit of the A/D Control Register (ADCTL) is set to 1. The end of the signal sample period occurs when the conversion bit (CONVERT START) of the ADCTL is set to 1. After a hold time, the converter will reset the SAMPLE START and CONVERT START bits, signaling that a conversion has started and the analog signal can be removed.

**Table 16–23. Analog Timing Requirements**

Parameter	Min	Nom	Max	Unit
$t_{su(S)}$ Analog input setup to sample command	0			ns
$t_{h(AN)}$ Analog input hold from start of conversion	$18t_c$			ns
$t_{w(S)}$ Duration of sample time per kilohm of source impedance (see Note 12)	1			$\mu\text{s}/\text{k}\Omega$

**Note 12:** The value given is valid for a signal with a source impedance greater than 1 k $\Omega$ . If the source impedance is less than 1 k $\Omega$ , use a minimum sampling time of 1  $\mu\text{s}$ .

**16** Figure 16–13. Analog Timing



## 16.3 TMS370Cx5x Specifications

The specifications given in the following tables apply to the devices in the TMS370Cx5x category.

- **TMS370Cx5x** devices include the TMS370C050, TMS370C150, TMS370C250, TMS370C350, TMS370C850, TMS370C052, TMS370C352, TMS370C056, TMS370C156, TMS370C256, TMS370C356, and TMS370C756.

**Table 16–24. Absolute Maximum Ratings over Operating Free-Air Temperature Range (unless otherwise noted)<sup>†</sup>**

Supply voltage range, $V_{CC}$ (See Note 2.)	– 0.3 V to 7 V
Input voltage range: All pins except MC	– 0.3 V to $V_{CC} + 0.3$ V
MC	– 0.3 V to 14 V
Input clamp current, $I_{IK}$ ( $V_I < 0$ or $V_I > V_{CC}$ )	$\pm 20$ mA
Output clamp current, $I_{OK}$ ( $V_O < 0$ or $V_O > V_{CC}$ )	$\pm 20$ mA
Continuous output current per buffer, $I_O$ ( $V_O = 0$ to $V_{CC}$ ) (See Note 1.)	$\pm 10$ mA
Maximum $I_{CC}$ current	170 mA
Maximum $I_{SS}$ current	–170 mA
Continuous power dissipation	1 W
Storage temperature range	– 65°C to 150°C

- Notes:** 1) Electrical characteristics are specified with all output buffers loaded with the specified  $I_O$  current. Exceeding the specified  $I_O$  current in any buffer may affect the levels on other buffers.
- 2) Unless otherwise noted, all voltage values are with respect to  $V_{SS}$ .

**† Stresses beyond those listed under Absolute Maximum Ratings may cause permanent damage to the device. This is a stress rating only and functional operation of the device at these or any other conditions beyond those indicated in the Recommended Operating Conditions section of this specification is not implied. Exposure to absolute maximum rated conditions for extended periods may affect device reliability.**

**Table 16–25. Recommended Operating Conditions**

Parameter		Min	Nom	Max	Unit	
$V_{CC1}$	Digital logic supply voltage (Note 2)	4.5	5	5.5	V	
$V_{CC1}$	RAM data retention supply voltage (Note 3)	3		5.5	V	
$V_{CC2}$	Digital I/O supply voltage (Note 2)	4.5	5	5.5	V	
$V_{CC3}$	Analog supply voltage (Note 2)	4.5	5	5.5	V	
$V_{IL}$	Low-level input voltage	All pins except MC	$V_{SS}$	0.8	V	
		MC	$V_{SS}$	0.3		
$V_{IH}$	High-level input voltage	All pins except MC and XTAL2/CLKIN and $\overline{RESET}$	2	$V_{CC}$	V	
		MC (non-WPO mode)	$V_{CC}-0.3$	$V_{CC}+0.3$		
		XTAL2/CLKIN	$0.8 V_{CC}$	$V_{CC}$		
		$\overline{RESET}$	$0.7 V_{CC}$	$V_{CC}$		
MC (mode control) voltage (Note 4)	EEPROM write protect override (WPO)	Microprocessor	$V_{CC}-0.3$	$V_{CC}+0.3$	V	
		Microcomputer	$V_{SS}$	0.3		
		EPROM programming voltage ( $V_{PP}$ )	12	12.5		13
$T_A$	Operating free-air temperature	A version	-40	85	$^{\circ}C$	
		L version	0	70	$^{\circ}C$	

- Notes:**
- 2) Unless otherwise noted, all voltages are with respect to  $V_{SS}$ .
  - 3) To guarantee RAM data retention from 3.0 V to 4.5 V,  $\overline{RESET}$  must be externally asserted and released only while  $V_{CC}$  is within the recommended operating range of 4.5 V to 5.5V.
  - 4) The basic microcomputer and microprocessor operating modes are selected by the voltage level applied to the dedicated MC pin 2 system clock cycles ( $t_C$ ) before the  $\overline{RESET}$  pin goes inactive (high). The WPO mode may be selected anytime a sufficient voltage is present on the MC pin.

**Table 16–26. Electrical Characteristics over Full Ranges of Recommended Operating Conditions**

Parameter		Test Conditions	Min	Typ	Max	Unit
$V_{OL}$	Low-level output voltage	Ports A, B, C, and D and RESET			0.4	V
		Other outputs	$I_{OL} = 1.4 \text{ mA}$		0.4	
$V_{OH}$	High-level output voltage		$I_{OH} = -50 \mu\text{A}$		$0.9 V_{CC}$	V
			$I_{OH} = -2 \text{ mA}$		2.4	
$I_I$	Input current	MC	$0 \text{ V} \leq V_I \leq 0.3 \text{ V}$		10	$\mu\text{A}$
			$0.3 \text{ V} < V_I < V_{CC} - 0.3$		50	
			$V_{CC} - 0.3 \text{ V} \leq V_I \leq V_{CC} + 0.3 \text{ V}$		10	
			$V_{CC} + 0.3 \text{ V} < V_I \leq 13 \text{ V}$		650	
			$12 \text{ V} \leq V_I \leq 13 \text{ V} \ddagger$		50	mA
		I/O pins	$0 \text{ V} \leq V_I \leq V_{CC}$		$\pm 10$	
$I_{OL}$	Low-level output current	Ports A, B, C, and D and RESET	$V_{OL} = 0.4 \text{ V}$		2	mA
		Other outputs	$V_{OL} = 0.4 \text{ V}$		1.4	
$I_{OH}$	High-level output current		$V_{OH} = 0.9 V_{CC}$		-50	$\mu\text{A}$
			$V_{OH} = 2.4 \text{ V}$		-2	mA
$I_{CC}$	Supply current (Operating mode) Osc Power bit = 0 (see Note 7)	TMS370Cx50, TMS370Cx52	Notes 5 and 6 CLKIN = 20 MHz		45	mA
		TMS370Cx56			56	
		TMS370C850			80	
		TMS370C756			95	
		TMS370Cx50, TMS370Cx52	Notes 5 and 6 CLKIN = 12 MHz		30	
		TMS370Cx56			36	
		TMS370C850			56	
		TMS370C756			70	
		TMS370Cx5x †	Notes 5 and 6 CLKIN = 2 MHz		11	
		TMS370C850			25	
		TMS370C756			40	

† All TMS370Cx5x devices except TMS370C850 and TMS370C756.

‡ Input current  $I_{PP}$  will be of maximum of 50 mA only when programming EPROM.

**Notes:** 5) Single chip mode, ports configured as inputs, or outputs with no load. All inputs  $\leq 0.2 \text{ V}$  or  $\geq V_{CC} - 0.2 \text{ V}$ .

6) XTAL2/CLKIN is driven with an external square wave signal with 50% duty cycle and rise and fall times less than 10 ns. Currents may be higher with a crystal oscillator. At 20 MHz this extra current =  $.01 \text{ mA} \times (\text{total load capacitance} + \text{crystal capacitance in pF})$ .

7) Maximum operating current for TMS370Cx50 and TMS370Cx52 =  $1.9 (\text{CLKIN}) + 7 \text{ mA}$ .  
Maximum operating current for TMS370Cx56 =  $2.5 (\text{CLKIN}) + 5.8 \text{ mA}$ .  
Maximum operating current for TMS370C850 =  $3.06 (\text{CLKIN}) + 19 \text{ mA}$ .

**Table 16–26. Electrical Characteristics over Full Ranges of Recommended Operating Conditions (Concluded)**

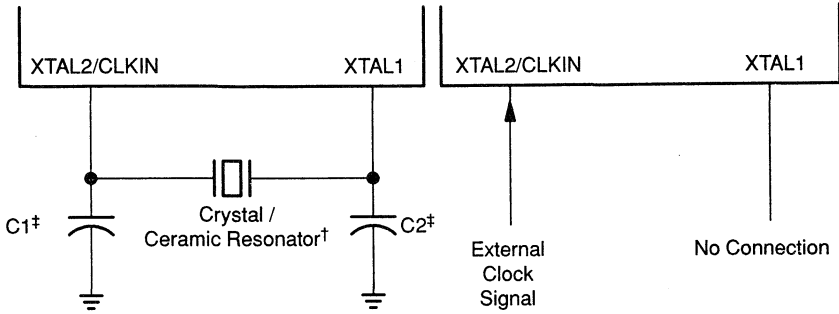
Parameter		Test Conditions	Min	Typ	Max	Unit
$I_{CC}$	Supply current (Standby mode) Osc Power bit = 0 (See Note 8)	TMS370Cx5x †	Notes 5 and 6		17	mA
		TMS370C850	CLKIN = 20 MHz		28	
		TMS370C756			28	
	TMS370Cx5x †	Notes 5 and 6		11		
		TMS370C850	CLKIN = 12 MHz		18	
		TMS370C756			18	
	TMS370Cx5x †	Notes 5 and 6		3.5		
		TMS370C850	CLKIN = 2 MHz		6.0	
		TMS370C756			6.0	
$I_{CC}$	Supply current (Standby mode) Osc Power bit = 1 (See Note 9)	TMS370Cx5x †	Notes 5 and 6 CLKIN = 12 MHz		8.6	mA
			Notes 5 and 6 CLKIN = 2 MHz		3.0	
$I_{CC}$	Supply current (Halt Mode)	TMS370Cx5x †	Note 5		30	$\mu$ A
		TMS370C850	XTAL2/CLKIN < 0.2 V		100	
		TMS370C756			100	

† All TMS370Cx5x devices except TMS370C850 and TMS370C756.

- Notes:**
- Single chip mode, ports configured as inputs, or outputs with no load. All inputs  $\leq 0.2$  V or  $\geq V_{CC} - 0.2$  V.
  - XTAL2/CLKIN is driven with an external square wave signal with 50% duty cycle and rise and fall times less than 10 ns. Currents may be higher with a crystal oscillator. At 20 MHz this extra current =  $.01 \text{ mA} \times (\text{total load capacitance} + \text{crystal capacitance in pF})$ .
  - Maximum operating current for TMS370Cx50 and TMS370Cx52 =  $1.9 (\text{CLKIN}) + 7 \text{ mA}$ .  
Maximum operating current for TMS370Cx56 =  $2.5 (\text{CLKIN}) + 5.8 \text{ mA}$ .  
Maximum operating current for TMS370C850 =  $3.06 (\text{CLKIN}) + 19 \text{ mA}$ .
  - Maximum standby current for TMS370Cx5x =  $0.75 (\text{CLKIN}) + 2 \text{ mA}$ .  
Maximum standby current for TMS370C850 =  $1.2 (\text{CLKIN}) + 3.6 \text{ mA}$ .
  - Maximum standby current for TMS370Cx5x =  $0.56 (\text{CLKIN}) + 1.9 \text{ mA}$ . (Osc power bit valid only from 2 MHz to 12 MHz.)



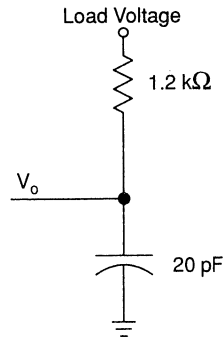
Figure 16–14. Recommended Crystal/Clock Connections



† The crystal/ceramic resonator frequency is four times the reciprocal of the system clock period.

‡ The values of C1 and C2 are typically 15 pF. See manufacturer's recommendations for ceramic resonators.

Figure 16–15. Typical Output Load Circuit §



Case 1:  $V_O = V_{OH} = 2.4 \text{ V}$ ; Load Voltage = 0 V

Case 2:  $V_O = V_{OL} = 0.4 \text{ V}$ ; Load Voltage = 2.8 V for Ports A, B, C, and D, and  $\overline{\text{RESET}}$   
Load Voltage = 2.1 V for other outputs

§ All measurements are made with the pin loading as shown unless otherwise noted. All measurements are made with XTAL2/CLKIN driven by an external square wave signal with a 50% duty cycle and rise and fall times less than 10 ns unless otherwise stated.

### 16.3.1 Timing Parameter Symbology

Timing parameter symbols have been created in accordance with JEDEC Standard 100. In order to shorten the symbols, some of the pin names and other related terminology have been abbreviated as follows:

A	Address	RXD	SCIRXD
AR	Array	S	Slave mode
B	Byte	SCC	SCICLK
CI	XTAL2/CLKIN	SIMO	SPISIMO
CO	CLKOUT	SOMI	SPISOMI
D	Data	SPC	SPICLK
E	$\overline{\text{EDS}}$	W	Write
PGM	Program	WT	$\overline{\text{WAIT}}$
R	Read		

Lowercase subscripts and their meanings are:

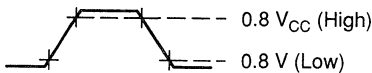
c	cycle time (period)	r	rise time
d	delay time	su	setup time
f	fall time	v	valid time
h	hold time	w	pulse duration (width)

The following additional letters are used with these meanings:

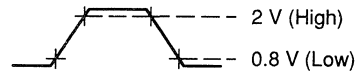
H	High	V	Valid
L	Low	Z	High Impedance

### 16.3.2 Parameter Measurement Information

All timings are measured between high and low measurement points as indicated in the figures below.



**XTAL2/CLKIN Measurement Points**



**General Measurement Points**

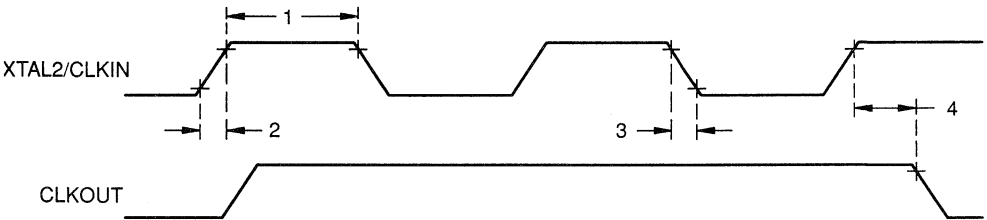
**Table 16–27. External Clocking Requirements**<sup>†</sup>

No.	Parameter	Min	Nom	Max	Unit
1	$t_{w(CI)}$ XTAL2/CLKIN pulse duration (see Note 10)	20			ns
2	$t_{r(CI)}$ XTAL2/CLKIN rise time			30	ns
3	$t_{f(CI)}$ XTAL2/CLKIN fall time			30	ns
4	$t_{d(CIH-COL)}$ Delay time, XTAL2/CLKIN rise to CLKOUT fall			100	ns
	CLKIN Crystal operating frequency	2		20	MHz

<sup>†</sup> For  $V_{IL}$  and  $V_{IH}$ , refer to Recommended Operating Conditions.

**Note 10:** This pulse may be either a high pulse, as illustrated, which extends from the earliest valid high to the final valid high in an XTAL2/CLKIN cycle, or a low pulse, which extends from the earliest valid low to the final valid low in an XTAL2/CLKIN cycle.

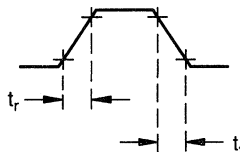
**Figure 16–16. External Clock Timing**



**Table 16–28. Peripheral Module and General Purpose Output Switching Time Requirements**

Parameter		Min	Nom	Max	Unit
$t_r$	Rise time INT2, INT3, SPISOMI, SPISIMO, SPICLK, T1IC/CR, T1PWM, T1EVT, T2IC1/CR, T2IC2/PWM, T2EVT, SCITXD, SCIRXD, SCICLK			45	ns
$t_f$	Fall time INT2, INT3, SPISOMI, SPISIMO, SPICLK, T1IC/CR, T1PWM, T1EVT, T2IC1/CR, T2IC2/PWM, T2EVT, SCITXD, SCIRXD, SCICLK			45	ns

**Figure 16–17. Switching Time Measurement Points**



**Table 16–29. Recommended EPROM Operating Conditions for Programming**

Parameter		Min	Nom	Max	Unit
V <sub>CC</sub>	Supply voltage	4.75		5.5	V
V <sub>PP</sub>	Supply voltage at MC pin	12	12.5	13	V
I <sub>PP</sub>	Supply current at MC pin during programming (V <sub>PP</sub> = 13 V)		30	50	mA
CLKIN	Operating crystal frequency	2		20	MHz

**Table 16–30. Recommended EPROM Timing Requirements for Programming**

Parameter		Min	Nom	Max	Unit
t <sub>w(IEPGM)</sub>	Initial programming duration (see Note 11)	0.95	1	1.05	ms
t <sub>w(FEPGM)</sub>	Final programming duration	2.85		78.75	ms

**Note 11:** Programming signal is active when both EXE (EPCTL.0) and VPPS (EPCTL.6) are set.

**Table 16–31. Recommended EEPROM Timing Requirements for Programming**

Parameter		Min	Nom	Max	Unit
t <sub>w(PGM)B</sub>	Programming duration to insure valid data is stored (byte mode)	10			ms
t <sub>w(PGM)AR</sub>	Programming duration to insure valid data is stored (array mode)	20			ms

**Table 16–32. Switching Characteristics and Timing Requirements<sup>†</sup>**

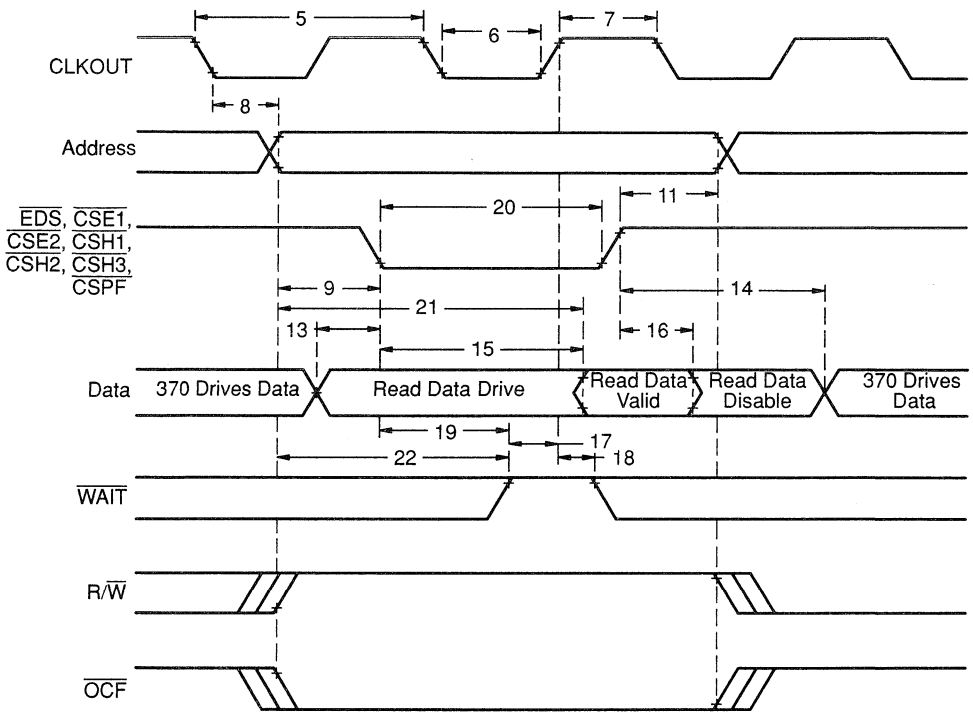
No.	Parameter	Min	Max	Unit
5	$t_c$ CLKOUT (system clock) cycle time	200	2000	ns
6	$t_{w(COL)}$ CLKOUT low pulse duration	$0.5t_c - 20$	$0.5t_c$	ns
7	$t_{w(COH)}$ CLKOUT high pulse duration	$0.5t_c$	$0.5t_c + 20$	ns
8	$t_{d(COL-A)}$ Delay time, CLKOUT low to address R/W, and $\overline{OCF}$ valid		$0.25t_c + 40$	ns
9	$t_{v(A)}$ Address valid to $\overline{EDS}$ , CSE1, CSE2, CSH1, CSH2, CSH3, and CSPF low	$0.5t_c - 50$		ns
10	$t_{su(D)}$ Write data setup time to $\overline{EDS}$ high	$0.75t_c - 40^*$		ns
11	$t_{h(EH-A)}$ Address, R/W, and $\overline{OCF}$ hold time from $\overline{EDS}$ , CSE1, CSE2, CSH1, CSH2, CSH3, and CSPF high	$0.5t_c - 40$		ns
12	$t_{h(EH-D)W}$ Write data hold time from $\overline{EDS}$ high	$0.75t_c + 15$		ns
13	$t_{d(DZ-EL)}$ Delay time, data bus high impedance to $\overline{EDS}$ low (read cycle)	$0.25t_c - 30$		ns
14	$t_{d(EH-D)}$ Delay time, $\overline{EDS}$ high to data bus enable (read cycle)	$1.25t_c - 40$		ns
15	$t_{d(EL-DV)}$ Delay time, $\overline{EDS}$ low to read data valid		$t_c - 65^*$	ns
16	$t_{h(EH-D)R}$ Read data hold time from $\overline{EDS}$ high	0		ns
17	$t_{su(WT-COH)}$ $\overline{WAIT}$ setup time to CLKOUT high	$0.25t_c + 75^{**}$		ns
18	$t_{h(COH-WT)}$ $\overline{WAIT}$ hold time from CLKOUT high	0		ns
19	$t_{d(ED-WTV)}$ Delay time, $\overline{EDS}$ low to $\overline{WAIT}$ valid		$0.5t_c - 70$	ns
20	$t_w$ Pulse duration, $\overline{EDS}$ , CSE1, CSE2, CSH1, CSH2, CSH3, and CSPF low	$t_c - 40^*$	$t_c + 40^*$	ns
21	$t_{d(AV-DV)R}$ Delay time, address valid to read data valid		$1.5t_c - 75^*$	ns
22	$t_{d(AV-WTV)}$ Delay time, address valid to $\overline{WAIT}$ valid		$t_c - 85$	ns
23	$t_{d(AV-EH)}$ Delay time, address valid to $\overline{EDS}$ high (end of write)	$1.5t_c - 40^*$		ns

<sup>†</sup>  $t_c$  = system clock cycle time = 4/CLKIN

\* If wait states, PFWait, or the Auto-Wait feature are used, add  $t_c$  to this value for each wait state invoked.

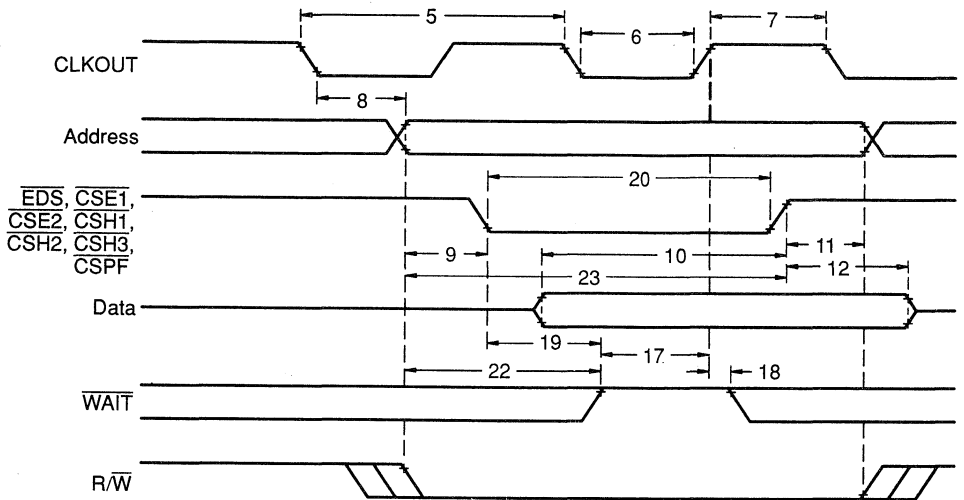
\*\* If the Auto-Wait feature is enabled, the  $\overline{WAIT}$  input may assume a "Don't Care" condition until the third cycle of the access. The  $\overline{WAIT}$  signal needs to be synchronized with the high pulse of the CLKOUT signal while still observing the minimum setup time.

Figure 16–18. External Read Timing



16

Figure 16–19. External Write Timing



16

**Table 16–33. SPI Master External Timing Characteristics** †

No.	Parameter	Min	Max	Unit
38	$t_{c(SPC)}$ SPICLK cycle time	$2t_c$	$256t_c$	ns
39	$t_{w(SPCL)}$ SPICLK low pulse duration	$t_c - 45$	$0.5t_{c(SPC)} + 45$	ns
40	$t_{w(SPCH)}$ SPICLK high pulse duration	$t_c - 45$	$0.5t_{c(SPC)} + 45$	ns
41	$t_{d(SPCL-SIMOV)}$ Delay time, SPISIMO valid after SPICLK low (Polarity = 1)	- 50	50	ns
42	$t_{v(SPCH-SIMO)}$ SPISIMO data valid after SPICLK high (Polarity = 1).	$t_{w(SPCH)} - 50$		ns

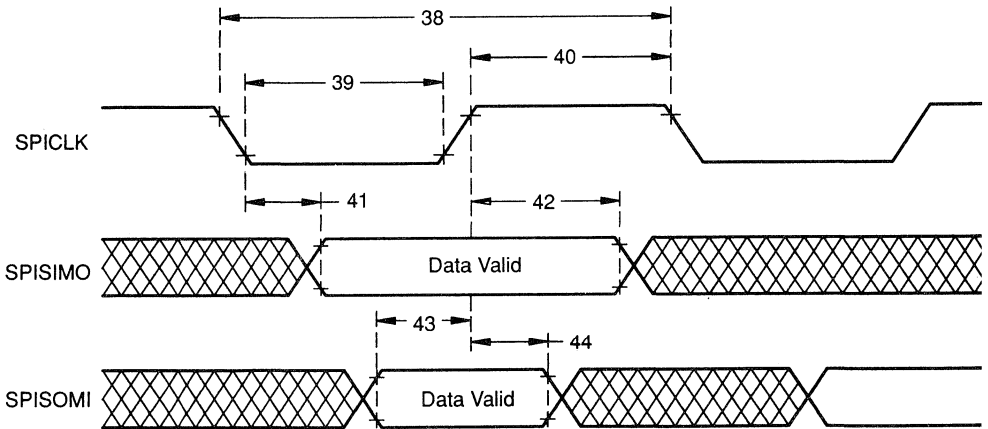
16

**Table 16–34. SPI Master External Timing Requirements** †

No.	Parameter	Min	Max	Unit
43	$t_{su(SOMI-SPCH)}$ SPISOMI setup time to SPICLK high (Polarity = 1)	$0.25t_c + 150$		ns
44	$t_{v(SPCH-SOMI)}$ SPISOMI data valid after SPICLK high (Polarity = 1)	0		ns

†  $t_c$  = system clock cycle time = 4/CLKIN.

**Figure 16–20. SPI Master External Timing**



**Note:** The diagram above is for Polarity = 1. SPICLK is inverted from above diagram when Polarity = 0.



**Table 16–35. SPI Slave External Timing Characteristics**<sup>†</sup>

No.	Parameter	Min	Max	Unit
48	$t_{d(SPCL-SOMIV)S}$ Delay time, SPISOMI valid after SPICLK low (Polarity = 1)		$3.25t_c + 125$	ns
49	$t_{v(SPCH-SOMI)S}$ SPISOMI data valid after SPICLK high (Polarity = 1)	$t_{w(SPCH)S}$		ns

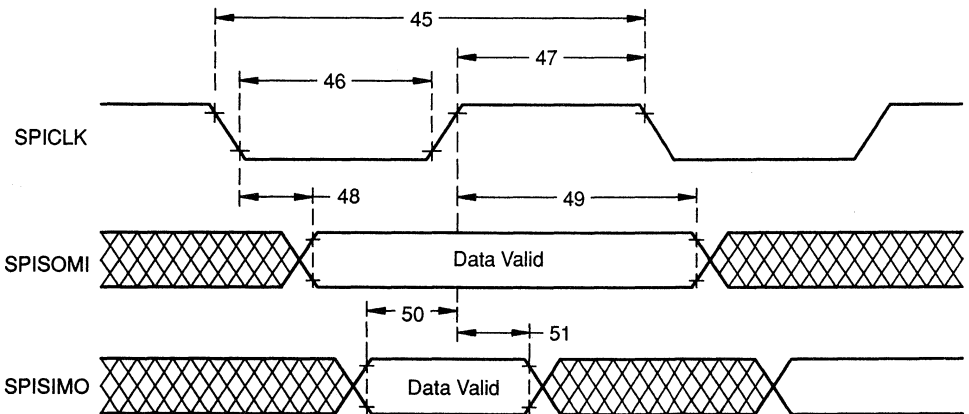
**Table 16–36. SPI Slave External Timing Requirements**<sup>†</sup>

No.	Parameter	Min	Max	Unit
45	$t_{c(SPC)S}$ SPICLK cycle time	$8t_c$		ns
46	$t_{w(SPCL)S}$ SPICLK low pulse duration	$4t_c - 45$	$0.5t_{c(SPC)S} + 45$	ns
47	$t_{w(SPCH)S}$ SPICLK high pulse duration	$4t_c - 45$	$0.5t_{c(SPC)S} + 45$	ns
50	$t_{su(SIMO-SPCH)S}$ SPISIMO setup time to SPICLK high (Polarity = 1)	0		ns
51	$t_{v(SPCH-SIMO)S}$ SPISIMO data valid after SPICLK high (Polarity = 1)	$3t_c + 100$		ns

16

<sup>†</sup>  $t_c$  = system clock cycle time = 4/CLKIN.

**Figure 16–21. SPI Slave External Timing**



- Notes:**
- 1) The diagram above is for Polarity = 1. SPICLK is inverted from above diagram when Polarity = 0.
  - 2) As a slave, the SPICLK pin is used as the input for the serial clock, which is supplied from the network master.

**Table 16–37. SCI Isosynchronous Mode Timing Characteristics for Internal Clock †**

No.	Parameter	Min	Max	Unit
24	$t_{c(SCC)}$ SCICLK cycle time	$2t_c$	$131,072t_c$	ns
25	$t_w(SCCL)$ SCICLK low pulse duration	$t_c - 45$	$0.5t_{c(SCC)} + 45$	ns
26	$t_w(SCCH)$ SCICLK high pulse duration	$t_c - 45$	$0.5t_{c(SCC)} + 45$	ns
27	$t_d(SCCL-TXDV)$ Delay time, SCITXD valid after SCICLK low	- 50	50	ns
28	$t_v(SCCH-TXD)$ SCITXD data valid after SCICLK high	$t_w(SCCH) - 50$		ns

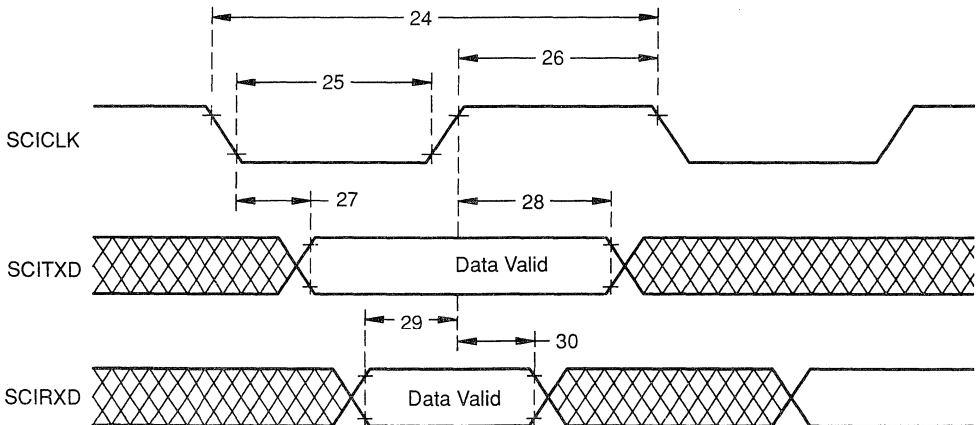
16

**Table 16–38. SCI Isosynchronous Mode Timing Requirements for Internal Clock †**

No.	Parameter	Min	Max	Unit
29	$t_{su}(RXD-SCCH)$ SCIRXD setup time to SCICLK high	$0.25t_c + 145$		ns
30	$t_v(SCCH-RXD)$ SCIRXD data valid after SCICLK high	0		ns

†  $t_c$  = system clock cycle time =  $4/CLKIN$ .

**Figure 16–22. SCI Isosynchronous Mode Timing Diagram for Internal Clock**



**Table 16–39. SCI Isosynchronous Mode Timing Characteristics for External Clock †**

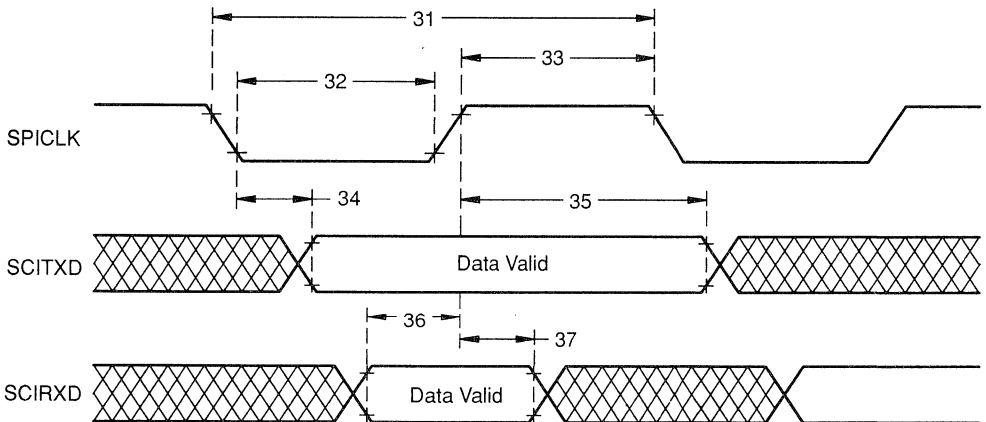
No.	Parameter	Min	Max	Unit
34	$t_{d(SCCL-TXD)}$ Delay time, SCITXD valid after SCICLK low		$4.25t_c + 145$	ns
35	$t_{v(SCCH-TXD)}$ SCITXD data valid after SCICLK high	$t_{w(SCCH)}$		ns

**Table 16–40. SCI Isosynchronous Mode Timing Requirements for External Clock †**

No.	Parameter	Min	Max	Unit
31	$t_c(SCC)$ SCICLK cycle time	$10t_c$		ns
32	$t_{w(SCCL)}$ SCICLK low pulse duration	$4.25t_c + 120$		ns
33	$t_{w(SCCH)}$ SCICLK high pulse duration	$t_c + 120$		ns
36	$t_{su}(RXD-SCCH)$ SCIRXD setup time to SCICLK high	40		ns
37	$t_{v}(SCCH-RXD)$ SCIRXD data valid after SCICLK high	$2t_c$		ns

†  $t_c$  = system clock cycle time = 4/CLKIN.

**Figure 16–23. SCI Isosynchronous Mode Timing Diagram for External Clock**



### 16.3.3 A/D Converter

The A/D Converter has a separate power bus for its analog circuitry. These pins are referred to as  $V_{CC3}$  and  $V_{SS3}$ . The purpose is to enhance A/D performance by preventing digital switching noise of the logic circuitry which may be present on  $V_{SS}$  and  $V_{CC}$  from coupling into the A/D analog stage. All A/D specifications will be given with respect to  $V_{SS3}$  unless otherwise noted.

Resolution ..... 8 bits (256 values)

Monotonic ..... Yes

Output conversion code ... 00h to FFh (00 for  $V_I \leq V_{SS3}$ ; FF for  $V_I \geq V_{ref}$ )

Conversion time (excluding sample time) .....  $164t_c$

16

**Table 16–41. Recommended Operating Conditions**

		Min	Nom	Max	Unit
$V_{CC3}$	Analog supply voltage	4.5	5	5.5	V
		$V_{CC} - 0.3$		$V_{CC} + 0.3$	
$V_{SS3}$	Analog ground	$V_{SS} - 0.3$		$V_{SS} + 0.3$	V
$V_{ref}$	Non- $V_{CC3}$ reference (See Note 12)	2.5	$V_{CC3}$	$V_{CC3} + 0.1$	V
	Analog input for conversion	$V_{SS3}$		$V_{ref}$	V

**Note 12:**  $V_{ref}$  must be stable, within  $\pm 1/2$  LSB of the required resolution, during the entire conversion time.

**Table 16–42. A/D Converter Operating Characteristics over Full Range of Operating Conditions**

Parameter	Test Conditions	Min	Typ	Max	Unit
Absolute accuracy (See Note 13)	$V_{CC3} = 5.5 \text{ V}, V_{ref} = 5.1 \text{ V}$			$\pm 1$	LSB
Differential/integral linearity error (See Notes 13 and 14)	$V_{CC3} = 5.5 \text{ V}, V_{ref} = 5.1 \text{ V}$			$\pm 0.5$	LSB
$I_{CC3}$ Analog supply current	Converting			2	mA
	Non-Converting			5	$\mu\text{A}$
$I_I$ Input current, AN0–AN7	$0 \text{ V} \leq V_I \leq 5.5 \text{ V}$			2	$\mu\text{A}$
$I_{Vref}$ Vref input charge current				1	mA
$Z_{ref}$ Source impedance of $V_{ref}$	$\text{XTAL2/CLKIN} \leq 12 \text{ MHz}$			24	$\text{k}\Omega$
	$12 \text{ MHz} < \text{XTAL2/CLKIN} \leq 20 \text{ MHz}$			10	$\text{k}\Omega$

16

- Notes:** 13) Absolute resolution = 20 mV. At  $V_{ref} = 5 \text{ V}$ , this is 1 LSB. As  $V_{ref}$  decreases, LSB size decreases and thus absolute accuracy and differential/integral linearity errors in terms of LSBs increases.
- 14) Excluding quantization error of 1/2 LSB.

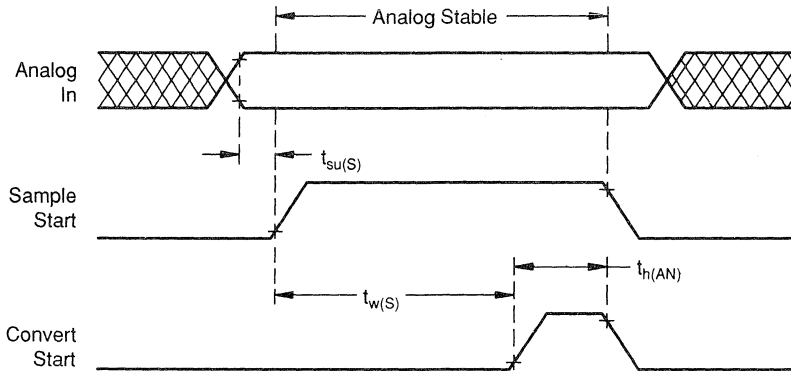
The A/D module allows complete freedom in design of the sources for the analog inputs. The period of the sample time is user-defined such that high impedance sources can be accommodated without penalty to low-impedance sources. The sample period begins when the SAMPLE START bit of the A/D Control Register (ADCTL) is set to 1. The end of the signal sample period occurs when the conversion bit (CONVERT START) of the ADCTL is set to 1. After a hold time, the converter will reset the SAMPLE START and CONVERT START bits, signaling that a conversion has started and the analog signal can be removed.

**Table 16–43. Analog Timing Requirements**

Parameter		Min	Nom	Max	Unit
$t_{su(S)}$	Analog input setup to sample command	0			ns
$t_{h(AN)}$	Analog input hold from start of conversion	$18t_c$			ns
$t_w(S)$	Duration of sample time per kilohm of source impedance (see Note 15)	1			$\mu\text{s}/\text{k}\Omega$

**Note 15:** The value given is valid for a signal with a source impedance greater than  $1\text{ k}\Omega$ . If the source impedance is less than  $1\text{ k}\Omega$ , use a minimum sampling time of  $1\text{ }\mu\text{s}$ .

**16** Figure 16–24. Analog Timing



Introduction	1
Assembly Language Instruction Set	13
TMS370 Family Devices	2
Design Aids	14
CPU and Memory Organization	3
Development Support	15
System and Digital I/O Configuration	4
Electrical Specifications	16
Interrupts and System Reset	5
Customer Information	17
EEPROM Modules	6
Appendices	A-H
Timer 1 Module	7
Timer 2 Module	8
Serial Communications Interface (SCI) Port	9
Serial Peripheral Interface (SPI) Module	10
Analog-to-Digital Converter Module	11
TMS370 Programmable Acquisition and Control Timer	12





## Customer Information

---

---

---

---

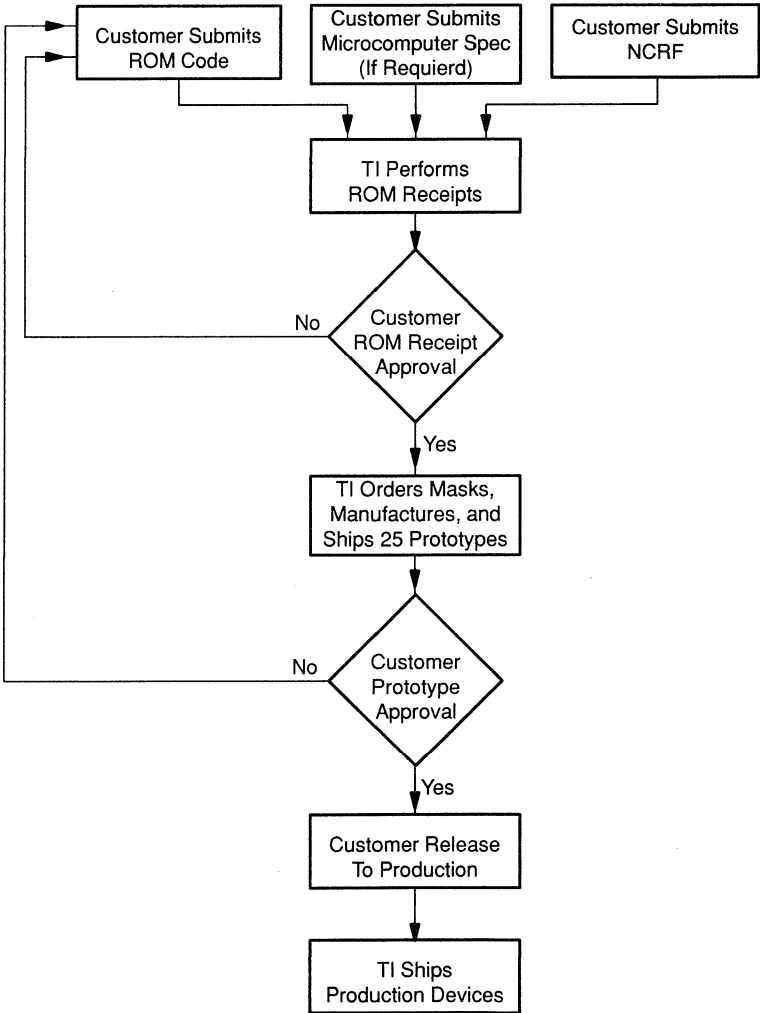
This chapter includes general information on mask-ROM prototyping, TMS370 physical characteristics, and parts ordering. Topics covered in this chapter include:

<b>Section</b>	<b>Page</b>
17.1 Mask ROM Prototype and Production Flow .....	17-2
17.2 Mechanical Package Information .....	17-6
17.3 TMS370 Family Numbering and Symbol Conventions .....	17-10
17.4 Development Support Tools Ordering Information .....	17-15

### 17.1 Mask ROM Prototype and Production Flow

The TMS370 family includes many mask-ROM microcontrollers. The ROM is manufactured containing customer's application code. The custom-programmed nature of these devices requires a standard, defined interface between the customer and the factory during production. Figure 17-1 shows this standard of prototype/production flow for customer ROM receipt.

Figure 17-1. Prototype and Production Flow



17

1) Customer Required Information

For TI to accept the receipt of a customer ROM algorithm, each of the following three items must be received by the TI factory:

- a) The customer completes and submits a New Code Release Form (NCRF - available from TI Field Sales Office) describing the custom features of the device (e.g., customer information, prototype and production quantities and dates, any exceptions to standard electrical specifications, customer part numbers and symbols, package type, etc.).
- b) If non-standard specifications are requested on the NCRF, the customer submits a copy of the description of the microcomputer, including the functional description and electrical specification (including absolute maximum ratings, recommended operating conditions, and timing values). TI will then respond to the requested specification changes.
- c) When the customer has completed code development and has verified the code with the development system, the object file is submitted in **Intel hex object format** to the TI factory using an acceptable transfer media. Acceptable media include the following:
  - Modem transfer: PC-to-PC via Xmodem, Ymodem, or Zmodem protocol or Microstuf's Crosstalk XVI protocol.
  - MS-DOS formatted 5 1/4" floppy disk compatible with IBM compatible PC.
  - EPROM devices (currently supported: TMS2764, TMS27C64, TMS27128, TMS27C128).
  - TMS370C8xx or TMS370C7xx FFE devices.

The completed NCRF, customer specification (if required), and ROM code should be given to the local representative or sent to the nearest Field Sales Office.

2) TI Performs ROM Receipt

Code review and ROM receipt is performed on the customer's code and a unique manufacturing ROM code number (such as R1501234FN) is assigned to the customer's algorithm. All future correspondence should indicate this number. The ROM receipt procedure reads the ROM code information, processes it, reproduces the customer's ROM object code on the media requested on the NCRF, and returns the processed and the original code to the customer for verification of correct ROM receipt. (Note: The customer must provide the EPROM/EEPROM device if that type of media has been requested on the NCRF). All TMS370 mask ROM devices contain ROM space that is reserved for TI use only. The contents of this reserved space is changed when TI processes the mask ROM with the customer's object code. Therefore, the customer should not use locations 7FE0h through 7FEBh in their algorithm or checksum routine.

Data EEPROM locations are not programmed in the standard production flow.

3) Customer ROM Receipt Approval

The customer then verifies that the ROM code received and processed by TI is correct and that no information was misinterpreted in the transfer. The customer must then return an algorithm approval form (available from the field sales office) for correct ROM receipt verification or re-submit the code for processing. This written confirmation of verification constitutes the contractual agreement for creation of the custom mask and manufacture of ROM verification prototype units.

4) TI Orders Masks, Manufacturing, and Ships 25 Prototypes

TI generates the prototype photomasks, processes, manufactures, and tests 25 microcomputer prototypes containing the customer's ROM pattern for shipment to the customer for ROM code verification. These microcomputer devices have been made using the custom mask but are for the purposes of ROM verification only. Prototype devices are symbolized with a **P** preceding the manufacturing ROM code number (e.g., PR1501234FN) to differentiate them from production devices.

5) Customer Prototype Approval

The customer verifies the operation of these prototypes in the system and responds with written customer prototype approval or disapproval. This written customer prototype approval constitutes the contractual agreement to initiate volume microcomputer production using the verified prototype ROM code.

6) Customer Release to Production

With customer algorithm approval, the ROM code is released to production and TI will begin shipment of production devices according to customer's final specification and order requirements.

Two lead times are quoted in reference to the preceding flow:

- Prototype lead time — elapsed time from the receipt of written ROM receipt verification to the delivery of 25 prototype devices.
- Production lead time — elapsed time from the receipt of written customer prototype approval to delivery of production devices.

For the latest TMS370 family lead times, contact the nearest TI field sales office.

**Note:**

All TMS370 family devices contain mask ROM space reserved for TI use only. This space includes locations 7FE0h through 7FEBh. This reserved area should therefore not be used in the customer's software algorithm, nor should it be used during mask ROM/firmware development. **The reserved location contents are changed by TI.**

## 17.2 Mechanical Package Information

The TMS370 microcomputer family devices are assembled in three package types according to the type of material and outline used for the package. These package types are:

- ❑ Plastic dual-inline package (DIP)
- ❑ Plastic leaded chip carrier (PLCC)
- ❑ Ceramic leaded chip carrier (CLCC)

Package types are designated in the device symbol by the suffix on the customer's ROM code number for devices manufactured with customer ROM code (e.g., R1501234FN) and by the suffix of the standard device number for devices with EEPROM. Table 17–1 indicates the package type, suffix indicator, and family members supported on that package type.

17

**Table 17–1. Package Types**

Package Type	Suffix Indicator	Family Members
28-pin plastic DIP (100-mil pin spacing)	N	TMS370Cx1x
28-pin PLCC (50-mil pin spacing)	FN	TMS370Cx1x
44-pin PLCC (50-mil pin spacing)	FN	TMS370Cx3x
44-pin CLCC	FJ	TMS370C73x
68-pin PLCC (50-mil pin spacing)	FN	TMS370Cx5x
68-pin CLCC	FJ	TMS370C75x

**Figure 17-2. 28-Pin Plastic Dual-Inline Package, 100-MIL Pin Spacing (Type N Package Suffix)**

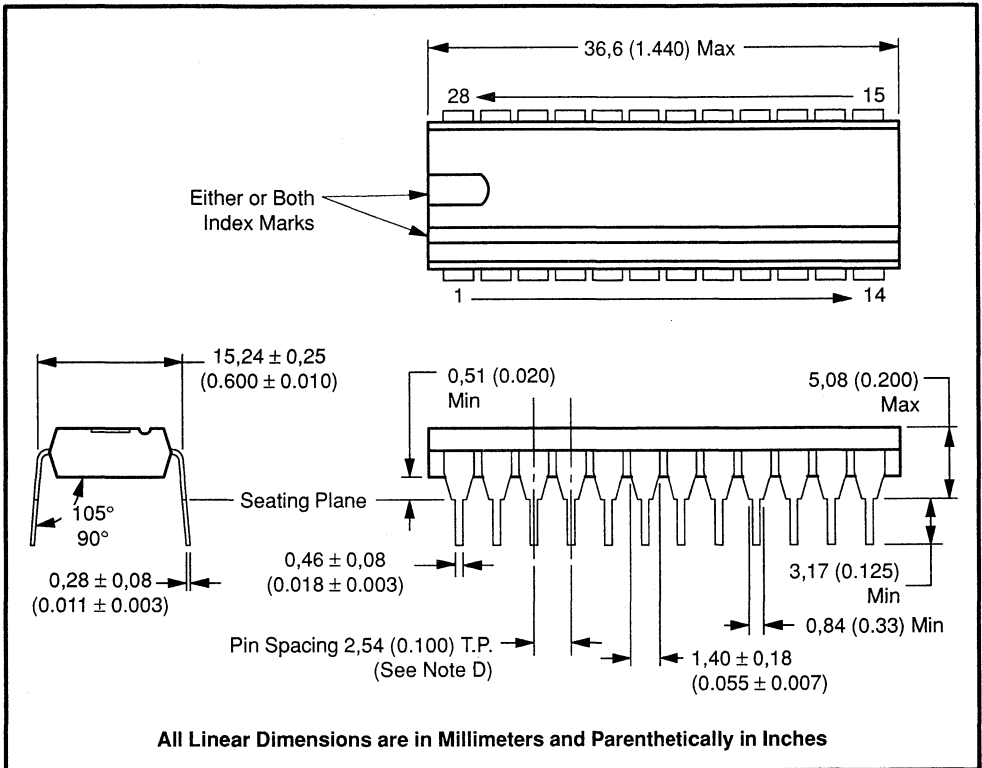
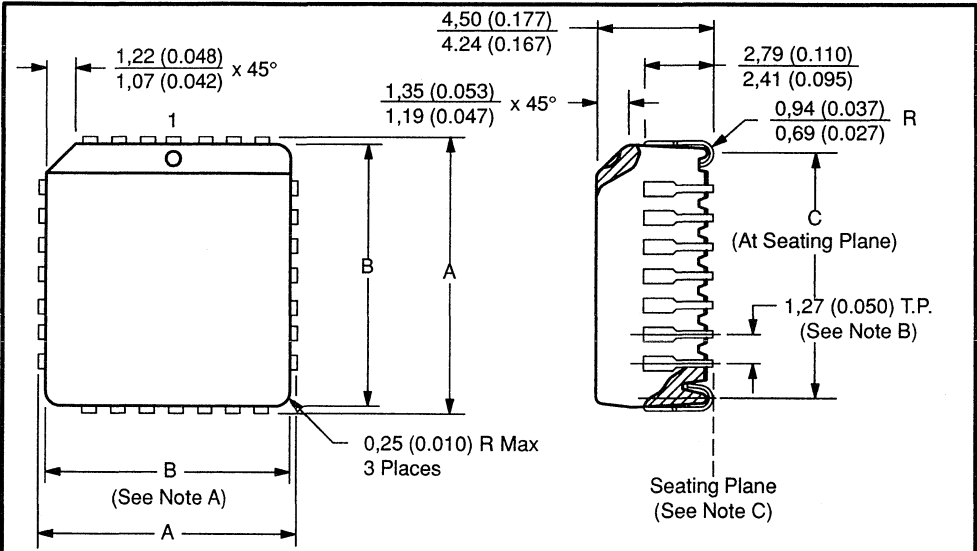
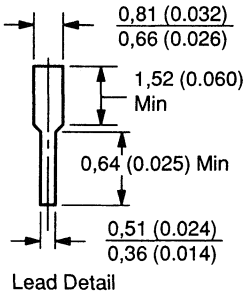


Figure 17-3. Plastic-Leaded Chip Carrier Package (Type FN Package Suffix)



17

JEDEC OUTLINE	NO. OF PINS	A		B		C	
		MIN	MAX	MIN	MAX	MIN	MAX
MO-047AA	20	9,78 (0.385)	10,03 (0.395)	8,89 (0.350)	9,04 (0.356)	7,87 (0.310)	8,38 (0.330)
MO-047AB	28	12,32 (0.485)	12,57 (0.495)	11,43 (0.450)	11,58 (0.456)	10,41 (0.410)	10,92 (0.430)
MO-047AC	44	17,40 (0.685)	17,65 (0.695)	16,51 (0.650)	16,66 (0.656)	15,49 (0.610)	16,00 (0.630)
MO-047AE	68	25,02 (0.985)	25,27 (0.995)	24,13 (0.950)	24,33 (0.956)	23,11 (0.910)	23,62 (0.930)
MO-047AF	84	30,10 (1.185)	30,35 (1.195)	29,21 (1.150)	29,41 (1.158)	27,69 (1.090)	28,70 (1.130)

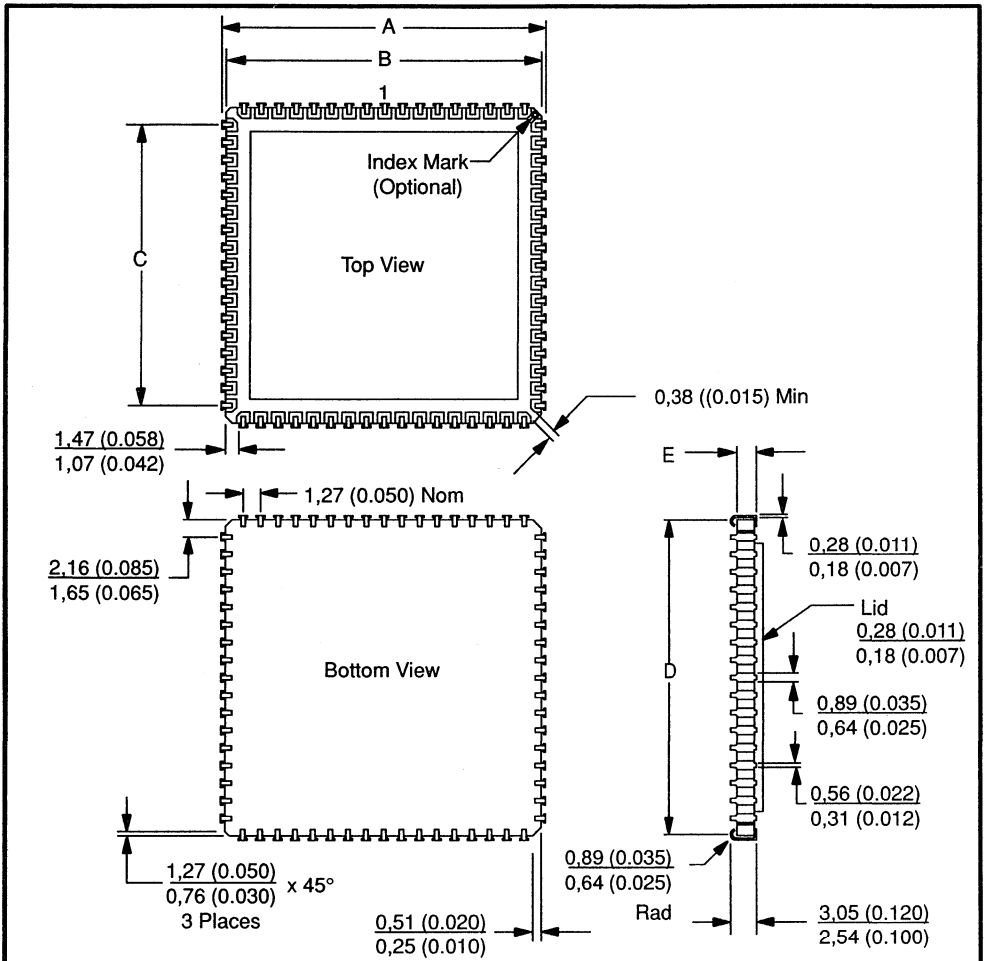


All dimensions and notes to the specified JEDEC outline apply  
 All Linear Dimensions are in Millimeters and Parenthetically in Inches

- Notes:
- A) Centerline of center pin each side is within 0,10 (0.004) of package centerline as determined by dimension B.
  - B) Location of each pin is within 0,127 (0.005) of true position with respect to center pin on each side.
  - C) The lead contact points are planar within 0,10 (0.004).
  - D) The 20-pin and 84-pin packages are not currently offered in the TMS370 family.



Figure 17-4. Ceramic Leaded Chip Carrier Package (FJ Suffix)



17

Pins	Dim	A		B		C		D		E	
		MIN	MAX	MIN	MAX	MIN	MAX	MIN	MAX	MIN	MAX
44		17,27 (0.680)	17,78 (0.700)	16,28 (0.641)	16,74 (0.659)	12,57 (0.495)	12,88 (0.507)	15,49 (0.610)	16,51 (0.650)	1,91 (0.075)	2,16 (0.085)
68		24,89 (0.980)	25,40 (0.100)	23,88 (0.940)	24,51 (0.965)	20,19 (0.795)	20,52 (0.808)	23,11 (0.910)	24,13 (0.950)	1,91 (0.075)	2,41 (0.095)

All Linear Dimensions are in Millimeters and Parenthetically in Inches

## 17.3 TMS370 Family Numbering and Symbol Conventions

All TMS370 devices are marked with information as to the type, package, copyright date(s), place of manufacture, and manufacturing data.

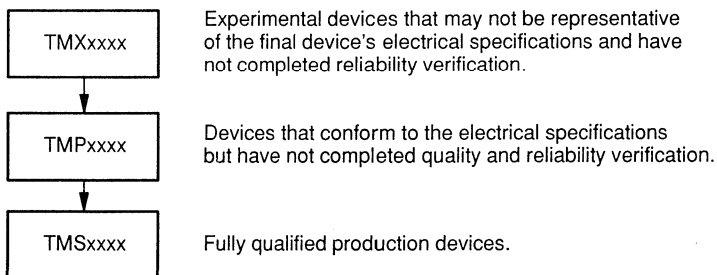
### 17.3.1 Device Prefix Designators

To provide expeditious system evaluations by customers during the product development cycle, Texas Instruments assigns a prefix designator with three options: TMX, TMP, and TMS.

TMX, TMP, and TMS are representative of the evolutionary stages of product development from engineering prototypes through fully qualified production devices. Figure 17–5 depicts this evolutionary development flowchart. Production devices shipped by Texas Instruments have the TMS designator signifying that they have demonstrated the high standards of Texas Instruments quality and reliability.

17

**Figure 17–5. Development Flowchart**



TMX devices are shipped against the following disclaimer:

- 1) Experimental product and its reliability has not been characterized.
- 2) Product is sold "as is".
- 3) Product is not warranted to be exemplary of final production version if or when released by Texas Instruments.

TMP devices are shipped against the following disclaimer:

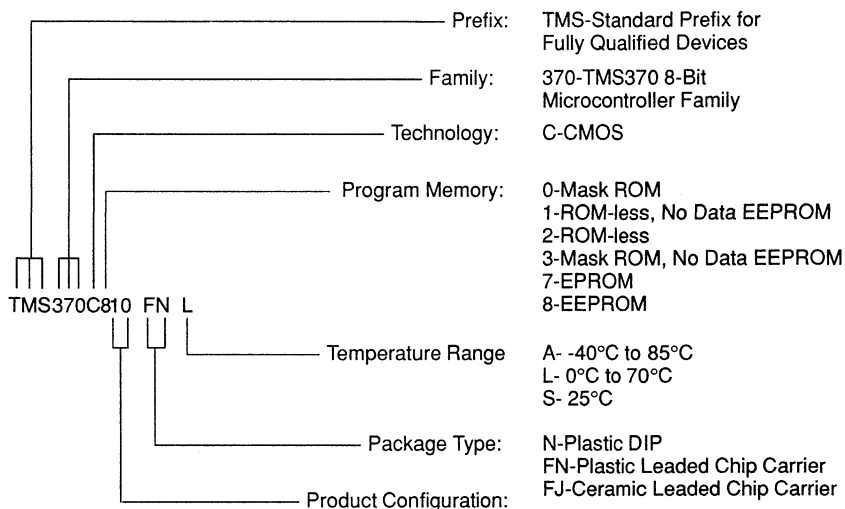
- 1) Customer understands that the product purchased hereunder has not been fully characterized and the expectation of reliability cannot be defined; therefore, Texas Instruments standard warranty refers only to the device's specifications.
- 2) No warranty of merchantability or fitness is expressed or implied.

TMS devices have been fully characterized and the quality and reliability of the device has been fully demonstrated. Texas Instruments' standard warranty applies.

## 17.3.2 Device Numbering Convention

Figure 17–6 illustrates the numbering and symbol nomenclature for the TMS370 family.

**Figure 17–6. TMS370 Family Nomenclature**



17


## 17.3.3 Device Symbols

The device symbolization of the TMS370 family members can be divided into two categories: those with factory programmed mask ROM, and those with user programmed memory.

### 17.3.3.1 TMS370 Family Members with Mask-ROM


TMS370 family members with mask-ROM are custom-programmed devices where the ROM is mask programmed according to the customer's application code. These devices follow the prototyping and production flow outlined in Section 17.1. Since they are semi-custom devices, they receive a unique ROM code identification number.

**Figure 17–7. TI Standard Symbolization for Mask ROM Device in 28-Pin N-Type Package**

Line 1: (a)  (b) 12345678901  
 Line 2: (c) R1X00XXFN  
 Line 3: (d) FRSYYWW  
 Line 4: (e) ©1988TI (f) ©1989TI  
 Line 5: (g) 12345678 (h) Philippines


Key:  
 (a) Texas Instruments Trademark  
 (b) Optional customer part number  
 (c) Customer's ROM code and package type  
 (d) Tracking mark and date code  
 (e) TI microcode copyright  
 (f) Copyright of ROM code  
 (g) Lot code  
 (h) Assembly site

**Figure 17–8. TI Standard Symbolization for Mask ROM Device in 28-Pin FN Type Package**

Line 1: (a) 12345678901  
 Line 2: (b) R1X00XXFN  
 Line 3: (c)  (d) FRSYYWW  
 Line 4:  
 Line 5: (e) 12345678  
 Line 6: (f) ©1988TI  
 (Backside) (g) Philippines


Key:  
 (a) Optional customer part number  
 (b) Customer's ROM code and package type  
 (c) Texas Instruments Trademark  
 (d) Tracking mark and date code  
 (e) Lot code  
 (f) TI microcode copyright  
 (g) Assembly site (bottom of package)

**Figure 17–9. TI Standard Symbolization for Mask ROM Device in 44-Pin FN Type Package**

Line 1: (a) 12345678901  
 Line 2: (b) R1X00XXFN  
 Line 3: (c)  (d) FRSYYWW  
 Line 4: (e) 12345678  
 Line 5: (f) ©1988TI  
 (Backside) (g) Philippines

Key:  
 (a) Optional customer part number  
 (b) Customer's ROM code and package type  
 (c) Texas Instruments Trademark  
 (d) Tracking mark and date code  
 (e) Lot code  
 (f) TI microcode copyright  
 (g) Assembly site (bottom of package)

**Figure 17–10. TI Standard Symbolization for Mask ROM Device in 68-Pin FN Type Package**


Line 1: (a) 12345678901  
 Line 2: (b) R1X00XXFN  
 Line 3: (c)  (d) FRSYYWW  
 Line 4: (e) 12345678  
 Line 5: (f) ©1988TI (g) ©1989TI  
 (Backside) (h) Philippines

Key:  
 (a) Optional customer part number  
 (b) Customer's ROM code and package type  
 (c) Texas Instruments Trademark  
 (d) Tracking mark and date code  
 (e) Lot code  
 (f) TI microcode copyright  
 (g) Copyright of ROM code  
 (h) Assembly site (bottom of package)


### 17.3.3.2 TMS370 Family Members with Program EEPROM

TMS370 family members with on-chip program EEPROM are standard device types, and therefore have a standard identification. The TMS370 family members with program EEPROM include the TMS370C8xx.

**Figure 17–11. TI Standard Symbolization for Program EEPROM Device in N-Type Package**

Line 1:		(b) TMS370C810N	Key:
Line 2:	(a) 	(c) FRSYYWW	(a) Texas Instruments Trademark
Line 3:		(d) ©1988TI	(b) Standard device part number
Line 4:	(e) 12345678	(f) Philippines	(c) Tracking mark and date code
			(d) TI microcode copyright
			(e) Lot code
			(f) Assembly site

**Figure 17–12. TI Standard Symbolization for EEPROM Device in FN-Type Package**

Line 1:	(a) TMS370C850FN	Key:
Line 2:	(b) 	(a) Standard device part number
Line 3:	(c) FRSYYWW	(b) Texas Instruments Trademark
Line 4:	(d) 12345678	(c) Tracking mark and date code
Line 4:	(e) ©1988TI	(d) Lot code
(Backside)	(f) Philippines	(e) TI microcode copyright
		(f) Assembly site (bottom of package)

### 17.3.3.3 TMS370 Family Members with Program EPROM

TMS370 family members with on-chip program EPROM are standard device types, and therefore have a standard identification. The TMS370 family members with program EPROM include the TMS370C7xx.

**Figure 17–13. TI Standard Symbolization for Program EPROM Device in FJ-Type Package (68-Pin and 44-Pin)**

Line 1: (a) TMS370C756FJS

Line 2: (b)  (c) 12345678

Line 3: (d) FRSYYWW

Line 4: (e) ©1988TI

Line 5: (f) Philippines

Key:

(a) Standard device part number

(b) Texas Instruments Trademark

(c) Lot code

(d) Tracking mark and date code

(e) TI microcode copyright

(f) Assembly site (bottom of package)

**17**

**Note:** All symbolization is on backside of package.

## 17.4 Development Support Tools Ordering Information

All the necessary development support tools (excluding a PC) for the TMS370 family are available from TI separately or as a complete package. The development tools are designed to work with an IBM compatible PC with a minimum of 512 K bytes of memory and a 5 1/4 inch floppy disk drive.

### 17.4.1 TMS370 Macro Assembler, Linker, and Utilities

This software package includes all the utilities required for developing object code for the TMS370 devices.

Part Number	Description
TMDS3740810-02	Assembler/Linker (DOS)
TMDS3740210-08	Assembler/Linker (VMS)

### 17.4.2 TMS370 Design Kit

The TMS370 Design Kit contains the necessary software and hardware for a user to evaluate TMS370Cx1x and TMS370Cx5x parts.

Part Number	Description
TMDS3770110	TMS370 Design Kit

### 17.4.3 TMS370 EEPROM Programmer

The TMS370 EEPROM Programmer provides the physical means to program the TMS370 prototype devices. The programmer comes with the necessary cables and control software for interfacing with an IBM compatible PC.

Part Number	Description
TMDS3760510	EEPROM Programmer

### 17.4.4 TMS370 XDS Systems

The XDS system provides software debugging and overall evaluation of a TMS370-based system. The XDS comes complete with necessary cables and debugging program.

Part Number	Description
TMDS3770110	XDS/11 system, 28-pin
TMDS3770111	XDS/11 system, 68-pin
TMDS3762210	XDS/22 system
TMDS3762211	XDS/22 system with PACT

### **17.4.5 Complete TMS370 Development System**

The components above (Assembler/Linker, EEPROM Programmer, and XDS/22 System) are available as a single package providing full support of the TMS370 family devices.

<b>Part Number</b>	<b>Description</b>
TMDS3792210	TMS370 Development

### **17.4.6 XDS Upgrade**

XDS/22 systems can be upgraded to a PACT XDS/22 system. This upgrade is handled through Factory Repair and requires the XDS/22 system to be shipped to the factory. Please contact Factory Repair for further information.

<b>Part Number</b>	<b>Description</b>
TMDX372211	XDS/22 upgrade to PACT XDS/22

### **17.4.7 XDS Target Connectors**

For additional or replacement XDS Target Connectors please contact TI Factory Repair.



Introduction	1
Assembly Language Instruction Set	13
TMS370 Family Devices	2
Design Aids	14
CPU and Memory Organization	3
Development Support	15
System and Digital I/O Configuration	4
Electrical Specifications	16
Interrupts and System Reset	5
Customer Information	17
EEPROM Modules	6
Appendices	A-H
Timer 1 Module	7
Timer 2 Module	8
Serial Communications Interface (SCI) Port	9
Serial Peripheral Interface (SPI) Module	10
Analog-to-Digital Converter Module	11
TMS370 Programmable Acquisition and Control Timer	12



# Peripheral File Map

---

---

---

This appendix summarizes the Peripheral File (PF) and control bit information into a single location for reference.

Each PF register is presented as a row of boxes containing the control or status bits belonging to the register. The register symbol (e.g., SCCR0) and the PF hex address (i.e., P010) are to the left of each register.

The read/write accessibility of each bit is indicated in parentheses below each bit symbol, with the following definitions:

- R – read
- W – write
- P – write in the privilege mode only
- C – clear only
- S – set only
- -0 – cleared by RESET
- -1 – set by RESET
- -† – this bit exhibits special behavior during or after RESET; see the description for this bit in the appropriate section (both bit and register are index entries).

### System Configuration and Port Control Registers

Bit #	7	6	5	4	3	2	1	0
SCCR1 P010	COLD START (RC-†)	OSC POWER (RP-0)	PF AUTO WAIT (RW-0)	OSC FLT FLAG (RW-†)	MODE PIN WPO (R-†)	MC PIN DATA (R-†)	—	UP/IC MODE (R)
SCCR1 P011	—	—	—	AUTOWAIT DISABLE (RP-0)	—	MEMORY DISABLE (RP-†)	—	—
SCCR2 P012	HALT/STANDBY (RP-0)	PWRDWN/IDLE (RP-0)	OSC FLT RST ENA (RP-0)	BUS STEST (RP-0)	CPU STEST (RP-1)	OSC FLT DISABLE (RP-0)	INT1 NMI (RP-0)	PRIVILEGE DISABLE (RS-0)
INT1 P017	INT1 FLAG (RC-0)	INT1 PIN DATA (R-0)	—	—	—	INT1 POLARITY (RW-0)	INT1 PRIORITY (RW-0)	INT1 ENABLE (RW-0)
INT2 P018	INT2 FLAG (RC-0)	INT2 PIN DATA (R-0)	—	INT2 DATA DIR (RW-0)	INT2 DATA OUT (RW-0)	INT2 POLARITY (RW-0)	INT2 PRIORITY (RW-0)	INT2 ENABLE (RW-0)
INT3 P019	INT3 FLAG (RC-0)	INT3 PIN DATA (R-0)	—	INT3 DATA DIR (RW-0)	INT3 DATA OUT (RW-0)	INT3 POLARITY (RW-0)	INT3 PRIORITY (RW-0)	INT3 ENABLE (RW-0)
DEECTL P01A	BUSY (R-†)	—	—	—	—	AP (RW-0)	W1W0 (RW-0)	EXE (RW-0)
PEECTL P01C	BUSY (R-†)	—	—	—	—	AP (RW-0)	W1W0 (RW-0)	EXE (RW-0)
EPCTL P01C	BUSY (R-†)	VPPS (RW-0)	—	—	—	—	W0 (RW-0)	EXE (RW-0)

APOINT 2 P021	PORT A CONTROL REGISTER 2
ADATA P022	PORT A DATA
ADIR P023	PORT A DIRECTION
BPOINT2 P025	PORT B CONTROL REGISTER 2
BDATA P026	PORT B DATA
BDIR P027	PORT B DIRECTION
CPOINT2 P029	PORT C CONTROL REGISTER 2
CDATA P02A	PORT C DATA
CDIR P02B	PORT C DIRECTION
DPOINT1 P02C	PORT D CONTROL REGISTER 1
DPOINT2 P02D	PORT D CONTROL REGISTER 2
DDATA P02E	PORT D DATA
DDIR P02F	PORT D DIRECTION

A  
H

**SPI Control Registers**

Bit #	7	6	5	4	3	2	1	0
SPICCR P030	SPI SW RESET (RW-0)	CLOCK POLARITY (RW-0)	SPI BIT RATE2 (RW-0)	SPI BIT RATE1 (RW-0)	SPI BIT RATE0 (RW-0)	SPI CHAR2 (RW-0)	SPI CHAR1 (RW-0)	SPI CHAR0 (RW-0)
SPICTL P031	RECEIVER OVERRUN (R-0)	SPI INT FLAG (R-0)	—	—	—	MASTER / SLAVE (RW-0)	TALK (RW-0)	SPI INT ENA (RW-0)
SPIBUF P037	RCVD7 (R-0)	RCVD6 (R-0)	RCVD5 (R-0)	RCVD4 (R-0)	RCVD3 (R-0)	RCVD2 (R-0)	RCVD1 (R-0)	RCVD0 (R-0)
SPIDAT P039	SDAT7 (RW-0)	SDAT6 (RW-0)	SDAT5 (RW-0)	SDAT4 (RW-0)	SDAT3 (RW-0)	SDAT2 (RW-0)	SDAT1 (RW-0)	SDAT0 (RW-0)
SPIPC1 P03D	—	—	—	—	SPICKL DATA IN (R-0)	SPICKL DATA OUT (RW-0)	SPICKL FUNCTION (RW-0)	SPICKL DATA DIR (RW-0)
SPIPC2 P03E	SPISIMO DATA IN (R-0)	SPISIMO DATA OUT (RW-0)	SPISIMO FUNCTION (RW-0)	SPISIMO DATA DIR (RW-0)	SPISIMO DATA IN (R-0)	SPISIMO DATA OUT (RW-0)	SPISIMO FUNCTION (RW-0)	SPISIMO DATA DIR (RW-0)
SPIPRI P03F	SPI STEST (RP-0)	SPI PRIORITY (RP-0)	SPI ESPEN (RP-0)	—	—	—	—	—

**Timer 1 Control Registers**

Bit #	7	6	5	4	3	2	1	0	
T1CNTR MSB P040	Bit 15		T1 COUNTER MSB					Bit 8	
T1CNTR LSB P041	Bit 7		T1 COUNTER LSB					Bit 0	
T1C MSB P042	Bit 15		COMPARE REGISTER MSB					Bit 8	
T1C LSB P043	Bit 7		COMPARE REGISTER LSB					Bit 0	
T1CC MSB P044	Bit 15		CAPTURE / COMPARE REGISTER MSB					Bit 8	
T1CC LSB P045	Bit 7		CAPTURE / COMPARE REGISTER LSB					Bit 0	
WDCNTR MSB P046	Bit 15		WATCHDOG COUNTER MSB					Bit 8	
WDCNTR LSB P047	Bit 7		WATCHDOG COUNTER LSB					Bit 0	
WDRST P048	Bit 7		WATCHDOG RESET KEY					Bit 0	
T1CTL1 P049	WD OVRFL TAP SEL (RP-0)	WD INPUT SELECT 2 (RP-0)	WD INPUT SELECT 1 (RP-0)	WD INPUT SELECT 0 (RP-0)	—	T1 INPUT SELECT 2 (RW-0)	T1 INPUT SELECT 1 (RW-0)	T1 INPUT SELECT 0 (RW-0)	
T1CTL2 P04A	WD OVRFL RST ENA (RS-0)	WD OVRFL INT ENA (RW-0)	WD OVRFL INT FLAG (RC-1)	T1 OVRFL INT ENA (RW-0)	T1 OVRFL INT FLAG (RC-0)	—	—	T1 SW RESET (S-0)	
Dual Compare Mode									
T1CTL3 P04B	T1EDGE INT FLAG (RC-0)	T1C2 INT FLAG (RC-0)	T1C1 INT FLAG (RC-0)	—	—	T1EDGE INT ENA (RW-0)	T1C2 INT ENA (RW-0)	T1C1 INT ENA (RW-0)	
Capture / Compare Mode									
T1EDGE INT FLAG (RC-0)	—	T1C1 INT FLAG (RC-0)	—	—	T1EDGE INT ENA (RW-0)	—	T1C1 INT ENA (RW-0)	—	
Dual Compare Mode									
T1CTL4 P04C	T1 MODE = 0 (RW-0)	T1C1 OUT ENA (RW-0)	T1C2 OUT ENA (RW-0)	T1C1 RST ENA (RW-0)	T1CR OUT ENA (RW-0)	T1EDGE POLARITY (RW-0)	T1CR RST ENA (RW-0)	T1EDGE DET ENA (RW-0)	
Capture / Compare Mode									
T1 MODE = 1 (RW-0)	T1C1 OUT ENA (RW-0)	—	T1C1 RST ENA (RW-0)	—	T1EDGE POLARITY (RW-0)	—	T1EDGE DET ENA (RW-0)	—	
T1PC1 P04D	—	—	—	—	T1EVT DATA IN (R-0)	T1EVT DATA OUT (RW-0)	T1EVT FUNCTION (RW-0)	T1EVT DATA DIR (RW-0)	
T1PC2 P04E	T1PWM DATA IN (R-0)	T1PWM DATA OUT (RW-0)	T1PWM FUNCTION (RW-0)	T1PWM DATA DIR (RW-0)	T1IC/CR DATA IN (R-0)	T1IC/CR DATA OUT (RW-0)	T1IC/CR FUNCTION (RW-0)	T1IC/CR DATA DIR (RW-0)	
T1PRI P04F	T1 STEST (RP-0)	T1 PRIORITY (RP-0)	—	—	—	—	—	—	

AH

## PACT Control Registers

Bit#	7	6	5	4	3	2	1	0
PACTSCR P040	DEFTIM OVRFL INT ENA (RW-0)	DEFTIM OVRFL INT FLAG (RC-0)	CMD / DEF AREA ENA (RW-0)	FAST MODE SELECT (RP-0)	PACT PRESCALE SELECT 3 (RP-0)	PACT PRESCALE SELECT 2 (RP-0)	PACT PRESCALE SELECT 1 (RP-0)	PACT PRESCALE SELECT 0 (RP-0)
CDSTART P041	CMD/DEF AREA INT ENA (RW-0)	—	CMD/DEF AREA START BIT 5 (RW-0)	CMD/DEF AREA START BIT 4 (RW-0)	CMD/DEF AREA START BIT 3 (RW-0)	CMD/DEF AREA START BIT 2 (RW-0)	—	—
CDEND P042	—	CMD/DEF AREA END BIT 6 (RW-0)	CMD/DEF AREA END BIT 5 (RW-0)	CMD/DEF AREA END BIT 4 (RW-0)	CMD/DEF AREA END BIT 3 (RW-0)	CMD/DEF AREA END BIT 2 (RW-0)	—	—
BUFPTN P043	—	—	BUFFER POINTER BIT 5 (RW-0)	BUFFER POINTER BIT 4 (RW-0)	BUFFER POINTER BIT 3 (RW-0)	BUFFER POINTER BIT 2 (RW-0)	BUFFER POINTER BIT 1 (RW-0)	—
SCICTL P045	PACT RXRDY (RC-0)	PACT TXRDY (R-1)	PACT PARITY (R-0)	PACT FE (RC-0)	PACT SCI RX INT ENA (RW-0)	PACT SCI TX INT ENA (RW-0)	—	PACT SCI SW RESET (RW-0)
RXBUFP P046	PACT RXDT7 (R-0)	PACT RXDT6 (R-0)	PACT RXDT5 (R-0)	PACT RXDT4 (R-0)	PACT RXDT3 (R-0)	PACT RXDT2 (R-0)	PACT RXDT1 (R-0)	PACT RXDT0 (R-0)
TXBUFP P047	PACT TXDT7 (RW-0)	PACT TXDT6 (RW-0)	PACT TXDT5 (RW-0)	PACT TXDT4 (RW-0)	PACT TXDT3 (RW-0)	PACT TXDT2 (RW-0)	PACT TXDT1 (RW-0)	PACT TXDT0 (RW-0)
OPSTATE P048	PACT OP8 STATE (RW-0)	PACT OP7 STATE (RW-0)	PACT OP6 STATE (RW-0)	PACT OP5 STATE (RW-0)	PACT OP4 STATE (RW-0)	PACT OP3 STATE (RW-0)	PACT OP2 STATE (RW-0)	PACT OP1 STATE (RW-0)
CDFLAGS P049	CMD/DEF INT 7 FLAG (RC-0)	CMD/DEF INT 6 FLAG (RC-0)	CMD/DEF INT 5 FLAG (RC-0)	CMD/DEF INT 4 FLAG (RC-0)	CMD/DEF INT 3 FLAG (RC-0)	CMD/DEF INT 2 FLAG (RC-0)	CMD/DEF INT 1 FLAG (RC-0)	CMD/DEF INT 0 FLAG (RC-0)
CPCTL1 P04A	CP2 INT ENA (RW-0)	CP2 INT FLAG (RC-0)	CP2 CAPT RISING EDGE (RW-0)	CP2 CAPT FALLING EDGE (RW-0)	CP1 INT ENA (RW-0)	CP1 INT FLAG (RC-0)	CP1 CAPT RISING EDGE (RW-0)	CP1 CAPT FALLING EDGE (RW-0)
CPCTL2 P04B	CP4 INT ENA (RW-0)	CP4 INT FLAG (RC-0)	CP4 CAPT RISING EDGE (RW-0)	CP4 CAPT FALLING EDGE (RW-0)	CP3 INT ENA (RW-0)	CP3 INT FLAG (RC-0)	CP3 CAPT RISING EDGE (RW-0)	CP3 CAPT FALLING EDGE (RW-0)
CPCTL3 P04C	CP6 INT ENA (RW-0)	CP6 INT FLAG (RC-0)	CP6 CAPT RISING EDGE (RW-0)	CP6 CAPT FALLING EDGE (RW-0)	CP5 INT ENA (RW-0)	CP5 INT FLAG (RC-0)	CP5 CAPT RISING EDGE (RW-0)	CP5 CAPT FALLING EDGE (RW-0)
CPPRE P04D	BUFFER HALF/ FULL INT ENA (RW-0)	BUFFER HALF/ FULL INT FLAG (RC-0)	INPUT CAPT PRESCALE SELECT 3 (RW-0)	INPUT CAPT PRESCALE SELECT 2 (RW-0)	INPUT CAPT PRESCALE SELECT 1 (RW-0)	CP6 EVENT ONLY (RW-0)	EVENT COUNTER SW RESET (RW-0)	OP SET/CLR SELECT (RW-0)
WDRST P04E	WATCHDOG RESET KEY							
PACTPRI P04F	PACT STEST (RP-0)	—	PACT GROUP 1 PRIORITY (RP-0)	PACT GROUP 2 PRIORITY (RP-0)	PACT GROUP 3 PRIORITY (RP-0)	PACT MODE SELECT (RP-0)	PACT WD PRESCALE SELECT 1 (RP-0)	PACT WD PRESCALE SELECT 0 (RP-0)

**SCI Control Registers**

Bit #	7	6	5	4	3	2	1	0
SCICCR P050	STOP BITS (RW-0)	EVEN/ODD PARITY (RW-0)	PARITY ENABLE (RW-0)	ASYNC/ ISOSYNC (RW-0)	ADDRESS / IDLE WUP (RW-0)	SCI CHAR2 (RW-0)	SCI CHAR1 (RW-0)	SCI CHAR0 (RW-0)
SCICTL P051	—	—	SCI SW RESET (RW-0)	CLOCK (RW-0)	TXWAKE (RS-0)	SLEEP (RW-0)	TXENA (RW-0)	RXENA (RW-0)
BAUD MSB P052	BAUDF (MSB) (RW-0)	BAUDE (RW-0)	BAUDD (RW-0)	BAUDC (RW-0)	BAUDB (RW-0)	BAUDA (RW-0)	BAUD9 (RW-0)	BAUD8 (RW-0)
BAUD LSB P053	BAUD7 (RW-0)	BAUD6 (RW-0)	BAUD5 (RW-0)	BAUD4 (RW-0)	BAUD3 (RW-0)	BAUD2 (RW-0)	BAUD1 (RW-0)	BAUD0 (LSB) (RW-0)
TXCTL P054	TXRDY (R-1)	TX EMPTY (R-1)	—	—	—	—	—	SCI TX INT ENA (RW-0)
RXCTL P055	RX ERROR (R-0)	RXRDY (R-0)	BRKDT (R-0)	FE (R-0)	OE (R-0)	PE (R-0)	RXWAKE (R-0)	SCI RX INT ENA (RW-0)
RXBUF P057	RXDT7 (R-0)	RXDT6 (R-0)	RXDT5 (R-0)	RXDT4 (R-0)	RXDT3 (R-0)	RXDT2 (R-0)	RXDT1 (R-0)	RXDT0 (R-0)
TXBUF P059	TXDT7 (RW-0)	TXDT6 (RW-0)	TXDT5 (RW-0)	TXDT4 (RW-0)	TXDT3 (RW-0)	TXDT2 (RW-0)	TXDT1 (RW-0)	TXDT0 (RW-0)
SCIPC1 P05D	—	—	—	—	SCICLK DATA IN (R-0)	SCICLK DATA OUT (RW-0)	SCICLK FUNCTION (RW-0)	SCICLK DATA DIR (RW-0)
SCIPC2 P05E	SCITXD DATA IN (R-0)	SCITXD DATA OUT (RW-0)	SCITXD FUNCTION (RW-0)	SCITXD DATA DIR (RW-0)	SCIRXD DATA IN (R-0)	SCIRXD DATA OUT (RW-0)	SCIRXD FUNCTION (RW-0)	SCIRXD DATA DIR (RW-0)
SCIPRI P05F	SCI STEST (RP-0)	SCITX PRIORITY (RP-0)	SCIRX PRIORITY (RP-0)	SCI ESPEN (RP-0)	—	—	—	—





## Timer 2 Control Registers

Bit #	7	6	5	4	3	2	1	0
T2CNTR MSB P060	Bit 15	T2 COUNTER MSB						Bit 8
T2CNTR LSB P061	Bit 7	T2 COUNTER LSB						Bit 0
T2C MSB P062	Bit 15	COMPARE REGISTER MSB						Bit 8
T2C LSB P063	Bit 7	COMPARE REGISTER LSB						Bit 0
T2CC MSB P064	Bit 15	CAPTURE/COMPARE REGISTER MSB						Bit 8
T2CC LSB P065	Bit 7	CAPTURE/COMPARE REGISTER LSB						Bit 0
T2IC MSB P066	Bit 15	CAPTURE REGISTER 2 MSB						Bit 8
T2IC LSB P067	Bit 7	CAPTURE REGISTER 2 LSB						Bit 0
T2CTL1 P06A	—	—	—	T2 OVRFL INT ENA (RW-0)	T2 OVRFL INT FLAG (RC-0)	T2 INPUT SELECT 1 (RW-0)	T2 INPUT SELECT 0 (RW-0)	T2 SW RESET (S-0)
Dual Compare Mode								
T2CTL2 P06B	T2EDGE1 INT FLAG (RC-0)	T2C2 INT FLAG (RC-0)	T2C1 INT FLAG (RC-0)	—	—	T2EDGE1 INT ENA (RW-0)	T2C2 INT ENA (RW-0)	T2C1 INT ENA (RW-0)
Dual Capture Mode								
	T2EDGE1 INT FLAG (RC-0)	T2EDGE2 INT FLAG (RC-0)	T2C1 INT FLAG (RC-0)	—	—	T2EDGE1 INT ENA (RW-0)	T2EDGE2 INT ENA (RW-0)	T2C1 INT ENA (RW-0)
Dual Compare Mode								
T2CTL3 P06C	T2 MODE = 0 (RW-0)	T2C1 OUT ENA (RW-0)	T2C2 OUT ENA (RW-0)	T2C1 RST ENA (RW-0)	T2EDGE1 OUT ENA (RW-0)	T2EDGE1 POLARITY (RW-0)	T2EDGE1 RST ENA (RW-0)	T2EDGE1 DET ENA (RW-0)
Dual Capture Mode								
	T2 MODE = 1 (RW-0)	—	—	T2C1 RST ENA (RW-0)	T2EDGE2 POLARITY (RW-0)	T2EDGE1 POLARITY (RW-0)	T2EDGE2 DET ENA (RW-0)	T2EDGE1 DET ENA (RW-0)
T2PC1 P06D	—	—	—	—	T2EVT DATA IN (R-0)	T2EVT DATA OUT (RW-0)	T2EVT FUNCTION (RW-0)	T2EVT DATA DIR (RW-0)
T2PC2 P06E	T2IC2/ PWM DATA IN (R-0)	T2IC2/ PWM DATA OUT (RW-0)	T2IC2/ PWM FUNCTION (RW-0)	T2IC2/ PWM DATA DIR (RW-0)	T2IC1/CR DATA IN (R-0)	T2IC1/CR DATA OUT (RW-0)	T2IC1/CR FUNCTION (RW-0)	T2IC1/CR DATA DIR (RW-0)
T2PRI P06F	T2 STEST (RP-0)	T2 PRIORITY (RP-0)	—	—	—	—	—	—

**A/D Control Registers**

Bit #	7	6	5	4	3	2	1	0
ADCTL P070	CONVERT START (RW-0)	SAMPLE START (RW-0)	REF VOLT SELECT2 (RW-0)	REF VOLT SELECT1 (RW-0)	REF VOLT SELECT0 (RW-0)	AD INPUT SELECT2 (RW-0)	AD INPUT SELECT1 (RW-0)	AD INPUT SELECT0 (RW-0)
ADSTAT P071	—	—	—	—	—	AD READY (R-1)	AD INT FLAG (RC-0)	AD INT ENA (RW-0)
ADDATA P072	DATA7 (R-0)	DATA6 (R-0)	DATA5 (R-0)	DATA4 (R-0)	DATA3 (R-0)	DATA2 (R-0)	DATA1 (R-0)	DATA0 (R-0)
ADIN P07D	PORT E DATA AN 7 (R-0)	PORT E DATA AN 6 (R-0)	PORT E DATA AN 5 (R-0)	PORT E DATA AN 4 (R-0)	PORT E DATA AN 3 (R-0)	PORT E DATA AN 2 (R-0)	PORT E DATA AN 1 (R-0)	PORT E DATA AN 0 (R-0)
ADENA P07E	PORT E INPUT ENA 7 (RW-0)	PORT E INPUT ENA 6 (RW-0)	PORT E INPUT ENA 5 (RW-0)	PORT E INPUT ENA 4 (RW-0)	PORT E INPUT ENA 3 (RW-0)	PORT E INPUT ENA 2 (RW-0)	PORT E INPUT ENA 1 (RW-0)	PORT E INPUT ENA 0 (RW-0)
ADPRI P07F	AD STEST (RP-0)	AD PRIORITY (RP-0)	AD ESPEN (RP-0)	—	—	—	—	—



# Block Diagrams

---

---

---

This appendix summarizes the block diagrams of the major circuits. The control bits are shown in these diagrams in the following format:

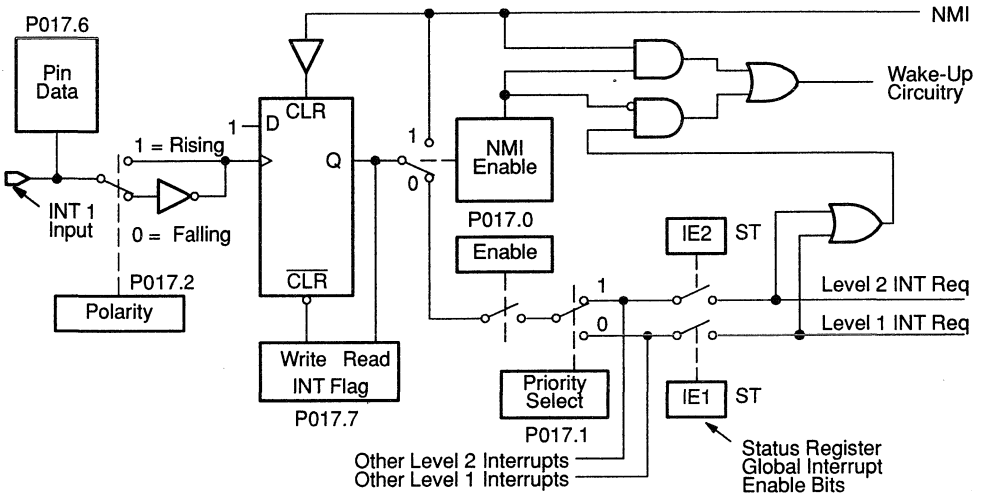
(xx.n) 4A.0 Bit location convention used in figures, where xx is the hexadecimal address of the peripheral register containing the bit and n is the bit number (7 = msb, 0 = lsb).

Each block diagram also has the associated PF register(s) displayed. The PF register is presented as a row of boxes containing the control or status bits belonging to the register. The register symbol (e.g., SCCR0) and the PF hex address (i.e., P010) are to the left of each register.

The read/write accessibility of each bit is indicated in parentheses below each bit symbol, with the following definitions:

- R – read
- W – write
- P – write in the privilege mode only
- C – clear only
- S – set only
- 0 – cleared by RESET
- 1 – set by RESET
- † – this bit exhibits special behavior during or after RESET; see the description for this bit in the appropriate section (both bit and register are index entries).

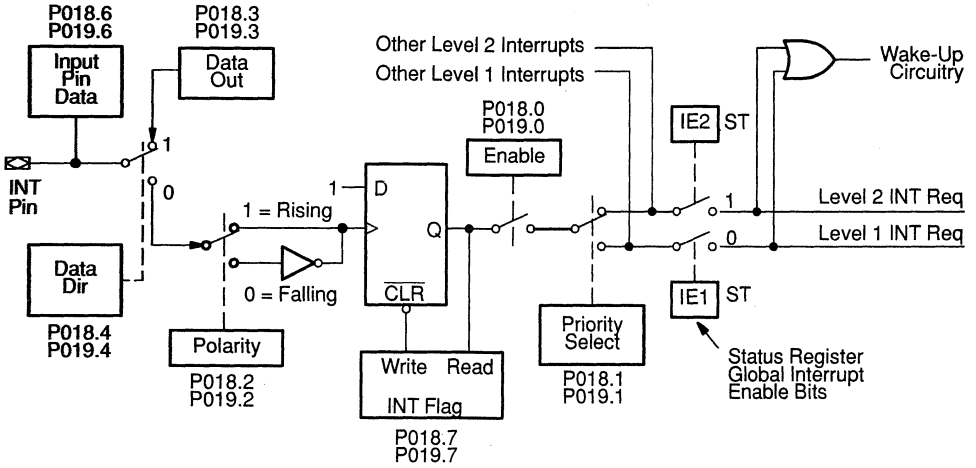
**Figure B-1. Interrupt 1 Block Diagram**



Bit #	7	6	5	4	3	2	1	0
SCCR2 P012	HALT/ STANDBY (RP-0)	PWRDWN/ IDLE (RP-0)	OSC FLT RST ENA (RP-0)	BUS STEST (RP-0)	CPU STEST (RP-1)	OSC FLT DISABLE (RP-0)	INT1 NMI (RP-0)	PRIVILEGE DISABLE (RS-0)
INT1 P017	INT1 FLAG (RC-0)	INT1 Pin DATA (R-0)	—	—	—	INT1 POLARITY (RW-0)	INT1 PRIORITY (RW-0)	INT1 ENABLE (RW-0)

A  
H

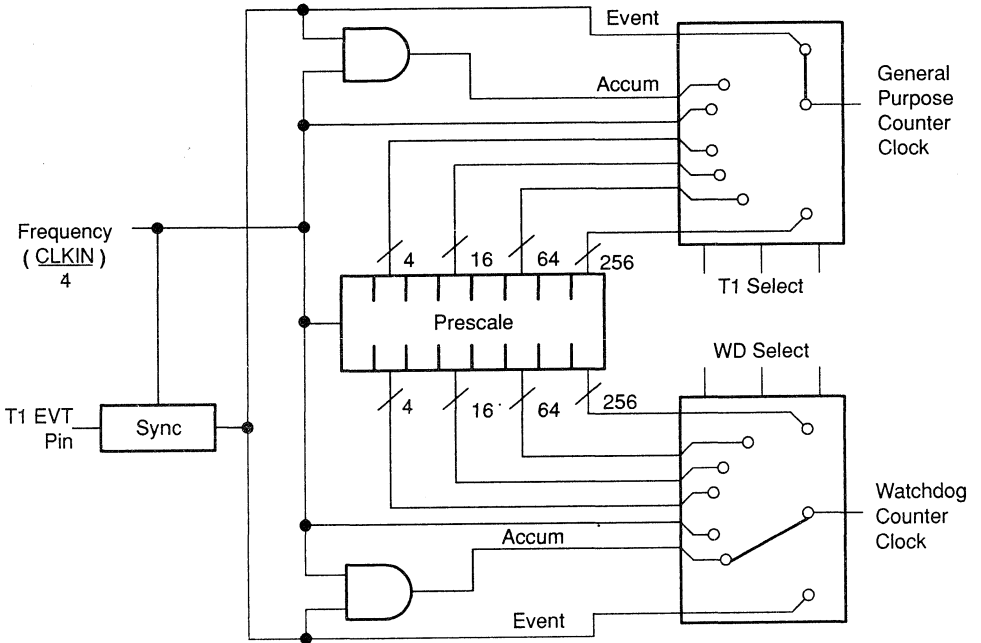
**Figure B-2. Interrupts 2 and 3 Block Diagram**



Bit #	7	6	5	4	3	2	1	0
INT2 P018	INT2 FLAG (RC-0)	INT2 PIN DATA (R-0)	—	INT2 DATA DIR (RW-0)	INT2 DATA OUT (RW-0)	INT2 POLARITY (RW-0)	INT2 PRIORITY (RW-0)	INT2 ENABLE (RW-0)
INT3 P019	INT3 FLAG (RC-0)	INT3 PIN DATA (R-0)	—	INT3 DATA DIR (RW-0)	INT3 DATA OUT (RW-0)	INT3 POLARITY (RW-0)	INT3 PRIORITY (RW-0)	INT3 ENABLE (RW-0)



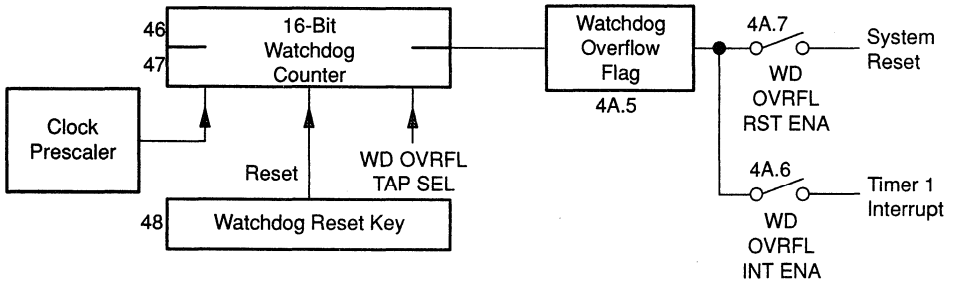
**Figure B-3. Timer 1 System Clock Prescaler**



Bit #	7	6	5	4	3	2	1	0
T1CTL1 P049	WD OVRFL TAP SEL (RP-0)	WD INPUT SELECT 2 (RP-0)	WD INPUT SELECT 1 (RP-0)	WD INPUT SELECT 0 (RP-0)	—	T1 INPUT SELECT 2 (RW-0)	T1 INPUT SELECT 1 (RW-0)	T1 INPUT SELECT 0 (RW-0)



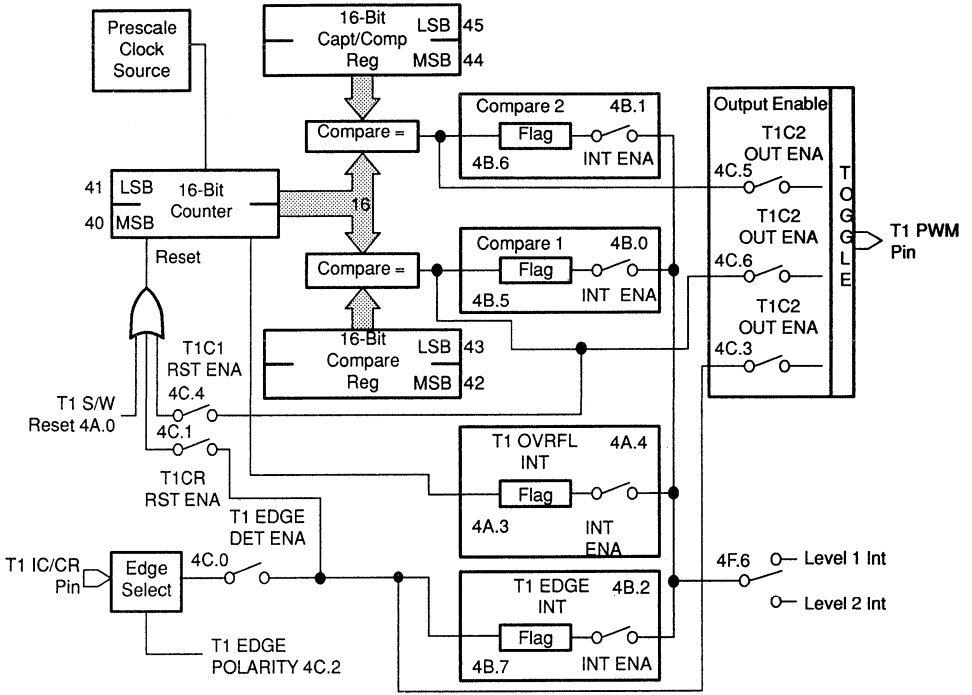
Figure B-4. Timer 1: Watchdog Timer



Bit #	7	6	5	4	3	2	1	0
WDCNTR MSB P046	Bit 15	WATCHDOG COUNTER MSB						Bit 8
WDCNTR LSB P047	Bit 7	WATCHDOG COUNTER LSB						Bit 0
WDRST P048	Bit 7	WATCHDOG RESET KEY						Bit 0
T1CTL1 P049	WD OVRFL TAP SEL (RP-0)	WD INPUT SELECT 2 (RP-0)	WD INPUT SELECT 1 (RP-0)	WD INPUT SELECT 0 (RP-0)	—	T1 INPUT SELECT 2 (RW-0)	T1 INPUT SELECT 1 (RW-0)	T1 INPUT SELECT 0 (RW-0)
T1CTL2 P04A	WD OVRFL RST ENA (RS-0)	WD OVRFL INT ENA (RW-0)	WD OVRFL INT FLAG (RC-1)	T1 OVRFL INT ENA (RW-0)	T1 OVRFL INT FLAG (RC-0)	—	—	T1 SW RESET (S-0)



**Figure B-5. Timer 1: Dual Compare Mode**





**Figure B–5. Timer 1: Dual Compare Mode (Concluded)**

Bit #	7	6	5	4	3	2	1	0
T1CNTR MSB P040	Bit 15	T1 COUNTER MSB						Bit 8
T1CNTR LSB P041	Bit 7	T1 COUNTER LSB						Bit 0
T1C MSB P042	Bit 15	COMPARE REGISTER MSB						Bit 8
T1C LSB P043	Bit 7	COMPARE REGISTER LSB						Bit 0
T1CC MSB P044	Bit 15	CAPTURE / COMPARE REGISTER MSB						Bit 8
T1CC LSB P045	Bit 7	CAPTURE / COMPARE REGISTER LSB						Bit 0
WDCNTR MSB P046	Bit 15	WATCHDOG COUNTER MSB						Bit 8
WDCNTR LSB P047	Bit 7	WATCHDOG COUNTER LSB						Bit 0
WDRST P048	Bit 7	WATCHDOG RESET KEY						Bit 0
T1CTL1 P049	WD OVRFL TAP SEL (RP-0)	WD INPUT SELECT 2 (RP-0)	WD INPUT SELECT 1 (RP-0)	WD INPUT SELECT 0 (RP-0)	—	T1 INPUT SELECT 2 (RW-0)	T1 INPUT SELECT 1 (RW-0)	T1 INPUT SELECT 0 (RW-0)
T1CTL2 P04A	WD OVRFL RST ENA (RS-0)	WD OVRFL INT ENA (RW-0)	WD OVRFL INT FLAG (RC-†)	T1 OVRFL INT ENA (RW-0)	T1 OVRFL INT FLAG (RC-0)	—	—	T1 SW RESET (S-0)
T1CTL3 P04B	T1EDGE INT FLAG (RC-0)	T1C2 INT FLAG (RC-0)	T1C1 INT FLAG (RC-0)	—	—	T1EDGE INT ENA (RW-0)	T1C2 INT ENA (RW-0)	T1C1 INT ENA (RW-0)
T1CTL4 P04C	T1 MODE = 0 (RW-0)	T1C1 OUT ENA (RW-0)	T1C2 OUT ENA (RW-0)	T1C1 RST ENA (RW-0)	T1CR OUT ENA (RW-0)	T1 EDGE POLARITY (RW-0)	T1CR RST ENA (RW-0)	T1EDGE DET ENA (RW-0)
T1PC1 P04D	—	—	—	—	T1EVT DATA IN (R-0)	T1EVT DATA OUT (RW-0)	T1EVT FUNCTION (RW-0)	T1EVT DATA DIR (RW-0)
T1PC2 P04E	T1PWM DATA IN (R-0)	T1PWM DATA OUT (RW-0)	T1PWM FUNCTION (RW-0)	T1PWM DATA DIR (RW-0)	T1IC/CR DATA IN (R-0)	T1IC/CR DATA OUT (RW-0)	T1IC/CR FUNCTION (RW-0)	T1IC/CR DATA DIR (RW-0)
T1PRI P04F	T1 STEST (RP-0)	T1 PRIORITY (RP-0)	—	—	—	—	—	—

A—  
H

Figure B-6. Timer 1: Capture/Compare Mode

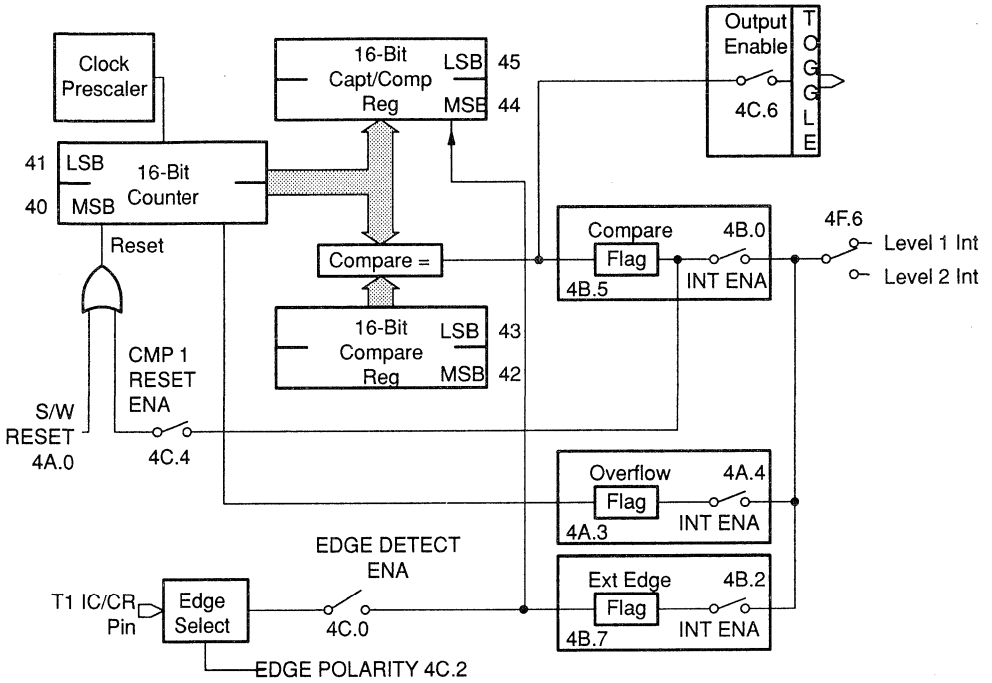


Figure B–6. Timer 1: Capture/Compare Mode (Concluded)

Bit #	7	6	5	4	3	2	1	0
T1CNTR MSB P040	Bit 15	T1 COUNTER MSB						Bit 8
T1CNTR LSB P041	Bit 7	T1 COUNTER LSB						Bit 0
T1C MSB P042	Bit 15	COMPARE REGISTER MSB						Bit 8
T1C LSB P043	Bit 7	COMPARE REGISTER LSB						Bit 0
T1CC MSB P044	Bit 15	CAPTURE / COMPARE REGISTER MSB						Bit 8
T1CC LSB P045	Bit 7	CAPTURE / COMPARE REGISTER LSB						Bit 0
WDCNTR MSB P046	Bit 15	WATCHDOG COUNTER MSB						Bit 8
WDCNTR LSB P047	Bit 7	WATCHDOG COUNTER LSB						Bit 0
WDRST P048	Bit 7	WATCHDOG RESET KEY						Bit 0
T1CTL1 P049	WD OVRFL TAP SEL (RP-0)	WD INPUT SELECT 2 (RP-0)	WD INPUT SELECT 1 (RP-0)	WD INPUT SELECT 0 (RP-0)	—	T1 INPUT SELECT 2 (RW-0)	T1 INPUT SELECT 1 (RW-0)	T1 INPUT SELECT 0 (RW-0)
T1CTL2 P04A	WD OVRFL RST ENA (RS-0)	WD OVRFL INT ENA (RW-0)	WD OVRFL INT FLAG (RC-1)	T1 OVRFL INT ENA (RW-0)	T1 OVRFL INT FLAG (RC-0)	—	—	T1 SW RESET (S-0)
T2CTL3 P04B	T1EDGE INT FLAG (RC-0)	—	T1C1 INT FLAG (RC-0)	—	—	T1EDGE INT ENA (RW-0)	—	T1C1 INT ENA (RW-0)
T1CTL4 P04C	T1 MODE = 1 (RW-0)	T1C1 OUT ENA (RW-0)	—	T1C1 RST ENA (RW-0)	—	T1 EDGE POLARITY (RW-0)	—	T1EDGE DET ENA (RW-0)
T1PC1 P04D	—	—	—	—	T1EVT DATA IN (R-0)	T1EVT DATA OUT (RW-0)	T1EVT FUNCTION (RW-0)	T1EVT DATA DIR (RW-0)
T1PC2 P04E	T1PWM DATA IN (R-0)	T1PWM DATA OUT (RW-0)	T1PWM FUNCTION (RW-0)	T1PWM DATA DIR (RW-0)	T1IC/CR DATA IN (R-0)	T1IC/CR DATA OUT (RW-0)	T1IC/CR FUNCTION (RW-0)	T1IC/CR DATA DIR (RW-0)
T1PRI P04F	T1 STEST (RP-0)	T1 PRIORITY (RP-0)	—	—	—	—	—	—

**Figure B-7. Timer 2: Dual Compare Mode**

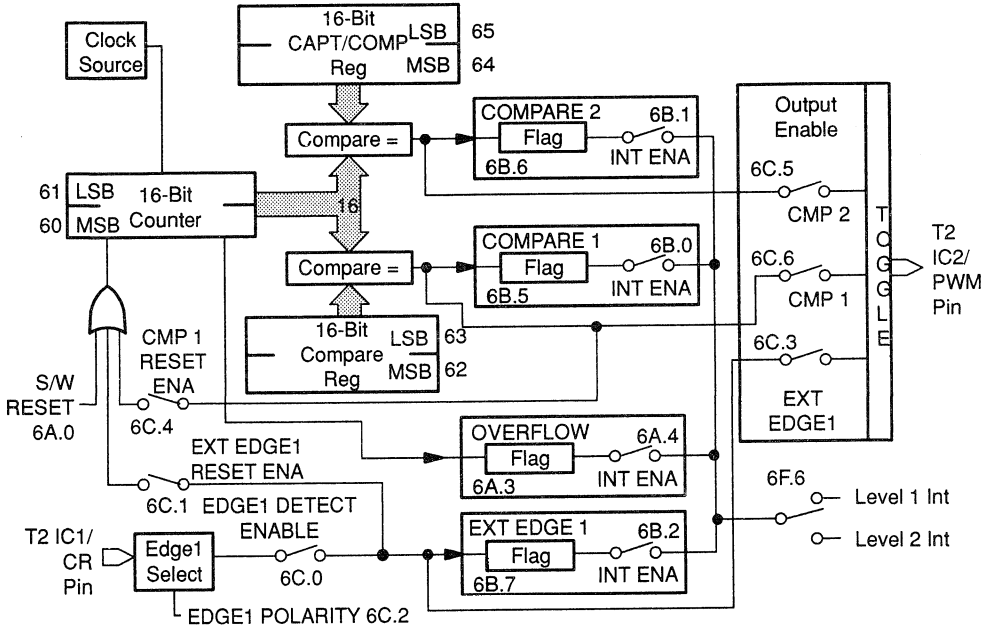
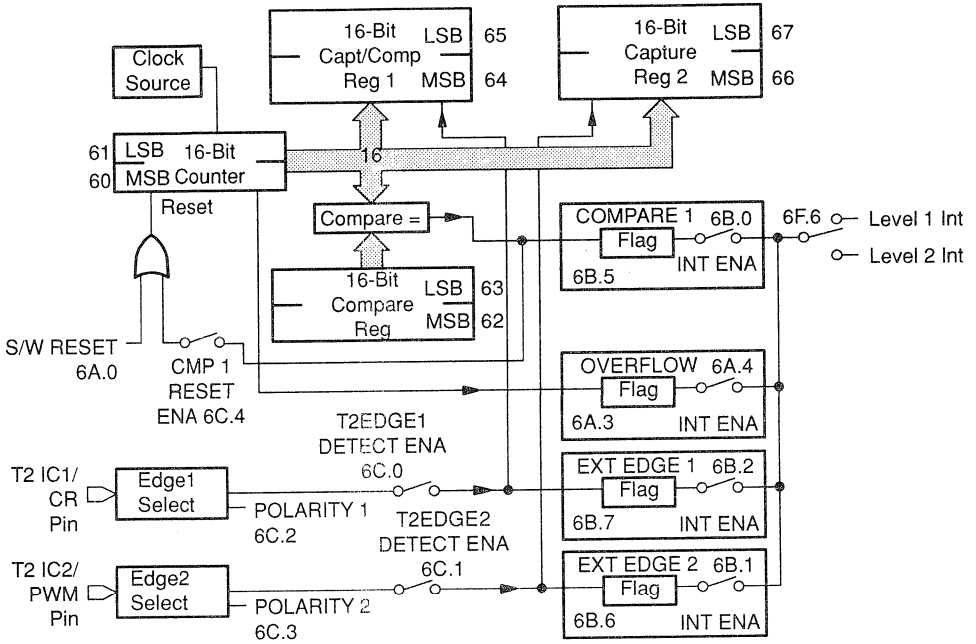


Figure B-7. Timer 2: Dual Compare Mode (Concluded)

Bit #	7	6	5	4	3	2	1	0
T2CNTR MSB P060	Bit 15	T2 COUNTER MSB						Bit 8
T2CNTR LSB P061	Bit 7	T2 COUNTER LSB						Bit 0
T2C MSB P062	Bit 15	COMPARE REGISTER MSB						Bit 8
T2C LSB P063	Bit 7	COMPARE REGISTER LSB						Bit 0
T2CC MSB P064	Bit 15	CAPTURE/COMPARE REGISTER MSB						Bit 8
T2CC LSB P065	Bit 7	CAPTURE/COMPARE REGISTER LSB						Bit 0
T2IC MSB P066	Bit 15	CAPTURE REGISTER 2 MSB						Bit 8
T2IC LSB P067	Bit 7	CAPTURE REGISTER 2 LSB						Bit 0
T2CTL1 P06A	—	—	—	T2 OVRFL INT ENA (RW-0)	T2 OVRFL INT FLAG (RC-0)	T2 INPUT SELECT 1 (RW-0)	T2 INPUT SELECT 0 (RW-0)	T2 SW RESET (S-0)
T2CTL2 P06B	T2EDGE1 INT FLAG (RC-0)	T2C2 INT FLAG (RC-0)	T2C1 INT FLAG (RC-0)	—	—	T2EDGE1 INT ENA (RW-0)	T2C2 INT ENA (RW-0)	T2C1 INT ENA (RW-0)
T2CTL3 P06C	T2 MODE = 0 (RW-0)	T2C1 OUT ENA (RW-0)	T2C2 OUT ENA (RW-0)	T2C1 RST ENA (RW-0)	T2EDGE1 OUT ENA (RW-0)	T2EDGE1 POLARITY (RW-0)	T2EDGE1 RST ENA (RW-0)	T2EDGE1 DET ENA (RW-0)
T2PC1 P06D	—	—	—	—	T2EVT DATA IN (R-0)	T2EVT DATA OUT (RW-0)	T2EVT FUNCTION (RW-0)	T2EVT DATA DIR (RW-0)
T2PC2 P06E	T2IC2/ PWM DATA IN (R-0)	T2IC2/ PWM DATA OUT (RW-0)	T2IC2/ PWM FUNCTION (RW-0)	T2IC2/ PWM DATA DIR (RW-0)	T2IC1/CR DATA IN (R-0)	T2IC1/CR DATA OUT (RW-0)	T2IC1/CR FUNCTION (RW-0)	T2IC1/CR DATA DIR (RW-0)
T2PRI P06F	T2 STEST (RP-0)	T2 PRIORITY (RP-0)	—	—	—	—	—	—

**Figure B-8. Timer 2: Dual Capture Mode**



**Figure B–8. Timer 2: Dual Capture Mode (Concluded)**

Bit #	7	6	5	4	3	2	1	0
T2CNTR MSB P060	Bit 15	T2 COUNTER MSB						Bit 8
T2CNTR LSB P061	Bit 7	T2 COUNTER LSB						Bit 0
T2C MSB P062	Bit 15	COMPARE REGISTER MSB						Bit 8
T2C LSB P063	Bit 7	COMPARE REGISTER LSB						Bit 0
T2CC MSB P064	Bit 15	CAPTURE/COMPARE REGISTER MSB						Bit 8
T2CC LSB P065	Bit 7	CAPTURE/COMPARE REGISTER LSB						Bit 0
T2IC MSB P066	Bit 15	CAPTURE REGISTER 2 MSB						Bit 8
T2IC LSB P067	Bit 7	CAPTURE REGISTER 2 LSB						Bit 0
T2CTL1 P06A	—	—	—	T2 OVRFL INT ENA (RW-0)	T2 OVRFL INT FLAG (RC-0)	T2 INPUT SELECT 1 (RW-0)	T2 INPUT SELECT 0 (RW-0)	T2 SW RESET (S-0)
T2CTL2 P06B	T2EDGE1 INT FLAG (RC-0)	T2EDGE2 INT FLAG (RC-0)	T2C1 INT FLAG (RC-0)	—	—	T2EDGE1 INT ENA (RW-0)	T2EDGE2 INT ENA (RW-0)	T2C1 INT ENA (RW-0)
T2CTL3 P06C	T2 MODE = 1 (RW-0)	—	—	T2C1 RST ENA (RW-0)	T2EDGE2 POLARITY (RW-0)	T2EDGE1 POLARITY (RW-0)	T2EDGE2 DET ENA (RW-0)	T2EDGE1 DET ENA (RW-0)
T2PC1 P06D	—	—	—	—	T2EVT DATA IN (R-0)	T2EVT DATA OUT (RW-0)	T2EVT FUNCTION (RW-0)	T2EVT DATA DIR (RW-0)
T2PC2 P06E	T2IC2/ PWM DATA IN (R-0)	T2IC2/ PWM DATA OUT (RW-0)	T2IC2/ PWM FUNCTION (RW-0)	T2IC2/ PWM DATA DIR (RW-0)	T2IC1/CR DATA IN (R-0)	T2IC1/CR DATA OUT (RW-0)	T2IC1/CR FUNCTION (RW-0)	T2IC1/CR DATA DIR (RW-0)
T2PRI P06F	T2 STEST (RP-0)	T2 PRIORITY (RP-0)	—	—	—	—	—	—

Figure B-9. SCI Block Diagram

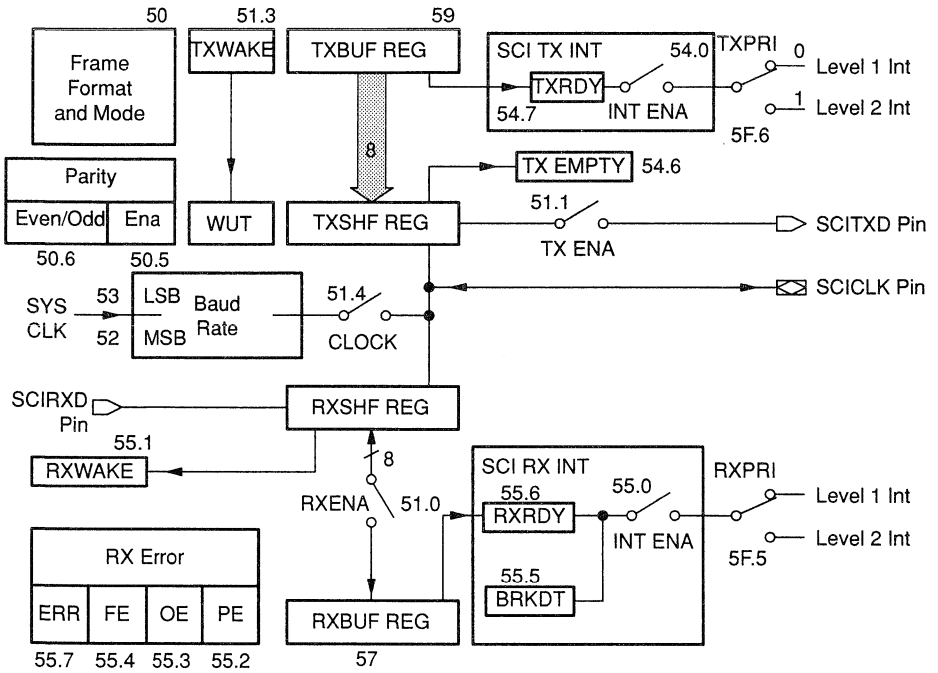
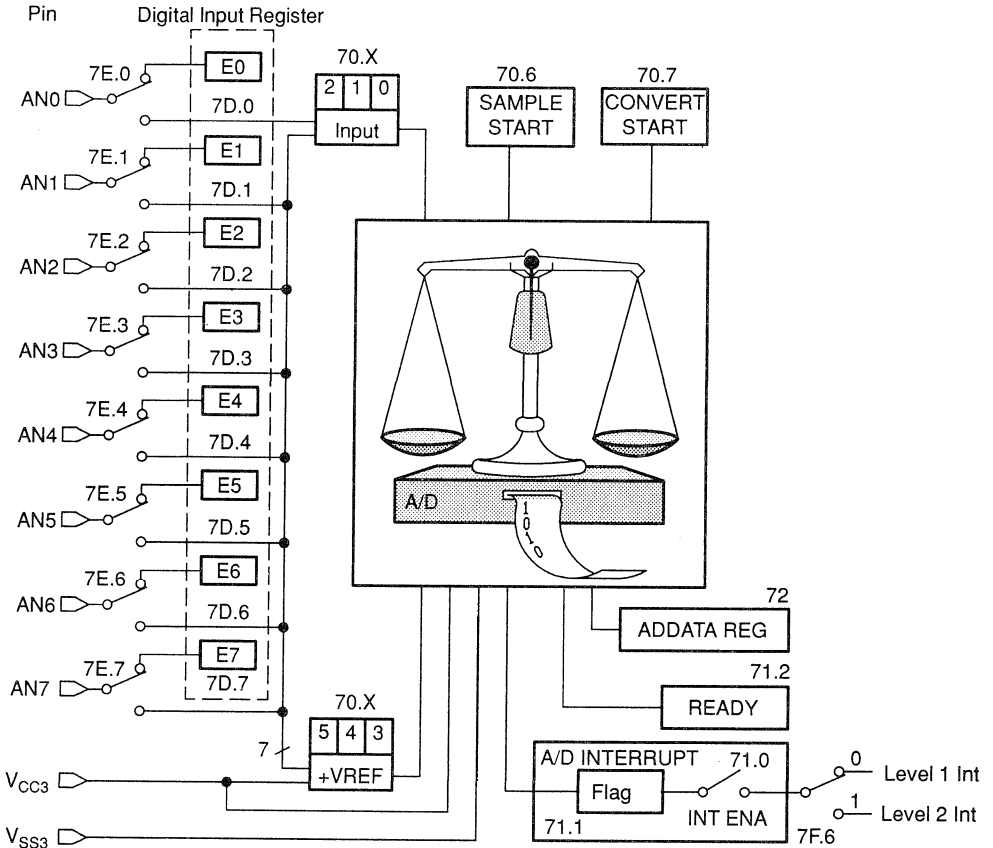




Figure B–9. SCI Block Diagram (Concluded)

Bit #	7	6	5	4	3	2	1	0
SCICCR P050	STOP BITS (RW-0)	EVEN/ODD PARITY (RW-0)	PARITY ENABLE (RW-0)	ASYNC/ ISOSYNC (RW-0)	ADDRESS / IDLE WUP (RW-0)	SCI CHAR2 (RW-0)	SCI CHAR1 (RW-0)	SCI CHAR0 (RW-0)
SCICTL P051	—	—	SCI SW RESET (RW-0)	CLOCK (RW-0)	TXWAKE (RS-0)	SLEEP (RW-0)	TXENA (RW-0)	RXENA (RW-0)
BAUD MSB P052	BAUDF (MSB) (RW-0)	BAUDE (RW-0)	BAUDD (RW-0)	BAUDC (RW-0)	BAUDB (RW-0)	BAUDA (RW-0)	BAUD9 (RW-0)	BAUD8 (RW-0)
BAUD LSB P053	BAUD7 (RW-0)	BAUD6 (RW-0)	BAUD5 (RW-0)	BAUD4 (RW-0)	BAUD3 (RW-0)	BAUD2 (RW-0)	BAUD1 (RW-0)	BAUD0 (LSB) (RW-0)
TXCTL P054	TXRDY (R-1)	TX EMPTY (R-1)	—	—	—	—	—	SCI TX INT ENA (RW-0)
RXCTL P055	RX ERROR (R-0)	RXRDY (R-0)	BRKDT (R-0)	FE (R-0)	OE (R-0)	PE (R-0)	RXWAKE (R-0)	SCI RX INT ENA (RW-0)
RXBUF P057	RXDT7 (R-0)	RXDT6 (R-0)	RXDT5 (R-0)	RXDT4 (R-0)	RXDT3 (R-0)	RXDT2 (R-0)	RXDT1 (R-0)	RXDT0 (R-0)
TXBUF P059	TXDT7 (RW-0)	TXDT6 (RW-0)	TXDT5 (RW-0)	TXDT4 (RW-0)	TXDT3 (RW-0)	TXDT2 (RW-0)	TXDT1 (RW-0)	TXDT0 (RW-0)
SCIPC1 P05D	—	—	—	—	SCICLK DATA IN (R-0)	SCICLK DATA OUT (RW-0)	SCICLK FUNCTION (RW-0)	SCICLK DATA DIR (RW-0)
SCIPC2 P05E	SCITXD DATA IN (R-0)	SCITXD DATA OUT (RW-0)	SCITXD FUNCTION (RW-0)	SCITXD DATA DIR (RW-0)	SCIRXD DATA IN (R-0)	SCIRXD DATA OUT (RW-0)	SCIRXD FUNCTION (RW-0)	SCIRXD DATA DIR (RW-0)
SCIPRI P05F	SCI STEST (RP-0)	SCITX PRIORITY (RP-0)	SCIRX PRIORITY (RP-0)	SCI ESPEN (RP-0)	—	—	—	—

**Figure B-10. Analog-to-Digital Converter Block Diagram**

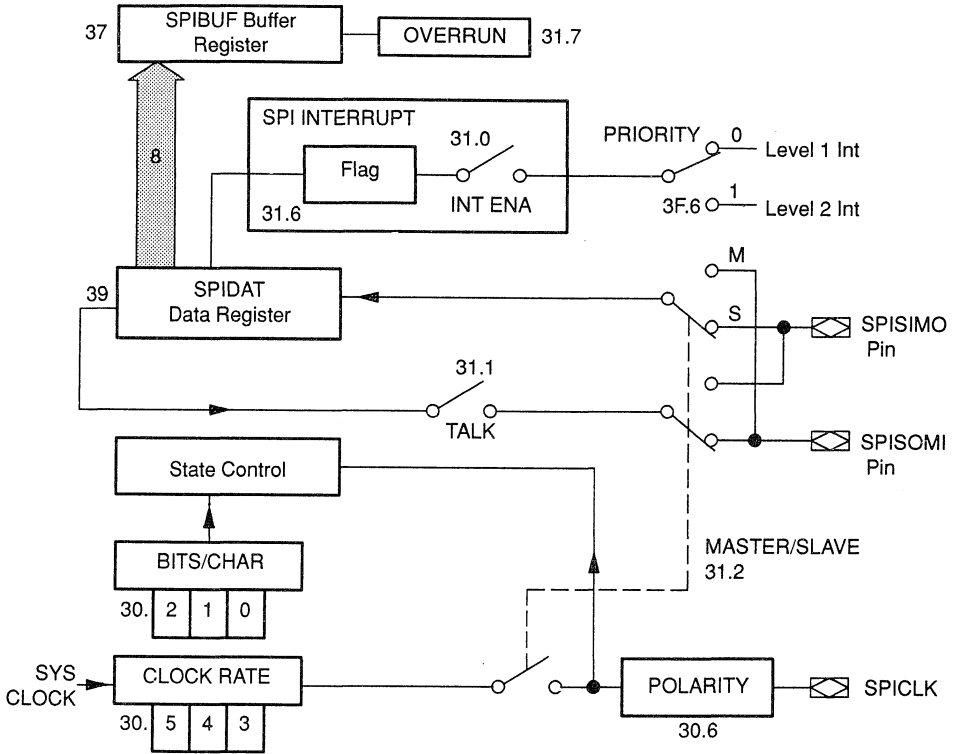


**Figure B-10. Analog-to-Digital Converter Block Diagram (Concluded)**

Bit #	7	6	5	4	3	2	1	0
ADCTL P070	CONVERT START (RW-0)	SAMPLE START (RW-0)	REF VOLT SELECT2 (RW-0)	REF VOLT SELECT1 (RW-0)	REF VOLT SELECT0 (RW-0)	AD INPUT SELECT2 (RW-0)	AD INPUT SELECT1 (RW-0)	AD INPUT SELECT0 (RW-0)
ADSTAT P071	—	—	—	—	—	AD READY (R-1)	AD INT FLAG (RC-0)	AD INT ENA (RW-0)
ADDATA P072	DATA7 (R-0)	DATA6 (R-0)	DATA5 (R-0)	DATA4 (R-0)	DATA3 (R-0)	DATA2 (R-0)	DATA1 (R-0)	DATA0 (R-0)
ADIN P07D	PORT E DATA AN 7 (R-0)	PORT E DATA AN 6 (R-0)	PORT E DATA AN 5 (R-0)	PORT E DATA AN 4 (R-0)	PORT E DATA AN 3 (R-0)	PORT E DATA AN 2 (R-0)	PORT E DATA AN 1 (R-0)	PORT E DATA AN 0 (R-0)
ADENA P07E	PORT E INPUT ENA 7 (RW-0)	PORT E INPUT ENA 6 (RW-0)	PORT E INPUT ENA 5 (RW-0)	PORT E INPUT ENA 4 (RW-0)	PORT E INPUT ENA 3 (RW-0)	PORT E INPUT ENA 2 (RW-0)	PORT E INPUT ENA 1 (RW-0)	PORT E INPUT ENA 0 (RW-0)
ADPRI P07F	AD STEST (RP-0)	AD PRIORITY (RP-0)	AD ESPEN (RP-0)	—	—	—	—	—



Figure B-11. SPI Block Diagram



Bit #	7	6	5	4	3	2	1	0
SPICCR P030	SPI SW RESET (RW-0)	CLOCK POLARITY (RW-0)	SPI BIT RATE2 (RW-0)	SPI BIT RATE1 (RW-0)	SPI BIT RATE0 (RW-0)	SPI CHAR2 (RW-0)	SPI CHAR1 (RW-0)	SPI CHAR0 (RW-0)
SPICTL P031	RECEIVER OVERRUN (R-0)	SPI INT FLAG (R-0)	—	—	—	MASTER / SLAVE (RW-0)	TALK (RW-0)	SPI INT ENA (RW-0)
SPIBUF P037	RCVD7 (R-0)	RCVD6 (R-0)	RCVD5 (R-0)	RCVD4 (R-0)	RCVD3 (R-0)	RCVD2 (R-0)	RCVD1 (R-0)	RCVD0 (R-0)
SPIDAT P039	SDAT7 (RW-0)	SDAT6 (RW-0)	SDAT5 (RW-0)	SDAT4 (RW-0)	SDAT3 (RW-0)	SDAT2 (RW-0)	SDAT1 (RW-0)	SDAT0 (RW-0)
SPIPC1 P03D	—	—	—	—	SPICKL DATA IN (R-0)	SPICKL DATA OUT (RW-0)	SPICKL FUNCTION (RW-0)	SPICKL DATA DIR (RW-0)
SPIPC2 P03E	SPISIMO IN (R-0)	SPISIMO DATA OUT (RW-0)	SPISIMO FUNCTION (RW-0)	SPISIMO DATA DIR (RW-0)	SPISIMO DATA IN (R-0)	SPISIMO DATA OUT (RW-0)	SPISIMO FUNCTION (RW-0)	SPISIMO DATA DIR (RW-0)
SPIPRI P03F	SPI STEST (RP-0)	SPI PRIORITY (RP-0)	SPI ESPEN (RP-0)	—	—	—	—	—

AH

# Character Sets

---

---

---

---

---

The TMS370 Assembler recognizes the ASCII character set listed in Table C-1. Table C-2 lists characters that the assembler does not recognize, but may be recognized and acted upon by other programs. The device service routine for the card reader accepts and stores into the calling program's buffer all the characters listed.

**Table C-1. ASCII Character Set**

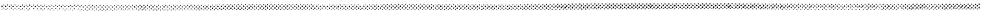
ASCII Character Set (7-Bit Code)										
L	S	M	0	1	2	3	4	5	6	7
		N	(0)	(16)	(32)	(48)	(64)	(80)	(96)	(112)
	0		NUL	DLE	SP	0	@	P	'	p
	1		SOH	DC1	!	1	A	Q	a	q
	2		STX	DC2	"	2	B	R	b	r
	3		ETX	DC3	#	3	C	S	c	s
	4		EOT	DC4	\$	4	D	T	d	t
	5		ENQ	NAK	%	5	E	U	e	u
	6		ACK	SYN	&	6	F	V	f	v
	7		BEL	ETB	'	7	G	W	g	w
	8		BS	CAN	(	8	H	X	h	x
	9		HT	EM	)	9	I	Y	i	y
A			LF	SUB	*	:	J	Z	j	z
B			VT	ESC	+	;	K	[	k	{
C			FF	FS	,	<	L	\	l	
D			CR	GS	-	=	M	]	m	}
E			SO	RS	.	>	N	^	n	~
F			SI	US	/	?	O	_	o	DEL

**Note:** To obtain decimal value add decimal MSN to decimal LSN.



**Table C-2. Control Characters**

Hex Value	Decimal Value	Character
00	0	NUL
01	1	SOH
02	2	STX
03	3	ETX
04	4	EOT
05	5	ENQ
06	6	ACK
07	7	BEL
08	8	BS
09	9	HT
0A	10	LF
0B	11	VT
0C	12	FF
0D	13	CR
0E	14	SO
0F	15	SI
10	16	DLE
11	17	DC1
12	18	DC2
13	19	DC3
14	20	DC4
15	21	NAK
16	22	SYN
17	23	ETB
18	24	CAN
19	25	EM
1A	26	SUB
1B	27	ESC
1C	28	FS
1D	29	GS
1E	30	RS
1F	31	US
7F	32	DEL





# Opcode/Instruction Cross Reference

---

---

---

Table D-1 (on the following pages) provides an opcode-to-instruction cross reference of all 73 mnemonics and 245 opcodes of the TMS370 instruction set. To check the instruction of a known opcode, locate the left (high) digit across the top or bottom of the table, then find the right (low) digit along the side of the table. The intersection contains the instruction mnemonic, operands, and byte/cycle particular to that opcode. Some opcodes, such as B0, are shared by two instructions, in which case both mnemonics are shown along with the byte/cycles count.



Table D-1. TMS370 Family Opcode/Instruction Map

	0	1	2	3	4	5	6	7	MSN	9	A	B	C	D	E	F
JMP	ra 2/7								MOV Ps,A 2/8					MOV A,Rd 2/7	TRAP 15 1/14	LDST n 2/6
JN	ra 2/5	MOV A,Pd 2/8				MOV B,Pd 2/8		MOV Rs,Pd 3/10		MOV Ps,B 2/7				MOV B,Rd 2/7	TRAP 14 1/14	MOV n(SP),A 2/7
JZ	ra 2/5	MOV Rs,A #n,A 2/7	MOV #n,A 2/6	MOV Rs,Rd 2/7	MOV #n,B 2/6	MOV #n,B 2/6	MOV B,A 1/8	MOV #n,Rd 3/8			MOV Ps,Rd 3/10	DEC A 1/8	DEC B 1/8	DEC Rn 2/6	TRAP 13 1/14	MOV A,n(SP) 2/7
JC	ra 2/5	AND Rs,A #n,A 2/7	AND #n,A 2/6	AND Rs,Rd 2/7	AND #n,B 2/6	AND #n,B 2/6	AND B,A 1/8	AND #n,Rd 3/8		AND B,Pd 2/9	AND #n,Pd 3/10	INC A 1/8	INC B 1/8	INC Rn 2/6	TRAP 12 1/14	CMP n(SP),A 2/8
JP	ra 2/5	OR Rs,A #n,A 2/7	OR #n,A 2/6	OR Rs,Rd 2/7	OR #n,B 2/6	OR #n,B 2/6	OR B,A 1/8	OR #n,Rd 3/8		OR B,Pd 2/9	OR #n,Pd 3/10	INV A 1/8	INV B 1/8	INV Rn 2/6	TRAP 11 1/14	extend inst,2 opcodes
JPZ	ra 2/5	XOR Rs,A #n,A 2/7	XOR #n,A 2/6	XOR Rs,Rd 2/7	XOR #n,B 2/6	XOR #n,B 2/6	XOR B,A 1/8	XOR #n,Rd 3/8		XOR B,Pd 2/9	XOR #n,Pd 3/10	CLR A 1/8	CLR B 1/8	CLR Rn 2/6	TRAP 10 1/14	
JNZ	ra 2/5	BTJO Rs,A #n,A 3/8	BTJO #n,A 3/8	BTJO Rs,B 3/9	BTJO #n,B 3/8	BTJO B,A 2/10	BTJO B,A 2/10	BTJO #n,Rd 4/10		BTJO B,Pd 3/10	BTJO #n,Pd 4/11	XCHB A 1/10	XCHB A / TST B 1/10	XCHB Rn 2/8	TRAP 9 1/14	IDLE 1/6
JNC	ra 2/5	BTJZ Rs,A #n,A 3/8	BTJZ #n,A 3/8	BTJZ Rs,Rd 3/9	BTJZ #n,B 3/8	BTJZ B,A 2/10	BTJZ B,A 2/10	BTJZ #n,Rd 4/10		BTJZ B,Pd 3/10	BTJZ #n,Pd 4/11	SWAP A 1/11	SWAP B 1/11	SWAP Rn 2/9	TRAP 8 1/14	MOV #n,Pd 3/10
JV	ra 2/5	ADD Rs,A #n,A 2/6	ADD #n,A 2/6	ADD Rs,Rd 2/7	ADD #n,B 2/6	ADD #n,B 2/6	ADD B,A 1/8	ADD #n,Rd 3/8		MOVW #16(B),Rs,Rd 3/12	MOVW #16(B),Rd 4/15	PUSH A 1/9	PUSH B 1/9	PUSH Rs 2/7	TRAP 7 1/14	SETC 1/7
JL	ra 2/5	ADC Rs,A #n,A 2/7	ADC #n,A 2/6	ADC Rs,B 2/7	ADC #n,B 2/6	ADC B,A 1/8	ADC B,A 1/8	ADC #n,Rd 3/8		JMPL @Rd 2/8	JMPL lab(B) 3/11	POP A 1/9	POP B 1/9	POP Rn 2/7	TRAP 6 1/14	RTS 1/9
JLE	ra 2/5	SUB Rs,A #n,A 2/7	SUB #n,A 2/6	SUB Rs,Rd 2/7	SUB #n,B 2/6	SUB B,A 1/8	SUB B,A 1/8	SUB #n,Rd 3/8		MOV @Rs,A 2/9	MOV lab(A),A 3/12	DJNZ A,ra 2/10	DJNZ B,ra 2/10	DJNZ Rn,ra 3/8	TRAP 5 1/14	RTI 1/12
JHS	ra 2/5	SBB Rs,A #n,A 2/7	SBB #n,A 2/6	SBB Rs,Rd 2/7	SBB #n,B 2/6	SBB B,A 1/8	SBB B,A 1/8	SBB #n,Rd 3/8		MOV A,@Rd 2/9	MOV A,lab(B) 3/12	COMPL A 1/8	COMPL B 1/8	COMPL Rn 2/6	TRAP 4 1/14	PUSH ST 1/8

L S N

Table D-1. TMS370 Family Opcode/Instruction Map (Concluded)

		MSN															
		0	1	2	3	4	5	6	7	8	9	A	B	C	D	E	F
C	JNV	ra	MPY Rs,A	MPY #n,A	MPY Rs,B	MPY Rs,Rd	MPY #n,B	MPY B,A	MPY #n,Rs	BR lab	BR @Rd	BR lab(B)	RR A	RR B	RR Rn	TRAP 3	POP ST
		2/5	2/46	2/45	2/46	3/48	2/45	1/47	3/47	3/9	2/8	3/11	1/8	1/8	2/6	1/4	1/8
D	JGE	ra	CMP Rs,A	CMP #n,A	CMP Rs,B	CMP Rs,Rd	CMP #n,B	CMP B,A	CMP #n,Rd	CMP lab,A	CMP @Rs,A	CMP lab(B),A	RRC A	RRC B	RRC Rn	TRAP 2	LDSP
		2/5	2/7	2/6	2/7	3/9	2/6	1/8	3/8	3/11	2/10	3/13	1/8	1/8	2/6	1/4	1/7
E	JG	ra	DAC Rs,A	DAC #n,A	DAC Rs,B	DAC Rs,Rd	DAC #n,B	DAC B,A	DAC #n,Rd	CALL lab	CALL @Rd	CALL lab(B)	RL A	RL B	RL Rn	TRAP 1	STSP
		2/5	2/9	2/8	2/9	3/11	2/8	1/10	3/10	3/13	2/12	3/15	1/8	1/8	2/6	1/4	1/8
F	JLO	ra	DSB Rs,A	DSB #n,A	DSB Rs,B	DSB Rs,Rd	DSB #n,B	DSB B,A	DSB #n,Rd	CALLR lab	CALLR @Rd	CALLR lab(B)	RLC A	RLC B	RLC Rn	TRAP 0	NOP
		2/5	2/9	2/8	2/9	3/11	2/8	1/10	3/10	3/15	2/14	3/17	1/8	1/8	2/6	1/4	1/7
		Second byte of two-byte instructions (F4xx):															
														F4	8	MOVW n(Rn)	DIV Rn,A
														F4	9	JMPL n(Rn)	
														F4	A	MOV n(Rn),A	
														F4	B	MOV A,n(Rn)	
														F4	C	BR n(Rn)	
														F4	D	CMP n(Rn),A	
														F4	E	CALL n(Rn)	
														F4	F	CALLR n(Rn)	

ra - relative address  
Rn - Register  
Rs - Register containing source byte  
Rd - Register containing destination byte  
Ps - Peripheral register containing source byte  
Pd - Peripheral register containing destination byte  
Pn - Peripheral register  
n - Immediate 8-bit number  
lab - 16-bit label

**Note:** All conditional jumps (opcodes 01-0F), BTJO, BTJZ, and DJNZ instructions use two additional cycles if the branch is taken. The BTJO, BTJZ, and DJNZ instructions have a relative address as the last operand.





# Instruction/Opcode Cross Reference & Bus Activity Table

---

---

---

This appendix contains both an instruction-to-opcode cross reference and an instruction bus activity table. The bus activity table specifies the cycle-by-cycle actions of a given instruction.

## E.1 Instruction/Opcode Cross Reference

Table E-1 provides an instruction-to-opcode cross reference of all 73 mnemonics and 246 opcodes of the TMS370 instruction set. The columns are grouped according to addressing modes.

**Table E-1. TMS370 Family Instruction/Opcode Set**

	GENERAL														EXTENDED				Other				
	A	B	Rn	A,B	B,A	Rn, A	#n, A	Rn, B	#n, B	Rn, Rn	#n, Rn	A, Rn	B, Rn	A, Pn	B, Pn	Pn, B	#n, Pn	†		‡	§	¶	»
ADC					69	19	29	39	59	49	79												
ADD					68	18	28	38	58	48	78												
AND					63	13	23	33	53	43	73			83	93		A3						
BR																		8C	AC	9C	EC		
BTJO					66	16	26	36	56	46	76			86	A6		96						
BTJZ					67	17	27	37	57	47	77			87	A7		97						
CALL																		8E	9E	AE	EE		
CALLR																		8F	9F	AF	EF		
CLR	B5	C5	D5																				
CLRC																							BO
CMP					6D	1D	2D	3D	5D	4D	7D							8D	AD	9D	ED		F3
CMPBIT																							75,A5
COMPL	BB	CB	DB																				
DAC					6E	1E	2E	3E	5E	4E	7E												
DEC	B2	C2	D2																				
DINT																							F0 00
DIV																							F4 F8
DJNZ	BA	CA	DA																				
DSB					6F	1F	2F	3F	5F	4F	7F												
EINT																							F0 0C
EINTH																							F0 04
EINTL																							F0 08
IDLE																							F6
INC	B3	C3	D3																				
INV	B4	C4	D4																				
JBIT0																							77,A7
JBIT1																							76,A6
JMP																							00
JMPL																		89	A9	99	E9		
JC																							03
JEQ/JZ																							02
JG																							0E
JGE																							0D
JHS																							0B
JL																							09
JLE																							0A
JLO																							0F
JN																							01
JNC																							07
JNE/JNZ																							06
JNV																							0C
JP																							04
JPZ																							05
JV																							08
LDSP																							FD

† Direct ((label) → (A))  
‡ Indexed ((label + (B)) → (A))  
§ Indirect ((Rn-1: Rn) → (A))  
¶ Offset Indirect (dual opcode instruction, the first of which is F4) ((n + (Rn - 1: Rn)) → (A))  
» Single opcode instructions that do not qualify as a General or Extended addressing mode, and dual opcode instructions that do not qualify as an Offset Indirect addressing mode.

A  
H

**Table E-1. TMS370 Family Instruction/Opcode Set (Concluded)**

	GENERAL																EXTENDED				Other			
	A	B	Rn	A,B	B,A	Rn, A	#n, A	Rn, B	#n, B	Rn, Rn	#n, Rn	A, Rn	B, Rn	A, Pn	Pn, A	B, Pn	Pn, B	#n, Pn	†	‡		§	¶	»
LDST																								F0
MOV				C0	62	12	22	32	52	42	72	D0	D1	21	80	51	91	F7	8B	AA	9A	EA	EA	
MOVW																			88	A8	98	E8		
MPY				6C	1C	2C	3C	5C	4C	7C														
NOP																								
OR				64	14	24	34	54	44	74			84		94		A4							FF
POP	B9	C9	D9																					FC
PUSH	B8	C8	D8																					FB
RL	BE	CE	DE																					
RLC	BF	CF	DF																					
RR	BC	CC	DC																					
RRC	BD	CD	DD																					
RTI																								FA
RTS																								F9
SBB				6B	1B	2B	3B	5B	4B	7B														
SBIT0																								J
SBIT1																								J
SETC																								F8
STSP																								FE
SUB				6A	1A	2A	3A	5A	4A	7A														
SWAP	B7	C7	D7																					
TRAP																								**
TST	B0	C6																						
XCHB	B6	C6	D6																					
XOR				65	15	25	35	55	45	75			85		95		A5							

- † Direct
- ‡ Indexed
- § Indirect
- ¶ Offset Indirect (dual opcode instruction, the first of which is F4)
- » Unless otherwise indicated, includes single opcode instructions that do not qualify as a General or Extended addressing mode, and dual opcode instructions that do not qualify as an Offset Indirect addressing mode.
- || The MOV instruction also includes the following options and their opcodes: Rn,Pn {71}; Pn,Rn {A2}; A,label(B) {AB}; A,n(SP) {F2}; A,n(Rn) {F4 EB}; label,A {8A}; n(SP),A {F1}
- J The SBIT0 instruction consists of the following options and their opcodes; Rname {73}; Pname {A3}
- J The SBIT1 instruction consists of the following options and their opcodes; Rname {74}; Pname {A4}
- \*\* The TRAP instruction consists of 15 options using operands 0 through 15 with opcodes EF through E0 respectively.



## E.2 Bus Activity Tables

The TMS370 family employs a microcoded instruction set. Microcode breaks down each instruction into microcode states and executes a mini-program for each instruction using these states. Each microcode state lasts for one internal clock cycle and includes provisions for conditional jumps, branching, and control of internal CPU operations. In order to increase efficiency and variety, each instruction can use sections of common microcode states (similar to subroutines).

The tables in this section provide a cycle by cycle accounting for each of the 246 instruction and operand combinations for the TMS370 family micro-controllers. Each line consists of the opcode value, the mnemonic and operands, and finally a summary of all the cycles. The two letter abbreviation is explained in the legend on the following page and at the end the tables.

The table gives the minimum time for each instruction by showing the number of internal states. Each state lasts for four CLKIN or crystal periods so each state represents 200 ns for a crystal running at 20 MHz. This time may increase if the application uses the autowait mode, peripheral autowait mode or wait pin. **The wait modes affect only the '<<' cycles which access external memory.**

The abbreviations break into two groups. The first group generates valid external bus cycles when accessing external memory. Internal memory accesses do not give valid external bus cycles. The second group operates only internally and does not generate valid bus cycles.

The instructions are typically expressed in this format:

OPCODE INSTR O1[,O2][,O3]

Operands are always read in increasing address order. This distinction is especially important for the MOV Rn,Pn and the MOV Pn,Rn instructions where the operands are in reversed address order. A and B are implied operands and do not require additional bytes.





## E.2.1 Possible Bus Cycles

OP – Opcode read	Opcode fetch, $\overline{OCF}$ , active during this cycle.
PO – Pseudo operand read	Operand is read then discarded, PC does not advance. Operand usually becomes an opcode on next instruction cycle.
$On$ – Operand read	Read instruction's operands. (n=operand order in instruction)
PF – Prefix byte	First byte of a two byte opcode. $\overline{OCF}$ active during this cycle and not during next OP cycle. Always 0F4h.
Pr – Peripheral read	Read of 1000h–10FFh. The external reads are affected by PF AUTO WAIT
Pw – Peripheral write	Write to 1000h–10FFh. The external writes are affected by PF AUTO WAIT
Lr – Long read	General long read, Range of 0–0FFFFh
Lw – Long write	General long write, Range of 0–0FFFFh
Vr – Vector read	Reads vectors in Trap Table (7FC0–7FDF)
<< – Continuation	Finish memory access, nominal one cycle. If accessing external memory, it could be two or more cycles by using Autowait, PF wait or external Wait signals. Only cycle type affected by wait modes.

## E.2.2 Internal Cycles

IC – Internal cycle	Indeterminent internal operation
RJ – Relative jump	Add these if jump is taken; takes two cycles so they always comes in pairs.
SH – Stack push,	$(SP)+1 \rightarrow (SP); n \rightarrow ((SP))$
SP – Stack pop	$((SP)) \rightarrow n; (SP)-1 \rightarrow (SP)$
Sr – Stack read	$((SP))$ usually dummy cycle
Ar – Register A read	1 cycle register accesses
Br – Register B read	1 cycle register accesses
Rr – Register read	1 cycle register accesses
Aw – Register A write	1 cycle register accesses
Bw – Register B write	1 cycle register accesses
Rw – Register write	1 cycle register accesses

Table E-2. Bus Activity Tables

code	Instruction	1	2	3	4	5	6	7	8	9	10	11	12	13	14	15	16	17	18	19	20	21	22
29	ADC #n,A	OC	<<	O1	<<	Ar	Aw	Aw															
59	ADC #n,B	OC	<<	O1	<<	Br	Bw	Bw															
79	ADC #n,Rn	OC	<<	O1	<<	OC	O2																
69	ADC B,A	OC	<<	PO	<<	Br	Aw	Ar	Rw														
19	ADC Rn,A	OC	<<	O1	<<	Rr	Br	Ar															
49	ADC Rn,B	OC	<<	O1	<<	Rr	Bw	Ar															
28	ADC Rs,Rd	OC	<<	O1	<<	OC	O2																
58	ADD #n,A	OC	<<	O1	<<	Ar	Aw																
78	ADD #n,B	OC	<<	O1	<<	Br	Bw																
68	ADD B,A	OC	<<	PO	<<	OC	O2																
18	ADD Rn,A	OC	<<	O1	<<	Rr	Ar	Ar	Rw														
38	ADD Rn,B	OC	<<	O1	<<	Rr	Bw	Ar															
48	ADD Rs,Rd	OC	<<	O1	<<	OC	O2																
23	AND #n,A	OC	<<	O1	<<	Ar	Aw																
53	AND #n,B	OC	<<	O1	<<	Br	Bw																
A3	AND #n,Pd	OC	<<	O1	<<	OC	O2																
73	AND #n,Rn	OC	<<	O1	<<	OC	O2																
83	AND A,Pn	OC	<<	O1	<<	Ar	Pw																
63	AND B,A	OC	<<	PO	<<	OC	O2																
93	AND B,Pn	OC	<<	O1	<<	Ar	Pw																
13	AND Rn,A	OC	<<	O1	<<	Rr	Ar	Ar	Rw														
33	AND Rn,B	OC	<<	O1	<<	Rr	Bw	Ar															
43	AND Rs,Rd	OC	<<	O1	<<	OC	O2																
9C	BR @Rd	OC	<<	O1	<<	Rr	Rr																
8C	BR lab	OC	<<	O1	<<	Rr	Bw																
AC	BR lab(B)	OC	<<	O1	<<	OC	O2																
EC	BR n(Rn)	PF	<<	OC	<<	OC	O2																
26	BTJO #n,A,ra	OC	<<	O1	<<	Ar	IC	IC	IC	IC	IC	IC											
56	BTJO #n,B,ra	OC	<<	O1	<<	Br	IC	IC	IC	IC	IC	IC											
A6	BTJO #n,Pd,ra	OC	<<	O1	<<	OC	O2																
76	BTJO #n,Rn,ra	OC	<<	O1	<<	OC	O2																
86	BTJO A,Pn,ra	OC	<<	O1	<<	Ar	IC	IC	IC	IC	IC	IC											
66	BTJO B,A,ra	OC	<<	PO	<<	OC	O2																
96	BTJO B,Pn,ra	OC	<<	O1	<<	Ar	IC	IC	IC	IC	IC	IC											
16	BTJO Rn,A,ra	OC	<<	O1	<<	Rr	Ar	Ar	IC	IC	IC	IC											
36	BTJO Rn,B,ra	OC	<<	O1	<<	Rr	Bw	Ar	IC	IC	IC	IC											
46	BTJO Rs,Rd,ra	OC	<<	O1	<<	OC	O2																
	code Instruction	1	2	3	4	5	6	7	8	9	10	11	12	13	14	15	16	17	18	19	20	21	22

Table E-2. Bus Activity Tables (Continued)

code	Instruction	1	2	3	4	5	6	7	8	9	10	11	12	13	14	15	16	17	18	19	20	21	22
27	BTJZ #n,A,ra	OC	<<	O1	Ar	IC	O2	O2	<<	RJ	RJ												
57	BTJZ #n,B,ra	OC	<<	O1	Br	IC	O2	O2	<<	RJ	RJ												
A7	BTJZ #n,Pd,ra	OC	<<	O1	O2	<<	O2	Pr	IC	O3	<<	<<	RJ										
77	BTJZ #n,Rn,ra	OC	<<	O1	Ar	O2	Ar	<<	IC	O3	<<	<<	RJ										
87	BTJZ A,Pn,ra	OC	<<	PO	Ar	Pr	IC	<<	IC	O2	<<	<<	RJ										
67	BTJZ B,A,ra	OC	<<	O1	Ar	Pr	IC	<<	IC	O2	<<	<<	RJ										
97	BTJZ B,Pn,ra	OC	<<	O1	Ar	Pr	IC	<<	IC	O2	<<	<<	RJ										
17	BTJZ Rn,A,ra	OC	<<	O1	Ar	Pr	IC	<<	IC	O2	<<	<<	RJ										
37	BTJZ Rn,B,ra	OC	<<	O1	Ar	Pr	IC	<<	IC	O2	<<	<<	RJ										
47	BTJZ Rs,Rd,ra	OC	<<	O1	Ar	Pr	O2	Ar	IC	O2	<<	<<	RJ										
9E	CALL @Rd	OC	<<	O1	Ar	Pr	IC	<<	Rr	IC	O3	<<	IC										
8E	CALL lab(B)	OC	<<	O1	Ar	Pr	IC	<<	SH	IC	SH	IC	IC										
EE	CALL n(Rn)	OC	<<	O1	Ar	Pr	IC	<<	IC	IC	IC	SH	IC										
9F	CALLR @Rd	OC	<<	O1	Ar	Pr	IC	O1	<<	O2	<<	IC	SH										
8F	CALLR lab	OC	<<	O1	Ar	Pr	IC	Rr	IC	IC	SH	IC	IC										
AF	CALLR lab(B)	OC	<<	O1	Ar	O2	<<	<<	IC	IC	SH	IC	SH										
EF	CALLR n(Rn)	PF	<<	OC	Ar	O2	<<	IC	IC	IC	IC	SH	IC										
B5	CLR A	OC	<<	PO	Ar	IC	IC	IC	IC	IC	IC	IC	IC										
C5	CLR B	OC	<<	PO	Ar	IC	IC	IC	IC	IC	IC	IC	IC										
D5	CLR Rn	OC	<<	PO	Ar	Pr	IC	IC	IC	IC	IC	IC	IC										
B0	CLRC	OC	<<	PO	Ar	Rw	IC	IC	Ar	Aw													
F3	CMP n(SP),A	OC	<<	O1	Ar	IC	IC	IC	Ar	IC													
2D	CMP #n,A	OC	<<	O1	Ar	IC	IC	IC	Ar	IC													
5D	CMP #n,B	OC	<<	O1	Ar	IC	IC	IC	Ar	IC													
7D	CMP #n,Rn	OC	<<	O1	Ar	O2	<<	Ar	IC	Ar	IC												
9D	CMP @Rd,A	OC	<<	O1	Ar	Pr	IC	Ar	IC	Ar	IC												
6D	CMP B,A	OC	<<	PO	Ar	Pr	IC	Ar	IC	Ar	IC												
AD	CMP lab(B),A	OC	<<	PO	Ar	Pr	IC	Ar	IC	Ar	IC												
8D	CMP lab,A	OC	<<	O1	Ar	O2	<<	Ar	IC	Ar	IC												
ED	CMP n(Rn),A	PF	<<	OC	Ar	O2	<<	IC	IC	Ar	<<	<<	Ar										
1D	CMP Rn,A	OC	<<	OC	Ar	Pr	IC	IC	Ar	IC	<<	<<	Rr										
3D	CMP Rn,B	OC	<<	O1	Ar	Pr	IC	Ar	IC	Ar	IC												
4D	CMP Rs,Rd	OC	<<	O1	Ar	Pr	O2	Ar	IC	Ar	IC												
A5	CMPBIT Pname	OC	<<	O1	Ar	Pr	O2	Ar	IC	Ar	IC												
75	CMPBIT Rname	OC	<<	O1	Ar	O2	<<	Pr	<<	Pw	<<												
BB	COMPL A	OC	<<	PO	Ar	IC	IC	IC	Rw	Aw													
CB	COMPL B	OC	<<	PO	Ar	IC	IC	IC	Aw	Aw													
DB	COMPL Rn	OC	<<	PO	Ar	IC	IC	IC	Bw	Bw													
	code instruction	1	2	3	4	5	6	7	8	9	10	11	12	13	14	15	16	17	18	19	20	21	22





Table E-2. Bus Activity Tables (Continued)

code	Instruction	1	2	3	4	5	6	7	8	9	10	11	12	13	14	15	16	17	18	19	20	21	22
99	JMPL @Rd	OC	<<	O1	<<	Rr	Rr	IC	IC	IC													
89	JMPL lab	OC	<<	O1	<<	O2	<<	IC	IC	IC													
A9	JMPL lab(B)	OC	<<	O1	<<	O2	<<	Br	IC	IC													
E9	JMPL r(Rn)	PF	<<	OC	<<	IC	IC	O1	IC	O2	<<	Rr	IC	IC	IC	IC							
FD	LDSP	OC	<<	PO	<<	Sr	Br	IC	<<														
F0	LDST	OC	<<	O1	<<	IC	IC	IC															
F2	MOV A,n(SP)	OC	<<	O1	<<	IC	Ar	Rw															
F1	MOV n(SP),A	OC	<<	O1	<<	IC	Ar	Aw															
22	MOV #n,A	OC	<<	O1	<<	Ar	Aw																
52	MOV #n,B	OC	<<	O1	<<	Br	Bw																
F7	MOV #n,Pd	OC	<<	O1	<<	IC	O2	<<	IC	Pw	<<												
72	MOV #n,Rn	OC	<<	O1	<<	O2	<<	Rr	Lr	Aw													
9A	MOV @Rd,A	OC	<<	O1	<<	Rr	Ar	IC	Lr	Aw													
9B	MOV A,@Rd	OC	<<	O1	<<	Rr	Ar	IC	Lr	Aw													
C0	MOV A,B	OC	<<	O1	<<	Br	Ar	IC	Ar	Bw													
8B	MOV A,lab	OC	<<	O1	<<	O2	<<	IC	Ar	Lw	<<												
AB	MOV A,lab(B)	OC	<<	O1	<<	O2	<<	Br	IC	Ar	<<												
EB	MOV A,n(Rn)	PF	<<	OC	<<	IC	IC	O1	IC	O2	<<	Rr	IC	IC	IC	Ar	Lw	<<					
21	MOV A,Pn	OC	<<	O1	<<	Ar	IC	Pw	<<														
D0	MOV A,Rn	OC	<<	O1	<<	Rr	Ar	Rw	<<														
62	MOV B,A	OC	<<	PO	<<	Br	IC	Ar	Aw														
51	MOV B,Pn	OC	<<	O1	<<	Br	IC	Pw	<<														
D1	MOV B,Rn	OC	<<	O1	<<	Rr	Br	IC	Pw	<<													
AA	MOV lab(B),A	OC	<<	O1	<<	O2	<<	Br	IC	Lr	Lr	<<	Aw										
8A	MOV lab,A	OC	<<	O1	<<	O2	<<	Br	IC	Lr	Aw	<<											
EA	MOV n(Rn),A	PF	<<	OC	<<	IC	IC	O1	IC	O2	<<	Rr	IC	IC	IC	LR	<<	Aw					
80	MOV Pn,A	OC	<<	O1	<<	Ar	Pt	<<	Aw														
91	MOV Pn,B	OC	<<	O1	<<	Br	Pt	<<	Bw														
A2	MOV Ps,Rd	OC	<<	O2r	<<	O1p	<<	Pt	<<	IC	Rw												
12	MOV Rn,A	OC	<<	O1	<<	Rr	Ar	Aw	<<														
32	MOV Rn,B	OC	<<	O1	<<	Rr	Br	Bw	<<														
71	MOV Rs,Pd	OC	<<	O2p	<<	O1r	<<	Rr	IC	Pw	<<												
42	MOV Rs,Rd	OC	<<	O1	<<	Rr	O2	<<	Br	IC	<<												
A8	MOVW #16n(B),Rd	OC	<<	O1	<<	O2	<<	Br	IC	IC	O3	IC	Rw	IC	Rw								
88	MOVW #16n,Rd	OC	<<	O1	<<	O2	<<	Br	IC	IC	O3	IC	Rw	IC	Rw								
E8	MOVW #n(Rs),Rd	PF	<<	OC	<<	IC	IC	O1	IC	O2	<<	Rr	IC	IC	IC	O3	<<	IC	RW	IC	RW		
98	MOVW Rs,Rd	OC	<<	O1	<<	Rr	O2	<<	Br	IC	Rw	IC	Rw	IC	IC	O3	<<	IC	RW	IC	RW		
2C	MPY #n,A	OC	<<	O1	<<	Ar	<<	Ar	<<														
5C	MPY #n,B	OC	<<	O1	<<	Br	<<	Br	<<														
7C	MPY #n,Rn	OC	<<	O1	<<	O2	<<	Rr	<<														
6C	MPY B,A	OC	<<	PO	<<	Br	IC	Ar	<<														
1C	MPY Rn,A	OC	<<	O1	<<	Rr	Ar	Br	IC	IC	Br	IC	Aw	Aw									
3C	MPY Rn,B	OC	<<	O1	<<	Rr	Br	IC	IC	IC	Br	IC	Aw	Aw									
4C	MPY Rs,Rd	OC	<<	O1	<<	Rr	O2	<<	Br	IC	Rw	IC	Rw	IC	IC	O3	<<	IC	RW	IC	RW		
FF	NOP	OC	<<	PO	<<	Sr	Br	IC	<<														
	code Instruction	1	2	3	4	5	6	7	8	9	10	11	12	13	14	15	16	17	18	19	20	21	22



**Table E-2. Bus Activity Tables (Continued)**

code	Instruction	1	2	3	4	5	6	7	8	9	10	11	12	13	14	15	16	17	18	19	20	21	22
24	OR #n,A	OC	<<	O1	<<	Ar	Aw																
54	OR #n,B	OC	<<	O1	<<	Br	Bw																
A4	OR #n,Pd	OC	<<	O2	<<	O2	<<																
74	OR #n,Rn	OC	<<	O2	<<	O2	<<	Pr	Rr	Pw	<<												
84	OR A,Pn	OC	<<	O1	<<	Ar	Ar	<<															
64	OR B,A	OC	<<	PO	<<	Br	Pr	<<															
94	OR B,Pn	OC	<<	O1	<<	Br	Pr	<<															
14	OR Rn,A	OC	<<	O1	<<	Ar	Ar	<<															
34	OR Rn,B	OC	<<	O1	<<	Ar	Ar	<<															
44	OR Rs,Rd	OC	<<	O1	<<	Rr	O2	<<															
B9	POP A	OC	<<	PO	<<	Ar	IC	IC															
C9	POP B	OC	<<	PO	<<	Br	IC	IC															
D9	POP Rn	OC	<<	O1	<<	Rr	SP	Rw															
FC	POP ST	OC	<<	PO	<<	SP	Br	IC															
B8	PUSH A	OC	<<	PO	<<	Ar	IC	IC															
C8	PUSH B	OC	<<	PO	<<	Br	IC	IC															
D8	PUSH Rn	OC	<<	O1	<<	Rr	IC	SH															
FB	PUSH ST	OC	<<	PO	<<	Sr	Br	IC															
BE	RL A	OC	<<	PO	<<	Ar	IC	IC															
CE	RL B	OC	<<	PO	<<	Br	IC	IC															
DE	RL Rn	OC	<<	O1	<<	Rr	Rw																
BF	RLC A	OC	<<	PO	<<	Ar	IC	IC															
CF	RLC B	OC	<<	PO	<<	Br	IC	IC															
DF	RLC Rn	OC	<<	O1	<<	Rr	Rw																
BC	RR A	OC	<<	PO	<<	Ar	IC	IC															
CC	RR B	OC	<<	PO	<<	Br	IC	IC															
DC	RR Rn	OC	<<	O1	<<	Rr	Rw																
BD	RRR A	OC	<<	PO	<<	Ar	IC	IC															
CD	RRR B	OC	<<	PO	<<	Br	IC	IC															
DD	RRR Rn	OC	<<	PO	<<	Rr	Rw																
FA	RTI	OC	<<	PO	<<	SP	Br	IC															
F9	RTS	OC	<<	PO	<<	SP	Br	IC															
2B	SBB #n,A	OC	<<	O1	<<	Ar	Aw																
5B	SBB #n,B	OC	<<	O1	<<	Br	Bw																
7B	SBB #n,Rn	OC	<<	O1	<<	O2	<<	Rr															
6B	SBB B,A	OC	<<	PO	<<	Ar	Ar																
1B	SBB Rn,A	OC	<<	O1	<<	Ar	Aw																
3B	SBB Rn,B	OC	<<	O1	<<	Br	Bw																
4B	SBB Rs,Rd	OC	<<	O1	<<	Rr	O2	<<															
A3	SBIT0 Pd	OC	<<	O1	<<	O2	<<	Pr															
73	SBIT0 Rn	OC	<<	O1	<<	O2	<<	Pr															
A4	SBIT1 Pd	OC	<<	O1	<<	O2	<<	Pr															
74	SBIT1 Rn	OC	<<	O1	<<	O2	<<	Pr															
F8	SETC	OC	<<	PO	<<	Sr	Br	IC															
FE	STSP	OC	<<	PO	<<	Sr	Br	IC															
	code Instruction	1	2	3	4	5	6	7	8	9	10	11	12	13	14	15	16	17	18	19	20	21	22

Table E-2. Bus Activity Tables (Concluded)

code	Instruction	1	2	3	4	5	6	7	8	9	10	11	12	13	14	15	16	17	18	19	20	21	22
2A	SUB #n,A	OC	<<	O1	<<	Ar	Aw																
5A	SUB #n,B	OC	<<	O1	<<	Br	Bw																
7A	SUB #n,Rn	OC	<<	O1	<<	O2	<<	Rr	Rw														
6A	SUB B,A	OC	<<	PO	<<	Br	IC	Ar	Aw														
1A	SUB Rn,A	OC	<<	O1	<<	Rr	Ar	Aw															
3A	SUB Rn,B	OC	<<	O1	<<	Rr	Br	Bw															
4A	SUB Rs,Rd	OC	<<	O1	<<	Rr	Rw																
B7	SWAP A	OC	<<	PO	<<	Ar	IC	IC	IC	IC	IC	Aw											
C7	SWAP B	OC	<<	PO	<<	Br	IC	IC	IC	IC	IC	Bw											
D7	SWAP Rn	OC	<<	PO	<<	Rr	IC	IC	IC	IC	Vr	<<	SH	Vr	<<								
EF-E0	TRAP n	OC	<<	PO	<<	PO	<<	PO	<<	PO	<<												
B0	TST A	OC	<<	PO	<<	Ar	IC	IC	Ar	Aw													
C6	TST B	OC	<<	PO	<<	Br	IC	IC	Br	Bw	Bw												
B6	XCHB A	OC	<<	PO	<<	PO	<<	PO	<<	PO	<<												
D6	XCHB B	OC	<<	PO	<<	PO	<<	PO	<<	PO	<<												
D6	XCHB Rn	OC	<<	PO	<<	PO	<<	PO	<<	PO	<<												
25	XOR #n,A	OC	<<	O1	<<	Ar	Aw																
55	XOR #n,B	OC	<<	O1	<<	Br	Bw																
A5	XOR #n,Pd	OC	<<	O1	<<	O2	<<	Pr	<<	Pw	<<												
75	XOR #n,Rn	OC	<<	O1	<<	Ar	IC	Rr	<<	Rw	<<												
85	XOR A,Pn	OC	<<	O1	<<	Ar	IC	Ar	Pw	<<													
65	XOR B,A	OC	<<	PO	<<	Br	IC	Ar	Aw	<<													
95	XOR B,Pn	OC	<<	PO	<<	Br	IC	Pr	<<	Pw	<<												
15	XOR Rn,A	OC	<<	O1	<<	Ar	IC	Ar	Aw	<<													
35	XOR Rn,B	OC	<<	O1	<<	Br	IC	Ar	Aw	<<													
45	XOR Rs,Rd	OC	<<	O1	<<	Rr	IC	Bw	Rr	Rw													
code	Instruction	1	2	3	4	5	6	7	8	9	10	11	12	13	14	15	16	17	18	19	20	21	22

**General Notes:**

- 1) Opcodes and operands are executed in the same order as the written instruction. (except MOV Rs,Pd and MOV Ps,Rd)
- 2) All register pairs are accessed least significant byte then most significant byte. (n then ,n-1)
- 3) Calls push PCm then PCl,
- 4) All external writes happen on the last cycle of the instruction.
- 5) All instruction make at least one operand fetch, even if not needed. The PC counter does not advance and treats the pseudo operand as an opcode on the next opcode fetch. Identified by PO.
- 6) MPY performs Register A,B accesses and internal cycles for the number of cycles shown
- 7) DIV execution time depends on the values divided but range from 55-63 cycles. Fourteen cycles if Overflow is detected. Overflow if divisor <= Dividend msb



**Long**

Lr – Long read  
Lw – Long write  
OP – Opcode read  
On – Operand n read  
PO – Pseudo operand  
Pr – Peripheral read  
Pw – Peripheral write  
Vr – Vector read  
<< – Continuation

**Register**

Ar – Register A read  
Aw – Register A write  
Br – Register B read  
Bw – Register B write  
Rr – Register read  
Rw – Register write

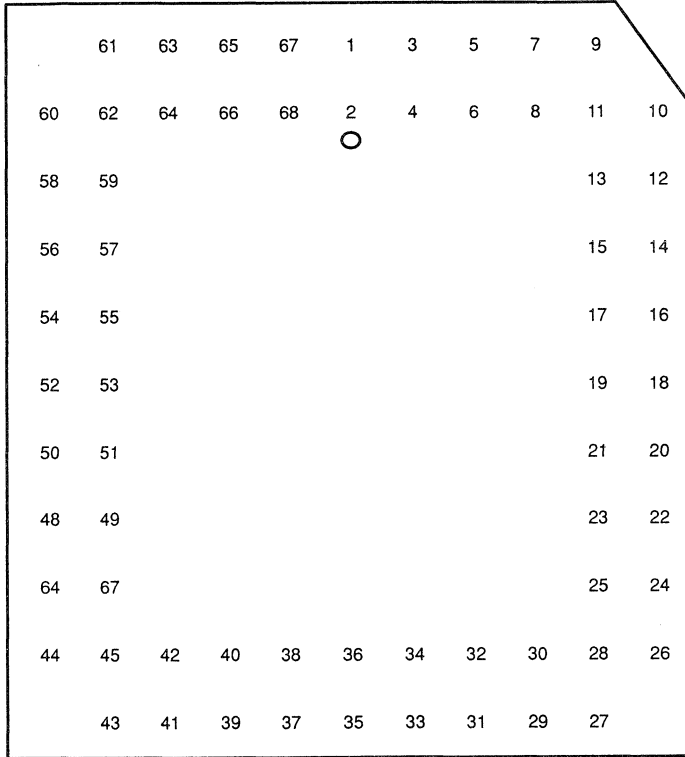
**Other**

IC – Internal cycle  
RJ – Relative jump  
SH – Stack push,  
SP – Stack pop  
Sr – Stack read





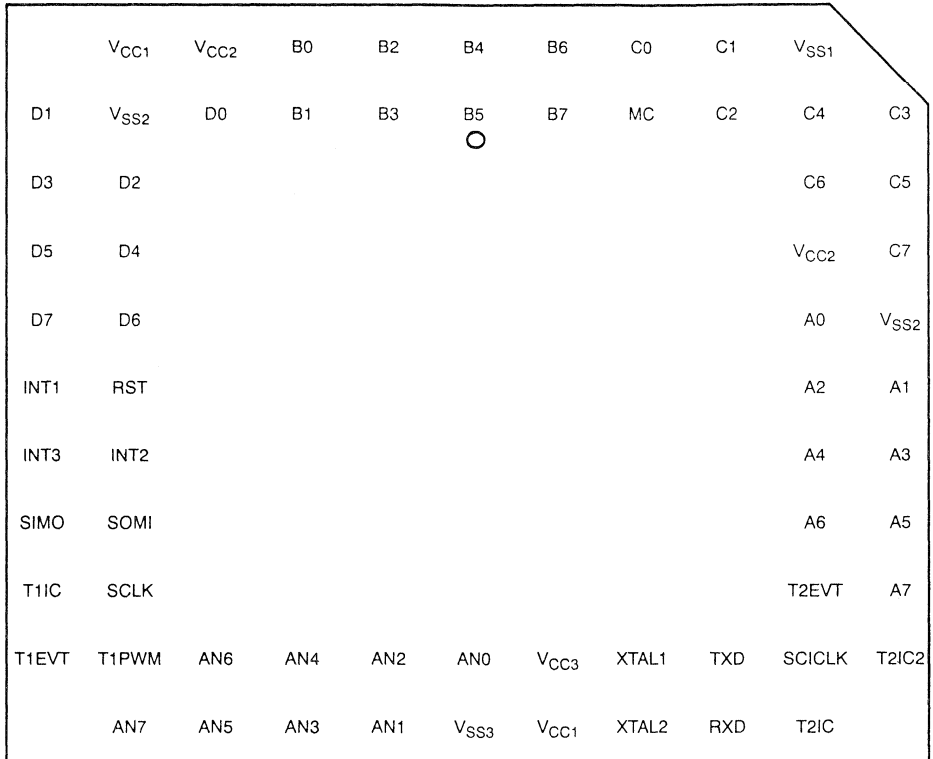
Figure F-1. 68-Pin PGA Pinout (Bottom View)



BOTTOM VIEW



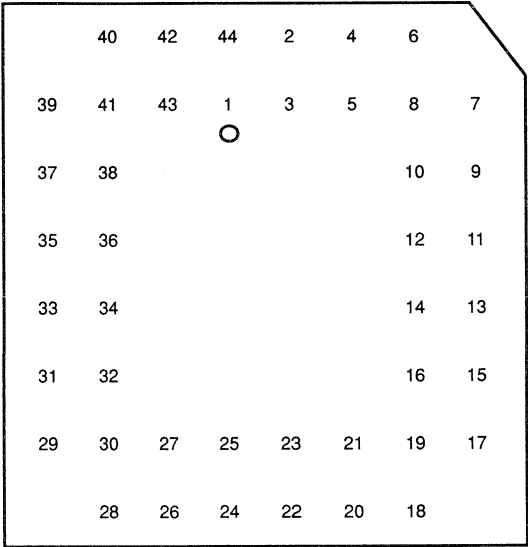
Figure F-2. TMS370Cx5x Device PGA Pinout (Bottom View)



BOTTOM VIEW



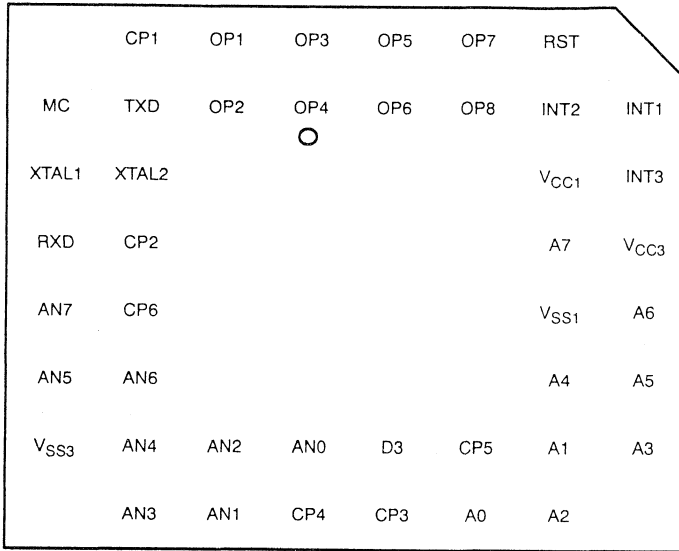
Figure F-3. 44-Pin PGA Pinout (Bottom View)



BOTTOM VIEW

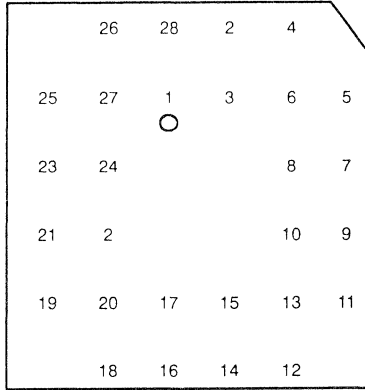


Figure F-4. TMS370Cx3x Device PGA Pinout (Bottom View)



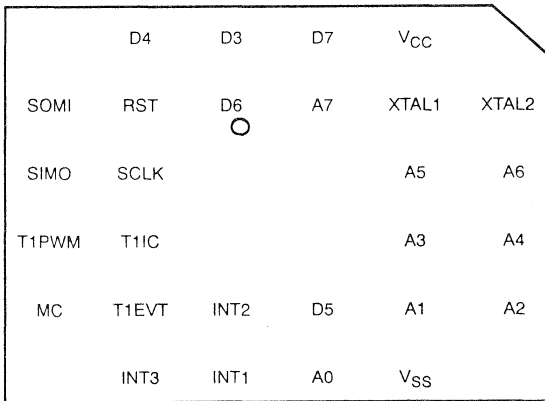
BOTTOM VIEW

Figure F-5. 28-Pin PGA Pinout (Bottom View)



BOTTOM VIEW

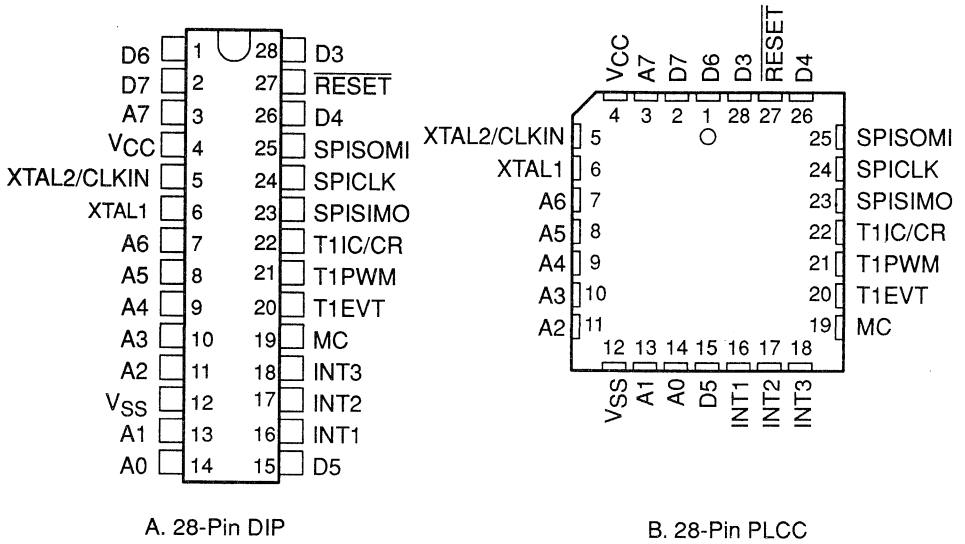
Figure F-6. TMS370Cx1x Device PGA Pinout (Bottom View)



BOTTOM VIEW



Figure F-7. Pinouts for TMS370Cx1x (Top View)



**Figure F-8. Pinout for TMS370Cx3x (Top View)**

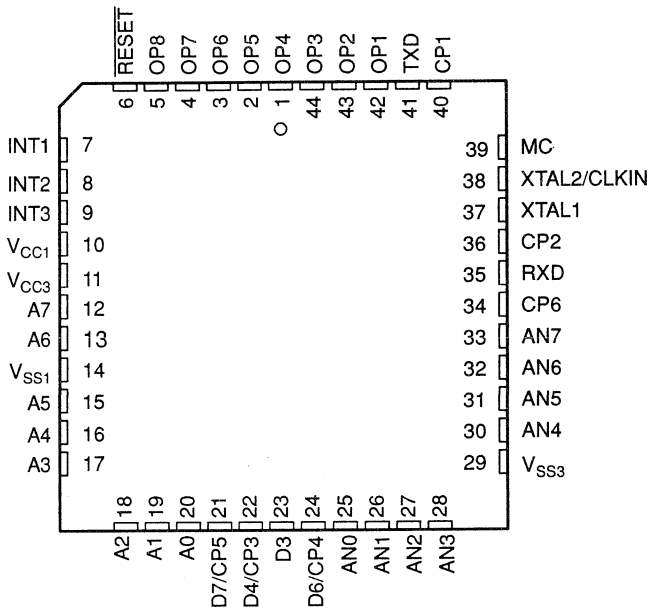
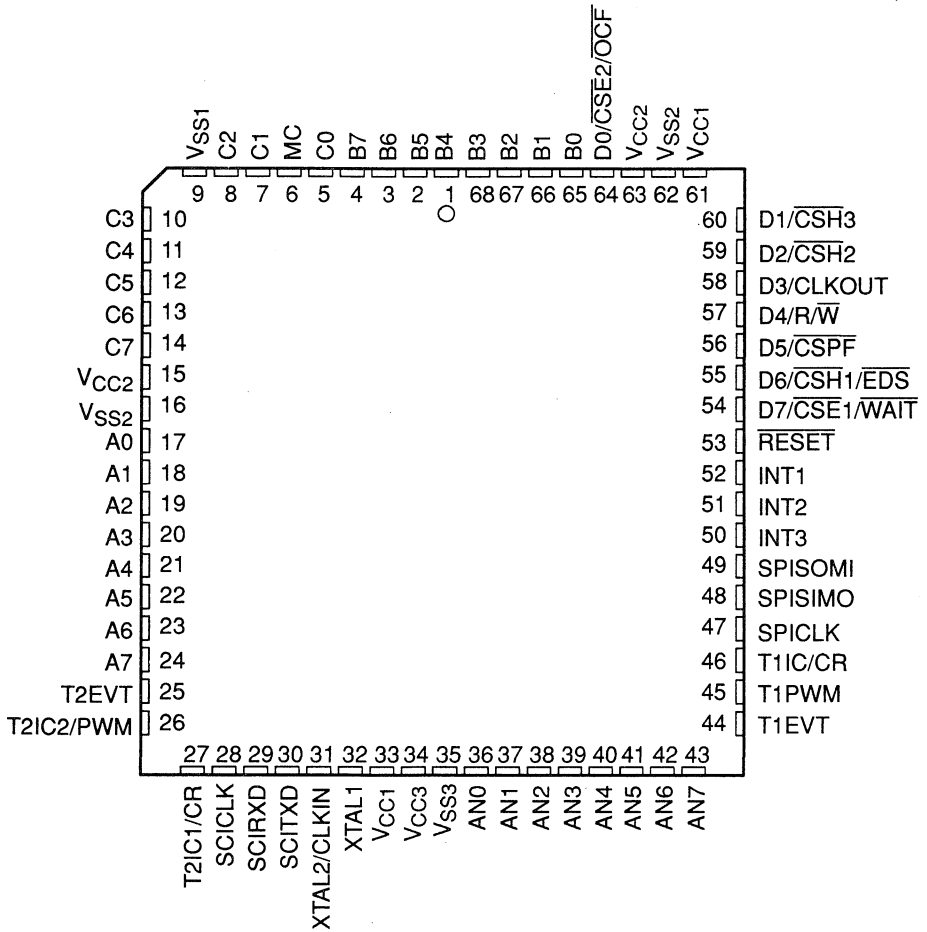
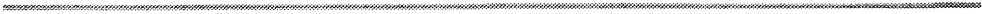




Figure F-9. Pinouts for TMS370Cx5x (Top View)





A  
H

## Appendix G

# PACT.H

---

---

---

---

---

The macros defined in the file PACT.H make it easier to define the initial values for the PACT command/definition area. The latest version of this file can be obtained from the microcontroller bulletin board. This appendix will describe some of the peculiarities of using these macros.



## G.1 General Comments

### G.1.1 Addressing Commands and Definitions in Dual-Port RAM

The initial value of the command/definition area is usually defined in program memory and then copied to dual-port RAM during the initialization routine. An example program of how to do this can be found in Section 14.5. If the values in a command or definition are to be read or written while the PACT module is running, the runtime location of that command or definition must be known. Each of the six macros allows for an optional parameter (register label) that if passed a symbol will equate it to the register containing the least significant byte of the command or definition. For example, the compare value of a standard compare command could be changed from its initial value of 80h to 100h by the movw instruction using the register label parameter.

```

stdcmp    80h,op2,enable|opp_act,pwmlen    ;if the command
                                                ;looks like this
movw     #100h,pwmlen                      ;this modifies
                                                ;the compare value
    
```

Often the code that reads or writes the command/definition area is in a separate file from the code that initializes this area. The references to specific commands or definitions can be made by declaring the register label parameter as `.globreg`. Bytes other than the least significant byte in a command or definition can be referenced as offsets from the least significant byte. Likewise individual bits can be referenced based from the definition of the least significant byte. For example the byte containing the output pin value of the standard compare command and the bit that enables that command can be referenced as shown below:

```

                .globreg pwmlen                ;PWM 1 compare value
pwmlpin        .equ pwmlen-2                  ;PWM 1 output pin byte
pwmlen        .dbit 3,pwmlen-3                ;PWM 1 enable bit
    
```

The assembler requires that global register symbols used in equates be declared `.globreg` before they are used. This can best be done by creating a file that has all of the `.globreg` symbols at the top followed by the equates and the bit definitions. This file then can be included at the beginning of the file that defines the command/definition area and again at the beginning of each file that references that area. Using this technique only the module which defines the command/definition area must be reassembled if this area changes. Modules that reference specific commands or definitions will be corrected at link time.

For the macro to be able to calculate the final destination of the command or definition two symbols must be defined before the macro is invoked. The symbols "cmd\_st" and "table" must be defined as shown in the example in Section 14.5.1.

### **G.1.2 Defining Output Pins**

The symbols op1 through op8 are defined in the PACT.H file to make it easier to read the output pin selected for a specific command. The numbers one through eight or any previously defined symbol that equates to a value in this range could be used. The macros automatically subtract one and then shift the bits into their proper place for the requested command.

### **G.1.3 Defining Actions**

Twenty three possible actions are equated to numeric values at the beginning of the PACT.H file. The commands and definitions for which each action is valid are shown in the comment section beside the equate statement. Multiple actions are concatenated by using the | operator. The numeric value assigned each action is valid only when used in the macro expansion. These symbols should not be used to set or clear the action bits while the PACT module is running.

## G.2 Comments for Specific Macros

### G.2.1 Standard Compare Command

It is not necessary to specify the compare value or the output pin if the enable action is not specified. This is commonly done when the standard compare command is used as a dummy command so that a definition may follow as shown below.

```
stdcmp ,,nxt_def ;dummy command, next line is a definition
```

### G.2.2 Conditional Compare Command

The time compare value passed to this macro will be reduced by two before it is encoded into the command. This allows the value passed to the macro to more accurately reflect the time delay until the specified actions occur. The time compare value must be greater than or equal to two.

### G.2.3 Virtual Timer Definition

The virtual timer period value passed to the macro will be reduced by two so that the desired period is achieved. This value must be able to be represented in the maximum value format described in Section 12.5.2.1. If you want to have the macro truncate the value to fit into the maximum value format without generating an error, comment out the appropriate error lines in the PACT.H file.

The initial timer value is optional, but if used it must be an even number.

### G.2.4 Baud Rate Timer Definition

The maximum count value for this definition is derived by the equation given in Section 12.8. The value obtained must then meet the maximum value format or an error will be generated.

The initial timer value is optional, but if used it must be an even number.





## PACT.H Macros

---

```
** ERROR, pin selection is illegal **
    .endif
    .if      (actions.v&0FD90h)!=0
** ERROR, illegal action specified **
    .endif
    .asg    cmpval.v&0FFh,b1.v
    .asg    (cmpval.v>>8)&0FFh,b2.v
    .if      (pin.v<1)|(pin.v>8)
    .asg    1,pin.v
    .endif
    .asg    pin.v-1,pin.v
    .asg    actions.v&63h|pin.v<<2,b3.v
    .asg    actions.v&0Ch|actions.v>>8&2h,b4.v
    .byte   b1.v,b2.v,b3.v,b4.v
    .if      lab.l!=0
    .asg    cmd_st-$(table+4),b1.v
:lab:
    .equ    r:b1.v:
    .endif
    .ENDM

;CONDITIONAL COMPARE COMMAND
; CONCMP <event compare value>,<time compare value>,<pin>,<actions>,
;       <register label>
;
; event compare value: 8-bit value compared to the event counter
; time compare value: 16-bit value compared to the reffered timer
; pin: Output pin (only pin 1-7 are valid)
; Possible actions: nxt_def,int_cmp,set_pin,clr_pin,evt_plus1
; register label: a symBol to be equated to the register containing the
;                 least significant byte of this command

CONCMP    .MACRO  evcmpval,cmpval,pin,actions,lab
    .var   b1,b2,b3,b4
    .if      (cmpval.v=0)|(cmpval.v=1)
** ERROR, compare value must be greater than 1 **
    .endif
    .asg    cmpval.v-2,cmpval.v
    .if      (pin.v>7)|(pin.v<0)
** ERROR, pin selection is illegal **
    .endif
    .if      (actions.v&07FDCh)!=0
** ERROR, illegal action specified **
    .endif
    .if      (evcmpval.v>255)|(evcmpval.v<0)
** ERROR, Event counter compare value out of range **
    .endif
    .asg    cmpval.v&0FFh,b1.v
    .asg    (cmpval.v>>8)&0FFh,b2.v
    .if      pin.v=0
    .asg    7,pin.v
    .else
    .asg    pin.v-1,pin.v
    .endif
    .asg    80h|actions.v&23h|pin.v<<2|actions.v>>9&40h,b3.v
    .asg    evcmpval.v,b4.v
    .byte   b1.v,b2.v,b3.v,b4.v
    .if      lab.l!=0
    .asg    cmd_st-$(table+4),b1.v
:lab:
    .equ    r:b1.v:
    .endif
    .ENDM
```



```

;DOUBLE EVENT COMMAND
; DEVCMP <event value 1>,<event value 2>,<output pin>,<actions>,
;     <register label>
;
; event value 1: 8-bit value compared to the event counter
; event value 2: 8-bit value compared to the event counter
; pin: Output pin
; Possible actions: nxt_def,int_evt1,set_pin,clr_pin,step,opp_act,int_evt2
;     rst_def_ev2,cap_def_ev1,cap_def_ev2,enable,
; register label: a symbol to be equated to the register containing the
;     least significant byte of this command

```

```

DEVCMP      .MACRO  e1cmpval,e2cmpval,pin,actions,lab
             .var   b1,b2,b3,b4
             .if    (e1cmpval.v>255)|(e1cmpval.v<0)
** ERROR, Event compare 1 value out of range **
             .endif
             .if    (e2cmpval.v>255)|(e2cmpval.v<0)
** ERROR, Event compare 2 value out of range **
             .endif
             .asg   e1cmpval.v,b1.v
             .asg   e2cmpval.v,b2.v
             .if    (pin.v<1)|(pin.v>8)
** ERROR, pin selection is illegal **
             .endif
             .asg   pin.v-1,pin.v
             .if    (actions.v&09984h)!=0
** ERROR, illegal action specified **
             .endif
             .asg   actions.v&063h|pin.v<<2,b3.v
             .asg   actions.v&18h|actions.v>>8&66h|1,b4.v
             .byte  b1.v,b2.v,b3.v,b4.v
             .if    lab.1!=0
             .asg   cmd st-$(table+4),b1.v
:lab:       .equ    r:b1.v:
             .endif
             .ENDM

```

```

;VIRTUAL TIMER DEFINITION
; virtmr <period>,<actions>,<initial timer value>,<register label>
;
; period: The period of the virtual timer, the maximum count plus 1
; Possible actions: enable,int_trst
; initial timer value: 16-bit virtual timer initial value.
; register label: a symbol to be equated to the register containing the
;     least significant byte of this definition

```

```

VIRTMR      .MACRO  period,actions,tmrval,lab
             .var   b1,b2,b3,b4
             .if    (period.v=0)|(period.v=1)
** Error, Max Timer value must be greater than 2 **
             .endif
             .if    (actions.v&0FFF3h)!=0
** ERROR, illegal action specified **
             .endif
             .asg   period.v-2,period.v
             .asg   tmrval.v&0FEh,b1.v
             .asg   (tmrval.v>>8)&0FFh,b2.v
             .if    ((period.v>>8)&0FFh) > 1Fh
             .asg   (period.v>>9)&70h|(period.v<<3)&80h|08h,b3.v

```

```

        .if      (period.v&0Fh)!=0
** ERROR, Max. Timer value truncated in last 4 bits **
        .endif
        .else
        .asg    (period.v<<3)&0F0h|(actions.v&0Ch)>>1,b3.v
        .if      period.v&01h!=0
** ERROR, Max. Timer value truncated in last bit **
        .endif
        .endif
        .if      tmrval.v&01h!=0
** ERROR, Timer value truncated in last bit **
        .endif
        .asg    b3.v|actions.v&0Ch>>1,b3.v
        .asg    (period.v>>5)&0FFh,b4.v
        .byte   b1.v,b2.v,b3.v,b4.v
        .if      lab.l!=0
        .asg    cmd_st-$(table+4),b1.v
:lab:
        .equ    r:b1.v:
        .endif
        .ENDM

;BAUD RATE TIMER DEFINITION
; BRTMR <maximum count>,<actions>,<initial timer value>,<register label>
;
; maximum count: number that determines the baud rate
; initial timer value: 16-bit virtual timer initial value
; Possible actions: rx,tx
; register label: a symbol to be equated to the register containing the
;                  least significant byte of this definition

```

```

BRTMR      .MACRO  maxcount,actions,tmrval,lab
          .var    b1,b2,b3,b4
          .if      ((actions.v&0E7FFh)!=0)
** ERROR, illegal action specified **
          .endif
          .asg    tmrval.v&0FEh,b1.v
          .asg    (tmrval.v>>8)&0FFh,b2.v
          .if      ((maxcount.v>>8)&0FFh) > 1Fh
          .asg    (maxcount.v>>9)&70h|(maxcount.v<<3)&80h|08h,b3.v
          .if      maxcount.v&0Fh!=0
** ERROR, Max. Timer value truncated in last 4 bits **
          .endif
          .else
          .asg    (maxcount.v<<3)&0F0h,b3.v
          .if      maxcount.v&01h!=0
** ERROR, Max. Timer value truncated in last bit **
          .endif
          .endif
          .if      tmrval.v&01h!=0
** ERROR, Timer value truncated in last bit **
          .endif
          .asg    (maxcount.v>>5)&0FFh,b4.v
          .asg    b3.v|((actions.v&1800h)>>10)|1,b3.v
          .byte   b1.v,b2.v,b3.v,b4.v
          .if      lab.l!=0
          .asg    cmd_st-$(table+4),b1.v
:lab:
          .equ    r:b1.v:
          .endif
          .ENDM

```

;OFFSET TIMER DEFINITION

```

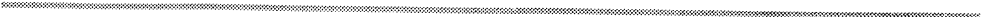
; OFSTMR <max event count>,<actions>,<initial value>,<register label>
;
; max event count: The maximum value the event counter may reach before
;                 being reset.
; Possible actions: step,int_max_evt,enable,rst_def_tmr,
;                 vir_cap,def_cap,int_evt
; initial value: 16-bit initial timer value
; register label: a symbol to be equated to the register containing the
;                 least significant byte of this definition

```

```

OFSTMR      .MACRO maxcount,actions,tmrval,lab
            .var    b1,b2,b3,b4
            .if    (maxcount.v>255)|(maxcount.v<0)
** ERROR, Maximum event value out of range **
            .endif
            .if    ((actions.v&09E27h)!=0)
** ERROR, illegal action specified **
            .endif
            .asg   (tmrval.v&0FFh|1),b1.v
            .asg   (tmrval.v>>8)&0FFh,b2.v
            .asg   (actions.v&090h)|((actions.v&8)>>1)|(actions.v&40h)>>6,b3.v
            .asg   b3.v|((actions.v&100h)>>7)|((actions.v>>8)&60h),b3.v
            .asg   maxcount.v&0FFh,b4.v
            .byte  b1.v,b2.v,b3.v,b4.v
            .if    lab.l!=0
            .asg   cmd_st-$(table+4),b1.v
:lab:      .equ    r:b1.v:
            .endif
            .ENDM

```



A  
H

# Glossary

---

---

This appendix provides definitions of terms and concepts unique to the TMS370 family of devices. Other common terms are included if the use of those terms varies from generally accepted usage.

### A

**absolute address:** An addressing mode in which code or operands produce the actual address.

**A/D pins:** The 10 pins that connect the A/D module to the external world; includes AN0–7,  $V_{SS3}$ , and  $V_{CC3}$ .

**addressing mode:** The method by which an instruction calculates the location of its required data.

**AN0—AN7 pins:** Eight analog input channels to the A/D converter or digital inputs; seven of which can be configured as the voltage reference channel.

**analog-to-digital (A/D) converter:** The TMS370 A/D Converter is an 8-bit successive-approximation converter with internal sample-and-hold circuitry.

**assembly language:** A symbolic language that describes the binary machine code in a more readable form. Each of the 73 unique instructions of the TMS370 family converts to one machine operation.

**asynchronous communications mode:** An serial communications format that needs no synchronizing clock. This format consists of a start bit followed by data bits, an optional parity bit and ends with a stop bit. This format is commonly used with RS-232-C communications and PC serial ports.

### B

**BCD:** Binary coded decimal; each 4 bit nibble expresses a digit from 0–9, and usually packs two digits to a byte giving a range of 0–99.

**Baud Rate Timer Definition:** An entry in the PACT command/definition area that creates a virtual timer which establishes the baud rate for the PACT mini SCI.

**baud rates:** The communication speed for serial ports; equivalent to bits per second.

**buffer pointer:** A 5-bit register in the PACT module peripheral frame that points to the next available location in the circular capture buffer.

**C**

**Capture register:** A Timer 1 or Timer 2 register which is loaded with the 16-bit counter value on the occurrence of an external input transition. Either edge of the external input can be configured to trigger the capture.

**chip select:** For some blocks of the TMS370 memory map, the most significant bits of the address are pre-decoded to activate chip-select signals. These chip-select signals allow the TMS370 to access external addresses with a minimum of external logic and to perform memory bank selection under software control.

**circular buffer:** A variable length area in the PACT module dual-port RAM that is used for storing the value of a PACT timer when a capture request is made. As new values are captured they will be put into successive locations in the buffer. When the buffer is full the oldest captures will be replaced with newer captures.

**command/definition area:** A variable length area in the PACT module dual-port RAM that is used to define the actions taken by the PACT module.

**Compare register:** The compare register, in the Timer 1 or Timer 2 module, contains a value which is compared to the counter value. The compare function triggers when the counter matches the contents of the compare register.

**Conditional Compare Command:** An entry in the PACT command/definition area that is used to create actions such as interrupts or transitions on an output pin based on the event counter value and a timer value.

**constant:** A value which does not change during execution.

**CPU:** The TMS370 CPU is an 8-bit register oriented processor with Status register, Program Counter register, and Stack Pointer. The CPU uses the Register File, accessed in one bus cycle, as working registers.

**A  
H**

## D

**dedicated capture registers:** An area in the PACT module dual-port RAM that is used to store the value of the default timer at the time of a specified edge on one of the PACT input capture pins. Unlike the circular buffer, the location of the dedicated capture register does not change.

**default timer:** A 20-bit hardware counter in the PACT module that is incremented by the PACT prescaled clock. It is sometimes referred to as the hardware timer.

**Double Event Compare Command:** An entry in the PACT command/definition area that is used to create actions such as interrupts or transitions on an output pin based on the event counter equaling one of two values.

**dual-ported RAM:** An area in random access memory that can be read and written by both the TMS370 CPU and the PACT module.

## E

**edge detection:** Edge detection circuitry senses an active pulse transition on a given timer input and provides appropriate output transitions to the rest of the module. The active transition can be configured to be low-to-high or high-to-low.

**EEPROM:** Electrically Erasable Programmable Read Only Memory has the capability to be programmed and erased under direct program control.

**event counter:** An 8-bit hardware register in the PACT module that is incremented by the selected edges on input capture pin 6.

**Extended Addressing mode:** An addressing mode with an 16-bit range.

## G

**General Addressing mode:** An addressing mode with an 8-bit range.

## H

**Halt mode:** The Halt mode reduces operating power by stopping the internal clock which stops processing in all the modules. This is the lowest-power mode in which all Register contents are preserved.

**hardware timer:** A 20-bit hardware counter in the PACT module that is incremented by the PACT prescaled clock. It is sometimes referred to as the default timer.

## I

**IDLE instruction:** The IDLE instruction causes the device to enter one of three modes; Idle, Halt, or Standby.

**idle mode:** In the Idle mode, the CPU stops processing and waits for the next interrupt. This is not a low power mode.

**immediate operand:** An operand whose actual constant value is specified in the instruction and placed after the opcode in the machine code.

**index:** An 8-bit unsigned number added to a base address to give a final address.

**instruction:** The basic unit of programming which causes the execution of one operation; consists of an opcode and operands along with optional labels and comments.

**interrupts:** A signal input to the CPU to stop the flow of a program and force the CPU to execute instructions at an address corresponding to the source of the interrupt. When the interrupt is finished, the CPU resumes execution at the point where it was interrupted.

**INT1 pin:** A pin connected to external devices to allow them to interrupt the CPU; INT1 can be software configured as a non-maskable interrupt.

**INT2 and INT3 pins:** Pins connected to external devices to allow them to interrupt the CPU.

**Isosynchronous Communications mode:** An SCI mode in which data transmission is synchronized by a clock signal (SCICLK) common to both the sender and receiver. The format is identical to the asynchronous mode and consists of a start bit, data bits, an optional parity bit and a stop bit.

**machine code:** The actual bytes read by the CPU during an instruction execution; usually read by a programmer as hexadecimal bytes.

**MC pin:** Mode Control pin, the voltage on this pin during reset determines the operating mode of the TMS370 device; 12 volts on the MC pin after reset places the processor in the Write Protection Override mode (WPO).

**memory map:** A description of the addresses of the various sections and features of the TMS370 processor. The map depends on the operating mode.



**Microcomputer mode w/external expansion:** An operating mode in which the address, control and data buses extend off-chip to access external memory or peripherals.

**Microcomputer single-chip mode:** An operating mode in which the device uses only on-chip memory.

**Microprocessor mode w/ internal program memory:** An operating mode in which the on-chip program memory is available to the processor.

**Microprocessor mode w/o internal program memory:** An operating mode in which the on-chip program memory is not available to the processor. The processor must have external memory.

**$\mu$ P/ $\mu$ C Mode bit:** Microprocessor/Microcomputer Mode bit; shows whether the device initializes into the microcomputer modes or the microprocessor operating mode.

**mnemonic:** A symbol chosen to aid human memory; commonly used to refer to the symbol representing the opcode part of an assembly language instruction.

**multiprocessor communications:** A SCI format option which enables one processor to efficiently send blocks of data to other processors on the same serial link.

**N**

**nested interrupts:** The ability of an interrupt to suspend the service routine of a prior interrupt; implemented in TMS370 devices by executing an interrupt service routine which uses the EINT, EINTL or EINTH instructions to set the global Interrupt Enable bits in the status register.

**non-maskable interrupt (NMI):** Activation of a NMI always causes the processor to execute the NMI routine. On TMS370 devices, INT1 can be configured as an NMI.

**A-H****O**

**offset:** A signed value that is added to the base operand to give the final address.

**Offset Timer Definition-Time from Last Event:** An entry in the PACT command/definition area that is used to create an independent time base which is incremented by the PACT prescaled clock and cleared each time the event counter is incremented.

**opcode:** Operation code. The first byte of the machine code which describes to the CPU the type of operation and combination of operands. Some TMS370 instructions use 16-bit opcodes.

**operand:** The part of an instruction which tells the programmer where the CPU will fetch or store data.

**output compare:** See Compare register.

**P**

**PACT:** The Programmable Acquisition and Control Timer module, a timer co-processor module for the TMS370 microcontroller family.

**Peripheral File (PF):** The 256 bytes of memory, starting at 1000h, containing the registers which control the on-board peripherals and system configuration. peripheral file frame A set of 16 contiguous peripheral file registers, usually related by function. One of two power reduction modes. See Halt mode and Standby mode.

**PPM:** Pulse Position Modulation. A serial signal in which the information is contained in the frequency of a signal with a constant pulse width. A TMS370 device can output a PPM signal with a constant duty cycle without any program intervention using the Timer compare features.

**prescaled clock:** The clock signal that comes from the PACT module prescaler circuitry. This signal determines the resolution of the PACT module.

**prescaler:** A circuit which slows the rate of a clocking source to the counter. The Timer 1 prescaler can slow the clocking source by a factor of 4, 16, 64, or 256.

**privilege mode:** A mode immediately following reset in which the program can alter the privileged registers. Once the privileged mode is disabled, these registers cannot be changed until another reset. This mode does not affect the EEPROM or the Watchdog registers.

**prototyping device:** A device used before masked ROM devices are available which have identical functions, pinout, size and timings. Programmable memory such as EEPROM or EPROM is used in place of the masked ROM.

**pulse accumulation:** A Timer 1 mode which keeps a cumulative count of SYSCLK pulses gated by the T1EVT signal.

**PWM:** Pulse Width Modulation. A serial signal in which the information is contained in the width of a pulse of a constant frequency signal. A TMS370 device can output a PWM signal with a constant duty cycle without any program intervention using the Timer compare features.

## R

**ratiometric conversion:** An Analog-to-Digital conversion in which the conversion value is a ratio of the  $V_{REF}$  source to the analog input. As  $V_{REF}$  is increased, the input voltage needed to give a certain conversion value changes; but all conversion values keep the same relationship to  $V_{REF}$ .

**referred timer:** The timer that a PACT command uses for time comparisons. This is the last timer defined in the PACT command/definition area before the command was encountered, or if no timer has been defined, it is the least significant 16-bits of the hardware timer.

**Register File (RF):** The first 256 bytes of memory which can be accessed by the majority of the instructions.

**relative:** Operands and code which produce an absolute address at some distance from the current location.

**RESET pin:** A low level on this pin starts hardware initialization and insures an orderly software startup. If the MC pin is low when the  $\overline{RESET}$  signal returns high, then the processor enters the microcomputer mode. If the MC pin is high when the  $\overline{RESET}$  signal returns high, then it enters the microprocessor mode. Serial Communications Interface (SCI) The SCI module is a built-in serial interface which can be programmed to be asynchronous or isosynchronous. Many timing, data format, and protocol factors are programmable and controlled by the SCI module in operation.

## S

**PACT-SCI:** The mini UART function available in the PACT module.

**SCICLK pin:** Serial Communications Interface Clock pin. Used as a synchronizing clock input or output in the Isoynchronous mode, or as a general purpose I/O pin.

**Serial Peripheral Interface (SPI):** The SPI module is a built-in serial interface which facilitates communication between networked master and slave CPUs. As in the SCI, the SPI is setup by software and from then on, the CPU takes no part in timing, data format, or protocol.

**signed integer:** a number system used to express positive and negative integers.

**SPICLK pin:** Serial Peripheral Interface Clock. If the SPI is in the Master mode, this pin provides the serial clock for the entire serial communica-

tions network. If the SPI is in the Slave mode, this pin is the serial clock input.

**SPISIMO pin:** Serial Peripheral Interface Slave In, Master Out. In the master mode, data is output on the SPISIMO pin on the first SPICLK edge and latched from the SPISOMI pin on the opposite edge of SPICLK. In the slave mode, data is output on the SPISOMI pin on the first SPICLK edge and latched from the SPISIMO pin on the opposite edge of SPICLK.

**SPISOMI pin:** Serial Peripheral Interface Slave Out, Master In. See SPISIMO.

**Stack:** That part of the Register File used as last-in, first-out memory for temporary variable storage. Used during interrupts and calls, to store the current program status. The area occupied by the stack is determined by the Stack Pointer and the application program.

**Stack Pointer (SP):** An 8-bit CPU register that points to the last entry or top of the stack. The SP is automatically incremented before data is pushed onto the stack and decremented after data is popped from the stack.

**standard compare command:** An entry in the PACT command/definition area that is used to create actions such as interrupts or transitions on an output pin based on a timer value equaling the value defined in this command.

**Standby mode:** A power reduction mode in which the CPU stops processing, but the on-chip oscillator remains active. Timers remain active and can cause the CPU to exit the standby mode.

**Status register (ST):** A CPU register which monitors the operation of the instructions and contains the global interrupt enable bits.

**time slot:** A name for the internal cycles in which the PACT module can make a 32-bit access to the dual-port RAM. Each command or definition requires one, two or three time slots. The number of time slots available is a function of the PACT prescaled clock and the frequency of access to the dual port RAM by the CPU.

**TRAP:** Trap-to-subroutine. An assembly language instruction which is a one-byte subroutine call. An operand <n> is a trap number that identifies a location in the trap vector table, addresses 07FC0h to 07FDFh in memory, containing the address of the subroutine.



**T2IC1/CR pin:** Timer 2 Input Capture 1/Counter Reset pin. A Timer 2 module pin which is an input to the counter reset, input capture, or PWM circuit.

**T2IC2/PWM pin:** Timer 2 Input Capture 2/Pulse Width Modulation pin. A Timer 2 module pin which is the Pulse Width Modulation output or a second input capture.

**U**

**unsigned integer:** a number system used to express positive integers.

**V**

**virtual timers:** An entry in the PACT command/definition area that is used to create an independent time base which is incremented by the PACT prescaled clock and cleared upon reaching a maximum value that is set by this definition.

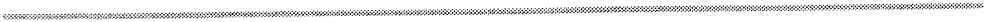
**W**

**WAIT pin :** Allows an external device to cause the processor to wait an indefinite number of clock cycles. When the wait line is released, the processor resynchronizes with the rising edge of the clockout signal and continues with the program.

**wait states, automatic:** Extra clock cycles inserted automatically on every external memory access to accommodate peripherals or expansion memory with slower access time than the TMS370 processor. These Wait states are governed by two control bits: PF AUTO WAIT and AUTO-WAIT DISABLE.

**watchdog timer:** A timer option which can be programmed to generate an interrupt when it times out. This function provides a hardware monitor over the software to prevent a "lost" program. This function is available in both the Timer 1 and PACT modules. If Timer 1 does not need a watchdog, this timer can be used as a general purpose timer.

**Write Protect Override (WPO):** The only mode in which a TMS370 device can modify the on-board EEPROM. The WPO mode is entered when external circuitry applies 12 volts to the MC pin after the device has been Reset into one of its normal operating modes.



# Index

## Nu

16-bit register access, 7-24, 8-16

## A

A/D, 1-10

ADC, Add with Carry Instruction, 13-19,  
13-31

ADD, Add Instruction, 13-19, 13-32

addition instructions, 13-31, 13-32, 13-46,  
13-56, 13-57

Additional Addressing Modes, 13-17

Addressing Modes

Additional, 13-17

Direct, 13-11

Extended Addressing Modes, 13-10

General Addressing Modes, 13-4

Immediate, 13-7

indexed, 13-12

indirect, 13-14

offset indirect, 13-15

Peripheral File, 13-6

Program Counter Relative, 13-8, 13-9

Single Register, 13-5

Stack Pointer Relative, 13-9

Analog-to-Digital (A/D) Converter

A/D Converter Ready (AD READY), 11-13

A/D Interrupt Enable bit (AD INT ENA),  
11-13

A/D Interrupt Flag (AD INT FLAG), 11-13

A/D Interrupt Priority Select (AD PRIOR-  
ITY), 11-17

AD INT ENA bit, 11-6

AD INT FLAG, 11-6

AD PRIORITY bit, 11-6

analog control register (ADCTL), 11-11

analog conversion data register  
(ADDATA), 11-14

Analog Input Channel Select Bits

(AD INPUT SELECT0–2), 11-11

analog interrupt priority register

(ADPRI), 11-17

analog port E data input register

(ADIN), 11-15

analog port E input enable register

(ADENA), 11-16

analog status and interrupt register

(ADSTAT), 11-13

block diagram, 11-3

control registers, 11-4

conversion process, 11-5

CONVERT START bit, 11-7

Convert Start bit (CONVERT START),  
11-12

DATA7–DATA0 bits, 11-14

Emulator Suspend Enable (AD ESPEN),  
11-17

example program, 11-8

I/O pins, 11-5

interrupts, 11-6

memory map, 11-4

operation, 11-5

overview, 11-2

physical description, 11-2

PORT E DATA AN 7 –PORT E DATA

AN 0 bits, 11-15

- PORT E INPUT ENA 7–PORT E INPUT
    - ENA 0, 11-16
    - programming considerations, 11-7
    - ratiometric conversion, 11-6
    - Reference Voltage bits (REF VOLT SELECT0–2), 11-11
    - SAMPLE START bit, 11-7
    - Sample Start bit (SAMPLE START), 11-12
    - sampling time, 11-5
  - analog-to-digital converter, 1-10
  - AND, Logical AND Instruction, 13-19, 13-33
  - applicable documents, 1-13
  - applications, 1-4
  - architecture overview, 1-5
  - Array Program (AP) bit, 6-4, 6-10, 6-11
  - ASCII Table, C-2
  - assembly language, 13-1
  - Assembly Language Instructions
    - ADC, 13-19
    - ADD, 13-19
    - AND, 13-19
    - BR, 13-19
    - BTJO, 13-19
    - BTJZ, 13-20
    - CALL, 13-20
    - CALLR, 13-20
    - CLR, 13-20
    - CLRC, 13-20
    - CMP, 13-20
    - CMPBIT, 13-20
    - CMPL, 13-20
    - DAC, 13-21
    - DEC, 13-21
    - DINT, 13-21, 13-48
    - DIV, 13-21, 13-49
    - DJNZ, 13-21, 13-50
    - DSB, 13-21, 13-51
    - EINT, 13-21, 13-52
    - EINTH, 13-21, 13-53
    - EINTL, 13-21, 13-54
    - IDLE, 4-7, 13-22
    - INC, 13-22, 13-56
    - INCW, 13-22, 13-57
    - INV, 13-22
    - J<cond>, 13-63
    - JBIT0, 13-22, 13-59
    - JBIT1, 13-22, 13-60
    - JMP, 13-22
    - JMPL, 13-22, 13-62
    - jump instructions, 13-50
    - LDSP, 13-23, 13-65
    - LDST, 3-6, 13-23, 13-66
    - MOV, 13-24, 13-67
    - MOVW, 13-24, 13-69
    - MPY, 13-24, 13-70
    - NOP, 13-24
    - OR, 13-25
    - POP, 13-25, 13-73
    - PUSH, 13-25, 13-74
    - RL, 13-25, 13-75
    - RLC, 13-25, 13-76
    - RR, 13-25, 13-77
    - RRC, 13-25, 13-78
    - RTI, 5-2, 13-25, 13-79
    - RTS, 13-25, 13-80
    - SBB, 13-25, 13-81
    - SBIT0, 13-26, 13-82
    - SBIT1, 13-26, 13-83
    - SETC, 13-26, 13-84
    - STSP, 13-26, 13-85
    - SUB, 13-26, 13-86
    - SWAP, 13-26
    - TRAP, 13-88
    - TRAP n, 13-26
    - TST, 13-26, 13-89
    - XCHB, 13-26, 13-90
    - XOR, 13-26
  - Assembly Language Tools, 15-3
  - asynchronous SCI, 1-9
  - Automatic Wait State Disable (AUTOWAIT DISABLE) bit, 4-12
  - automatic wait states, 4-4
  - AUTOWAIT DISABLE bit, 4-5
- B**
- baud rate timer definition, 12-13, 12-21, 12-23
  - Block Diagrams, Appendix B
  - BR, Branch Instruction, 13-19, 13-34



BTJO, Bit Test and Jump If One Instruction, 13-19, 13-35

BTJZ, Bit Test and Jump If Zero Instruction, 13-20, 13-37

buffer pointer, 12-20, 12-44

Bus Activity Tables, E-4

BUSY bit, 6-5, 6-7, 6-10

## C

C (carry) bit, 13-84

CALL, Call Instruction, 13-20, 13-38

CALLR

Call Relative Instruction, 13-39

CALLR Instruction, 13-20

capture, 7-3

Carry (C) bit, 3-5, 13-41

character sets, C-2

Chip Select Eighth 1 (CSE) signal, 4-18

Chip Select Eighth 2 (CSE2) signal, 4-18

Chip Select Half 1 (CSH1) signal, 4-17

Chip Select Half 2 (CSH2) signal, 4-17

Chip Select Half 3 (CSH3) signal, 4-18

Chip Select Peripheral File (CSPF), 4-18

circular buffer, 12-5, 12-14

clear, 1-12

Clock Output (CLKOUT) signal, 4-18

CLR, Clear Instruction, 13-20, 13-40

CLRC, Clear the Carry Bit Instruction, 13-20, 13-41

CMOS devices

See Chapter 2 and Chapter 4

CMP, Compare Instruction, 13-20, 13-42

CMPBIT, Complement Bit Instruction, 13-20, 13-44

CMPL, Two's Complement Instruction, 13-20

COLD START bit, 4-11

command/definition area, 12-16, 12-21

compare instructions, 13-42, 13-44, 13-45

compare register, 7-16

compare register, 7-15

interrupt flags, 7-16

interrupts, 7-16

T1C2 INT FLAG, 7-16

T1EDGE INT FLAG, 7-16

T1PWM, 7-16

COMPL, Two's Complement Instruction, 13-45

condition flags (C, N, Z, V), 3-6

Conditional Compare Command, 12-13, 12-26

conditional jumps, 13-63

counter clock source, 7-26

CPU, 1-8

CPU registers, 3-3

## D

DAC, Decimal Add with Carry Instruction, 13-21, 13-46

Data EEPROM, 1-5, 1-8, 3-12, 6-2

Data EEPROM programming, 6-5

data memory, 1-5

DEC, Decrement Instruction, 13-21, 13-47

dedicated capture registers, 12-5

DEECTL register, 6-2, 6-4

default counter, 12-8

default timer, 12-14

development support, 15-1

ordering information, 17-15, 17-16

device comparison, 2-4

digital I/O configuration, 4-15

digital port control registers, 4-15

digital ports set-up example, 4-19

DINT, Disable Interrupts Instruction, 13-21, 13-48

Direct Addressing modes, 13-11

DIV

Divide Instruction, 13-49

Integer Divide Instruction, 13-21

DIV instruction, 13-49

DJNZ

Decrement Register and Jump If Not Zero Instruction, 13-50

Decrement Relative and Jump If Not Zero Instruction, 13-21

Double Event Compare Command, 12-11, 12-27  
DSB, Decimal Subtract with Borrow Instruction, 13-21, 13-51  
dual port RAM, 12-8  
dual-ported RAM, 12-6, 12-14

## E

edge detection, Timer 1, 7-13  
    compare register, 7-15  
    counter reset, 7-14  
    counter reset sources, 7-14  
    general purpose counter, 7-14  
    T1 OVRFL INT FLAG, 7-14  
    T1C1 INT FLAG, 7-15  
    T1CR OUT ENA, 7-14  
    T1CR RST ENA, 7-14  
    T1EDGE DET ENA, 7-13, 7-14  
    T1EDGE INT FLAG, 7-13  
    T1EDGE POLARITY, 7-13, 7-14  
    T1PWM, 7-14  
EEPROM, 1-8  
EEPROM modules, 6-1  
EEPROM programming, 6-6  
EEPROM, data, 3-12  
EEPROM, program, 3-14  
EINT, Enable Interrupts Instruction, 13-21, 13-52  
EINTH  
    EINT High Priority Instruction, 13-21  
    Enable High Level Interrupts Instruction, 13-53  
EINTL  
    EINTL Low Priority Instruction, 13-21  
    Enable Low Level Interrupts Instruction, 13-54  
event counter, 12-5, 12-8, 12-14  
Execute (EXE) bit, 6-4, 6-10  
Extended Addressing Modes, 13-10  
External Data Strobe (EDS) signal, 4-17  
external interrupt control registers, 5-7  
external interrupt pins (INT1, INT2, INT3), 5-7

external interrupts, 5-7

## F

family devices summary, 2-1  
Form Factor Emulators, 15-27  
frame, peripheral file, 3-11  
function A expansion signals, 3-19  
function B expansion signals, 3-20

## G

General Addressing Modes, 13-4  
global interrupt enable bits (IE1 and IE2), 5-2

## H

Halt mode, 4-6, 4-7  
HALT/STANDBY bit, 4-7, 4-14  
hardware interrupts, 5-6  
hardware timer, 12-5

## I

I/O ports, 1-8  
IDLE, Idle Until Interrupt Instruction, 13-22, 13-55  
IDLE instruction, 4-6, 4-7  
idle modes, 4-6  
Immediate Addressing mode, 13-7  
Implied, 13-4  
INC, Increment Instruction, 13-22, 13-56  
INCW, Increment Word Instruction, 13-22, 13-57  
indexed addressing modes, 13-12  
indirect addressing modes, 13-14  
Instruction/Opcode Cross Reference, E-2  
INT DATA DIR bit, 5-8  
INT DATA OUT bit, 5-8  
INT ENABLE bit, 5-8  
INT FLAG bit, 5-8  
INT PIN DATA bit, 5-8  
INT POLARITY bit, 5-8

- INT PRIORITY bit, 5-8
  - Interrupt 1 Control Register (INT1), 5-10
  - Interrupt 1 Enable (INT1 ENABLE) bit, 5-10
  - Interrupt 1 Flag (INT1 FLAG) bit, 5-10
  - Interrupt 1 Pin Data (INT1 PIN DATA) bit, 5-10
  - Interrupt 1 Polarity (INT1 POLARITY) bit, 5-10
  - Interrupt 1 priority (INT1 PRIORITY) bit, 5-10
  - Interrupt 1, Non-Maskable Interrupt (INT1 NMI) bit, 4-13
  - Interrupt 2 Control Register (INT2), 5-11
  - Interrupt 2 Data Direction (INT2 DATA DIR) bit, 5-11
  - Interrupt 2 Data Out (INT2 DATA OUT) bit, 5-11
  - Interrupt 2 Enable (INT2 ENABLE) bit, 5-11
  - Interrupt 2 Flag (Interrupt 2 Flag), 5-11
  - Interrupt 2 Pin Data (INT2 PIN DATA), 5-11
  - Interrupt 2 Polarity (INT2 POLARITY) bit, 5-11
  - Interrupt 2 Priority (INT2 PRIORITY), 5-11
  - Interrupt 3 Control Register (INT3), 5-12
  - Interrupt 3 Data Direction (INT3 DATA DIR) bit, 5-12
  - Interrupt 3 Data Out (INT3 DATA OUT) bit, 5-12
  - Interrupt 3 Enable (INT3 ENABLE) bit, 5-12
  - Interrupt 3 Flag (INT3 FLAG), 5-12
  - Interrupt 3 Pin Data (INT3 PIN DATA) bit, 5-12
  - Interrupt 3 Polarity (INT3 POLARITY) bit, 5-12
  - Interrupt 3 priority (INT3 PRIORITY) bit, 5-12
  - interrupt context switch, 5-6
  - interrupt control registers, 5-7
  - interrupt enable bits (IE1 and IE2), 5-2, 5-13
  - interrupt priority levels, 5-2
  - interrupt routines, nested, 5-13
  - interrupt vector addresses, 5-4, 5-6
  - interrupts, 5-2
    - DINT instruction, 13-48
    - EINT instruction, 13-52
    - EINTH instruction, 13-53
    - EINTL instruction, 13-54
    - RTI instruction, 13-79
  - interrupts, external, 5-7
  - interrupts, hardware, 5-6
  - INV, Invert Instruction, 13-22, 13-58
  - isochronous SCI, 1-9, 9-3, 9-4, 9-9
- 
- J
- J<cond>, Jump on Condition Instruction, 13-63
  - JBIT0
    - Conditional Jump Instruction, 13-22
    - Jump If Bit = 0 Instruction, 13-59
  - JBIT1
    - Condition Jump Instruction, 13-22
    - Jump If Bit = 1 Instruction, 13-60
  - JC, 13-23
  - JEQ, 13-23
  - JG, 13-23
  - JGE, 13-23
  - JHS, 13-23
  - JL, 13-23
  - JLE, 13-23
  - JLO, 13-23
  - JMP, Jump Unconditional Instruction, 13-22, 13-61
  - JMPL
    - Jump Long Instruction, 13-62
    - Jump Unconditional Instruction, 13-22
  - JN, 13-23
  - JNC, 13-23
  - JNE, 13-23
  - JNV, 13-23
  - JNZ, 13-23
  - JP, 13-23
  - JPZ, 13-23
  - jump instructions, 13-35, 13-37, 13-50, 13-59, 13-60, 13-61, 13-62, 13-63
  - JV, 13-23
  - JZ, 13-23

## L

LDSP, Load Stack Pointer Instruction, 13-23, 13-65  
LDST, Load Status Register Instruction, 13-23, 13-66  
LDST instruction, 3-6  
Level 1 Interrupt Enable (IE1) bit, 3-5  
level 1 interrupts, 5-2  
Level 2 Interrupt Enable (IE2) bit, 3-5  
level 2 interrupts, 5-2  
linker, 15-5

## M

MC pin, 3-15  
mechanical data, 17-6  
MEMORY DISABLE bit, 3-22, 4-12  
memory expansion, 3-17  
memory maps, 3-8, 3-24  
memory mode summary, 3-24  
memory operating modes, 3-15  
microcomputer mode, 4-21  
microcomputer mode with external expansion, 3-17  
microcomputer single-chip mode, 3-16  
microprocessor mode, 4-21  
microprocessor mode with internal program memory, 3-22  
microprocessor mode without internal memory, 3-21  
Microprocessor/Microcomputer Mode ( $\mu$ P/ $\mu$ C MODE) bit, 4-10  
Mode Control Pin Data (MC PIN DATA) bit, 4-10  
Mode Control Pin Write Protect Override (MC PIN WPO) status bit, 4-10  
MOV, Move Instruction, 13-24, 13-67  
move instructions, 13-67, 13-69  
MOVW, Move Word Instruction, 13-24, 13-69  
MPY, Multiply Instruction, 13-24, 13-70  
multiple interrupt servicing, 5-13

multiplication instructions, 13-70

## N

Negative (N) bit, 3-5  
nested interrupt routines, 5-13  
non-maskable interrupt, 5-7  
Non-Watchdog mode, 7-20  
NOP, No-Operation Instruction, 13-24, 13-71

## O

offset calculation, 13-8, 13-9  
offset indirect addressing modes, 13-15  
Offset Timer Definition-Time from Last Event, 12-12, 12-24  
Opcode Fetch (OCF) signal, 4-18  
opcode map, C-1  
Opcode/Instruction Cross Reference, D-1  
operating modes, memory, 3-15  
OR, Logical OR Instruction, 13-25, 13-72  
OSC FLT DISABLE bit, 4-3  
OSC FLT FLAG, 4-3  
OSC FLT RST ENA, 4-3  
OSC POWER bit, 4-9  
Oscillator Fault, 4-3  
Oscillator Fault Disable (OSC FLT DISABLE) bit, 4-13  
Oscillator Fault Flag (OSC FLT FLAG), 4-10  
Oscillator Fault Reset Enable (OSC FLT RST ENA), 4-13  
Oscillator Power (OSC POWER) bit, 4-11  
Overflow (V) bit, 3-5

## P

package pinouts, Appendix F  
packaging, 17-6  
PACT, 1-9, 12-1  
PACT Block Diagram, 12-37  
PACT Macro, Appendix G  
PACT prescaled clock, 12-8  
PACT-SCI Control Register, 12-45

- 
- PCH, 3-7
  - PCL, 3-7
  - Peripheral Addressing mode, 13-6
  - peripheral file (PF), 3-10
  - peripheral file address map, 3-11, Appendix A
  - Peripheral File Automatic Wait (PF AUTO WAIT) bit, 4-11
  - PF AUTO WAIT bit, 4-5
  - pin descriptions, TMS370Cx1x, 2-9
  - pin descriptions, TMS370Cx3x, 2-11
  - pin descriptions, TMS370Cx5x, 2-14
  - Pins
    - A/D pins, 11-5
    - AN0–AN7, 11-5
    - INT1, 5-7
    - INT2, 5-7
    - INT3, 5-7
    - MC, 3-15
    - RESET, 5-14
    - SCICLK, 9-7, 9-9
    - SPISIMO, 10-8
    - SPISOMI, 10-8
    - T2IC1/CR, 8-6, 8-10, 8-12
    - T2IC2/PWM, 8-6, 8-9, 8-10, 8-11
    - WAIT, 4-5
  - POP, POP from Stack Instruction, 13-25, 13-73
  - port D, 3-18
  - Powerdown mode, 4-6
  - Powerdown/Idle (PWRDWN/IDLE) bit, 4-14
  - PRESCALE, 12-40
  - prescale, 12-4
  - prescaled, 12-5
  - prescaled clock, 12-6
  - prescaler, 12-18
  - prescaler, Timer 1, 7-11
    - clock sources, 7-11
  - PRIVILEGE DISABLE bit, 4-2
  - Privilege Mode, 4-2
  - Privilege Mode Disable (PRIVILEGE DISABLE) bit, 4-13
  - Program Counter (PC), 3-7, 5-2
  - Program Counter Relative Addressing mode, 13-8
  - Program EEPROM, 1-8, 3-14
  - Program EEPROM Control Register (PEECTL), 3-14, 6-10
  - Program EEPROM module, 6-9
  - Program EEPROM write protection, 6-11
  - Program EPROM, 1-8, 6-12
  - Program EPROM Control Register (EPCTL), 6-13
  - program memory, 1-5, 3-12
  - program ROM, 3-13
  - programmer, 15-25
  - programming the Data EEPROM, 6-5
  - programming the Program EEPROM, 6-11
  - Programming the Program EPROM, 6-14
  - prototyping, 17-2
  - PUSH, Push on Stack Instruction, 13-25, 13-74
  - PWM Example, 12-34
  - PWRDWN/IDLE bit, 4-7
- R

  - ratiometric conversion, 11-6
  - Read or Write operation (R/W) signal, 4-18
  - reference documents, 1-13
  - Register Addressing mode, 13-5
  - Register B, 13-90
  - register file, 1-5, 1-8, 3-2
  - Register File (RF), 3-8
  - register-to-register architecture, 1-5
  - Registers
    - A,B, 13-89
    - A/D control registers, 11-10
    - ADCTL, 11-11
    - ADDATA, 11-14
    - ADENA, 11-16
    - ADIN, 11-15
    - ADPRI, 11-17
    - ADSTAT, 11-13
    - BAUD MSB, BAUD LSB, 9-24
    - DEECTL, 6-2, 6-4

external interrupt control, 5-7  
INT1, 5-10  
INT2, 5-11  
INT3, 5-12  
PC, 3-7  
PEECTL, 3-14  
RXBUF, 9-28  
RXCTL, 9-26  
SCCR0, 4-2, 4-10  
SCCR1, 4-2, 4-12  
SCCR2, 4-2, 4-13  
SCICCR, 9-20  
SCICTL, 9-22  
SCIPC1, 9-29  
SCIPC2, 9-30  
SCIPRI, 9-31  
SP, 3-3  
SPIBUF, 10-8, 10-15  
SPICCR, 10-8, 10-12  
SPICTL, 10-14  
SPIDAT, 10-8, 10-16  
SPIPC1, 10-17  
SPIPC2, 10-18  
SPIPRI, 10-20  
ST, 3-5  
T1CTL1, 7-26  
T1CTL2, 7-28  
T1CTL3, 7-30  
T1CTL4, 7-32  
T1PC1, 7-34  
T1PC2, 7-35  
T1PRI, 7-37  
T2CTL1, 8-18  
T2CTL2, 8-19  
T2CTL3, 8-21  
T2PC1, 8-23  
T2PC2, 8-24  
T2PRI, 8-26  
TXBUF, 9-14, 9-28  
TXCTL, 9-25  
TXSHF, 9-14  
WPR, 6-2, 6-3  
WUT, 9-14  
  
RESET, 3-15  
reset circuit, low voltage detect, 5-16  
reset circuit, typical, 5-16

RESET pin, 3-15  
reset sequence, 5-14  
reset sources, 5-14  
reset vectors, 3-13  
reset, control-bit states following, 5-15  
Return-From-Interrupt (RTI) instruction, 5-2  
RL, Rotate Left Instruction, 13-25, 13-75  
RLC, Rotate Left Through Carry Instruction, 13-25, 13-76  
ROM, program, 3-13  
rotate instructions, 13-75, 13-76, 13-77, 13-78  
RR, Rotate Right Instruction, 13-25, 13-77  
RRC, Rotate Right Through Carry Instruction, 13-25, 13-78  
RTI, Return From Interrupt Instruction, 13-25, 13-79  
RTS, Return From Subroutine Instruction, 13-25, 13-80

## S

SBB, Subtract with Borrow Instruction, 13-25, 13-81  
SBIT0, Set Bit to 0 Instruction, 13-26, 13-82  
SBIT1, Set Bit to 1 Instruction, 13-26, 13-83  
SCI, 12-33  
Serial Communications Interface (SCI), 1-9  
  address bit format, 9-15  
  address bit mode, 9-11, 9-14  
  ADDRESS/IDLE WUP bit, 9-12  
  ASYNC/ISOSYNC bit, 9-8  
  asynchronous format, 9-9  
  asynchronous mode, 9-4, 9-8  
  baud rates, 9-7  
  baud select registers (BAUD MSB and BAUD LSB), 9-24  
  block diagram, 9-3  
  BRKDT flag, 9-6  
  CLOCK bit, 9-7, 9-9  
  clock sources, 9-7  
  communication control register (SCICCR), 9-20  
  control register (SCICTL), 9-22

- control registers, 9-5, 9-19
- data format, 9-6
- features, 9-3
- idle line format, 9-13
- idle line mode, 9-11, 9-12
- interrupts, 9-6
- isochronous format, 9-9
- isochronous mode, 9-4, 9-9
- memory map, 9-5
- multiprocessor communications, 9-11
- multiprocessor protocols, 9-4
- operation, 9-6
- operation modes, 9-4
- overview, 9-2
- physical description, 9-2
- port control register 1 (SCIPC1), 9-29
- port control register 2 (SCIPC2), 9-30
- priority control register (SCIPRI), 9-31
- receiver data buffer register (RXBUF), 9-28
- receiver interrupt control and status register (RXCTL), 9-26
- Receiver Wakeup Detect (RXWAKE), 9-26
- RS-232-C example, 9-16
- RS-232-C multiprocessor example, 9-17
- RXRDY flag, 9-6
- SCI Break Detect Flag (BRKDT), 9-27
- SCI Character Length Control Bits (SCI CHAR0–2), 9-20
- SCI communication modes, 9-8
- SCI Communications Mode Control bit (ASYN/ISOSYN), 9-21
- SCI Framing Error Flag (FE), 9-26
- SCI Internal Clock Enable (CLOCK), 9-22
- SCI Multiprocessor Mode Control bit (ADDRESS/IDLE WUP), 9-20
- SCI Number of Stop Bits (STOP BITS), 9-21
- SCI Overrun Error Flag (OE), 9-26
- SCI Parity Enable bit (PARITY ENABLE), 9-21
- SCI Parity Error Flag (PE), 9-26
- SCI Parity Odd/Even (EVEN/ODD PARITY), 9-21
- SCI Receive Enable (RXENA), 9-22
- SCI Receiver Error Flag (RX ERROR), 9-27
- SCI Receiver Interrupt Enable (SCI RX INT ENA), 9-26
- SCI Receiver Interrupt Priority (SCI RX PRIORITY), 9-31
- SCI Receiver Ready (RXRDY), 9-27
- SCI RX PRIORITY bit, 9-6
- SCI Sleep (SLEEP), 9-22
- SCI Software Reset (SCI SW RESET), 9-23
- SCI Transmit Enable (TXENA), 9-22
- SCI Transmitter Empty (TX EMPTY), 9-25
- SCI Transmitter Interrupt Priority (SCI TX PRIORITY), 9-31
- SCI Transmitter Ready (TXRDY), 9-25
- SCI Transmitter Ready Interrupt (SCI TX INT ENA), 9-25
- SCI Transmitter Wake-up (TXWAKE), 9-22
- SCI TX PRIORITY bit, 9-6
- SCICLK Data Direction (SCICLK DATA DIR), 9-29
- SCICLK DATA IN, 9-29
- SCICLK DATA IN bit, 9-7
- SCICLK DATA OUT, 9-29
- SCICLK FUNCTION bit, 9-7, 9-9, 9-29
- SCIRXD Data Direction (SCIRXD DATA DIR), 9-30
- SCIRXD DATA IN, 9-30
- SCIRXD DATA OUT, 9-30
- SCIRXD FUNCTION, 9-30
- SCITXD Data Direction (SCITXD DATA DIR), 9-30
- SCITXD DATA IN, 9-30
- SCITXD DATA OUT, 9-30
- SCITXD FUNCTION, 9-30
- serial clock rates, 9-7
- SLEEP bit, 9-12, 9-13
- transmit data buffer register (TXBUF), 9-28
- transmitter interrupt control and status register (TXCTL), 9-25
- TXRDY flag, 9-6
- TXWAKE bit, 9-13, 9-14
- WUT flag, 9-13

- Serial Peripheral Interface (SPI), 1-10
  - block diagram, 10-3
  - character length, 10-5
  - character length control bits (CHAR0–2), 10-12
  - CLOCK POLARITY bit, 10-7
  - clock sources, 10-7
  - Configuration Control register (SPICCR), 10-12
  - control registers, 10-4, 10-11
  - data format, 10-5
  - Emulator Suspend Enable (SPI ESPEN), 10-20
  - Enable Network Master (MASTER/SLAVE), 10-14
  - example, 10-10
  - initialization, 10-9
  - interrupt priority control register (SPIPRI), 10-20
  - Interrupt Priority Select (SPI PRIORITY), 10-20
  - interrupts, 10-6
  - master mode, 10-8
  - MASTER/SLAVE bit, 10-8
  - master/slave connection, 10-5
  - Master/Slave Transmit Enable (TALK), 10-14
  - memory map, 10-4
  - operation, 10-5
  - operation control register (SPICTL), 10-14
  - overview, 10-2
  - physical description, 10-2
  - port control register 1 (SPIPC1), 10-17
  - port control register 2 (SPIPC2), 10-18
  - RECEIVER OVERRUN bit, 10-7, 10-14
  - serial data register (SPIDAT), 10-16
  - serial input buffer (SPIBUF), 10-15
  - Serial Peripheral Interrupt Flag (SPI INT FLAG), 10-14
  - Shift Clock Polarity (CLOCK POLARITY), 10-13
  - slave mode, 10-8
  - SPI BIT RATE bits, 10-7
  - SPI Bit Rate Control Bits (SPI BIT RATE0–2), 10-13
  - SPI INT ENA bit, 10-6, 10-8
  - SPI INT FLAG, 10-7, 10-8
  - SPI Interrupt Enable (SPI INT ENA), 10-14
  - SPI operating modes, 10-8
  - SPI PRIORITY bit, 10-6
  - SPI STEST, 10-20
  - SPI SW RESET bit, 10-9, 10-13
  - SPIBUF register, 10-8
  - SPICCR register, 10-8
  - SPICLK Data Direction (SPICLK DATA DIR), 10-17
  - SPICLK Pin Function Select (SPICLK FUNCTION), 10-17
  - SPICLK Pin Port Data In (SPICLK DATA IN), 10-17
  - SPICLK Port Data Out (SPICLK DATA OUT), 10-17
  - SPIDAT register, 10-8
  - SPISIMO Data Direction (SPISIMO DATA DIR), 10-18
  - SPISIMO Pin Data In (SPISIMO DATA IN), 10-19
  - SPISIMO Pin Data Out (SPISIMO DATA OUT), 10-18
  - SPISIMO Pin Function Select (SPISIMO FUNCTION), 10-18
  - SPISOMI Data Direction (SPISOMI DATA DIR), 10-18
  - SPISOMI Pin Data In (SPISOMI DATA IN), 10-18
  - SPISOMI Pin Data Out (SPISOMI DATA OUT), 10-18
  - SPISOMI Pin Function Select (SPISOMI FUNCTION), 10-18
  - TALK bit, 10-9
- set, 1-12
- SETC, Set Carry Instruction, 13-26, 13-84
- Signals
  - CLKOUT, 4-18
  - CSE1, 3-18, 4-18
  - CSE2, 3-18, 4-18
  - CSH1, 4-17
  - CSH2, 4-17
  - CSH3, 4-18
  - CSPF, 3-18, 4-18
  - EDS, 3-19, 3-21, 3-22, 4-17
  - OCF, 4-18



- R/W, 4-18
- RESET, 3-15
- WAIT, 4-18
- WPO, 3-14
- SPI, 1-10
- stack, 3-2, 5-2
- stack operations, 13-73, 13-74, 13-85
- Stack Pointer (SP), 3-3, 13-65, 13-85
- Stack Pointer Relative Addressing mode, 13-9
- Standard Compare Command, 12-9, 12-25
- Standby mode, 4-6, 4-7
- status and control bits
  - AD ESPEN, 11-17
  - AD INPUT SELECT0–2, 11-11
  - AD INT ENA, 11-6, 11-13
  - AD INT FLAG, 11-6, 11-13
  - AD PRIORITY, 11-6, 11-17
  - AD READY, 11-13
  - AD STEST, 11-17
  - ADDRESS/IDLE WUP, 9-20
  - AP, 6-4, 6-10, 6-11
  - ASYNC/ISOSYNC, 9-21
  - AUTOWAIT DISABLE, 4-5, 4-12
  - BRKDT, 9-6, 9-27
  - BUS STEST, 4-13
  - BUSY, 6-5, 6-7, 6-10, 6-13
  - C, 3-5
  - CHAR0–2, 10-12
  - CLOCK, 9-7, 9-9, 9-22
  - CLOCK POLARITY, 10-7, 10-13
  - COLD START, 4-11
  - CONVERT START, 11-7, 11-12
  - CPU STEST, 4-13
  - DATA7–DATA0, 11-14
  - EVEN/ODD PARITY, 9-21
  - EXE, 6-4, 6-10, 6-13
  - FE, 9-26
  - HALT/STANDBY, 4-7, 4-14
  - IE1, 3-5
  - IE1 & IE2, 5-13
  - IE2, 3-5
  - INT DATA DIR, 5-8
  - INT DATA OUT, 5-8
  - INT ENABLE, 5-8
  - INT FLAG, 5-8
  - INT PIN DATA, 5-8
  - INT POLARITY, 5-8
  - INT PRIORITY, 5-8
  - INT1 ENABLE, 5-10
  - INT1 FLAG, 5-10
  - INT1 NMI, 4-13
  - INT1 PIN DATA, 5-10
  - INT1 POLARITY, 5-10
  - INT1 PRIORITY, 5-10
  - INT2 DATA DIR, 5-11
  - INT2 DATA OUT, 5-11
  - INT2 ENABLE, 5-11
  - INT2 FLAG, 5-11
  - INT2 PIN DATA, 5-11
  - INT2 POLARITY, 5-11
  - INT2 PRIORITY, 5-11
  - INT3 DATA DIR, 5-12
  - INT3 DATA OUT, 5-12
  - INT3 ENABLE, 5-12
  - INT3 FLAG, 5-12
  - INT3 PIN DATA, 5-12
  - INT3 POLARITY, 5-12
  - INT3 PRIORITY, 5-12
  - MASTER/SLAVE, 10-8, 10-14
  - MC PIN DATA, 4-10
  - MC PIN WPO bit, 4-10
  - MEMORY DISABLE, 3-22, 4-12
  - μP/μC MODE, 4-10
  - N, 3-5
  - OE, 9-26
  - OSC FLT DISABLE, 4-4, 4-13
  - OSC FLT FLAG, 4-4, 4-10
  - OSC FLT RST ENA, 4-4, 4-13
  - OSC POWER, 4-9, 4-11
  - PACT RXDT 0–7, 12-46
  - PACT TXDT 0–7, 12-46
  - PARITY ENABLE, 9-21
  - PE, 9-26
  - PF AUTO WAIT, 4-5, 4-11
  - PORT E DATA AN7–PORT E DATA AN 0, 11-15
  - PORT E INPUT ENA 7–PORT E INPUT ENA 0, 11-16
  - POWERDOWN/IDLE, 8-15
  - PRIVILEGE DISABLE, 4-2, 4-13
  - PWRDWN/IDLE, 4-7, 4-14

RECEIVER/OVERRUN, 10-14  
REF VOLT SELECT0–2, 11-11  
RX ERROR, 9-27  
RXENA, 9-22  
RXRDY, 9-6, 9-27  
RXWAKE, 9-26  
SAMPLE START, 11-7, 11-12  
SCI STEST, 9-31  
SCI CHAR0–2, 9-20  
SCI Emulator Suspend Enable (SCI  
  ESPEN), 9-31  
SCI ESPEN, 9-31  
SCI RX INT ENA, 9-26  
SCI RX PRIORITY, 9-6, 9-31  
SCI SW RESET, 9-23  
SCI TX INT ENA, 9-25  
SCI TX PRIORITY, 9-6, 9-31  
SCICLK DATA DIR, 9-29  
SCICLK DATA IN, 9-7, 9-29, 9-31  
SCICLK DATA OUT, 9-29  
SCICLK FUNCTION, 9-9, 9-29  
SCIRXD DATA DIR, 9-30  
SCIRXD DATA IN, 9-30  
SCIRXD DATA OUT, 9-30  
SCIRXD FUNCTION, 9-30  
SCITXD DATA DIR, 9-30  
SCITXD DATA IN, 9-30  
SCITXD DATA OUT, 9-30  
SCITXD FUNCTION, 9-30  
SLEEP, 9-13, 9-14, 9-22  
SPI BIT RATE0–2, 10-7, 10-13  
SPI ESPEN, 10-20  
SPI INT ENA, 10-6, 10-8, 10-14  
SPI INT FLAG, 10-6, 10-7, 10-14  
SPI PRIORITY, 10-6, 10-20  
SPI RECEIVER OVERRUN, 10-7  
SPI STEST, 10-20  
SPI SW RESET, 10-9, 10-13  
SPICLK DATA DIR, 10-17  
SPICLK DATA IN, 10-17  
SPICLK DATA OUT, 10-17  
SPICLK FUNCTION, 10-17  
SPISIMO DATA DIR, 10-18  
SPISIMO DATA IN, 10-19  
SPISIMO DATA OUT, 10-18  
SPISIMO FUNCTION, 10-18  
SPISOMI DATA DIR, 10-18  
SPISOMI DATA IN, 10-18  
SPISOMI DATA OUT, 10-18  
SPISOMI FUNCTION, 10-18  
STOP BITS, 9-21  
T1 INPUT SELECT 0–2, 7-26  
T1 MODE, 7-33  
T1 OVRFL INT ENA, 7-28  
T1 OVRFL INT FLAG, 7-28  
T1 PRIORITY, 7-37  
T1 SW RESET, 7-28  
T1C1 INT ENA, 7-30  
T1C1 INT FLAG, 7-31  
T1C1 OUT ENA, 7-33  
T1C1 RST ENA, 7-33  
T1C2 INT ENA, 7-30  
T1C2 INT FLAG, 7-31  
T1C2 OUT ENA, 7-33  
T1CR OUT ENA, 7-33  
T1CR RST ENA, 7-33  
T1EDGE DET ENA, 7-32  
T1EDGE INT ENA, 7-30  
T1EDGE INT FLAG, 7-31  
T1EDGE POLARITY, 7-8, 7-33  
T1EVT DATA DIR, 7-34  
T1EVT DATA IN, 7-34  
T1EVT DATA OUT, 7-34  
T1EVT FUNCTION, 7-34  
T1IC/CR DATA DIR, 7-35  
T1IC/CR DATA IN, 7-35  
T1IC/CR DATA OUT, 7-35  
T1IC/CR FUNCTION, 7-35  
T1PWM DATA DIR, 7-35  
T1PWM DATA IN, 7-36  
T1PWM DATA OUT, 7-36  
T1PWM FUNCTION, 7-35  
T2 INPUT SELECT0-1, 8-8, 8-18  
T2 MODE, 8-22  
T2 OVRFL INT ENA, 8-18  
T2 OVRFL INT FLAG, 8-10, 8-18  
T2 PRIORITY, 8-26  
T2 STEST, 8-26  
T2 SW RESET, 8-10, 8-18  
T2C1 INT ENA, 8-19  
T2C1 INT FLAG, 8-11, 8-20  
T2C1 OUT ENA, 8-22  
T2C1 RST ENA, 8-22  
T2C2 INT ENA, 8-19

- T2C2 INT FLAG, 8-12, 8-20
  - T2C2 OUT ENA, 8-22
  - T2EDGE1 DET ENA, 8-9, 8-12, 8-21
  - T2EDGE1 INT ENA, 8-19
  - T2EDGE1 INT FLAG, 8-9, 8-10, 8-12, 8-20
  - T2EDGE1 OUT ENA, 8-9, 8-22
  - T2EDGE1 POLARITY, 8-9, 8-22, 10-11
  - T2EDGE1 RST ENA, 8-9, 8-21
  - T2EDGE2 DET ENA, 8-21
  - T2EDGE2 INT ENA, 8-19
  - T2EDGE2 INT FLAG, 8-10, 8-11, 8-20
  - T2EDGE2 POLARITY, 8-22
  - T2EVT DATA DIR, 8-23
  - T2EVT DATA IN, 8-23
  - T2EVT DATA OUT, 8-23
  - T2EVT FUNCTION, 8-23
  - T2IC1/CR DATA DIR, 8-24
  - T2IC1/CR DATA IN, 8-24
  - T2IC1/CR DATA OUT, 8-24
  - T2IC1/CR FUNCTION, 8-24
  - T2IC2/PWM DATA DIR, 8-24
  - T2IC2/PWM DATA IN, 8-25
  - T2IC2/PWM DATA OUT, 8-25
  - T2IC2/PWM FUNCTION, 8-24
  - T2OVRFL INT ENA, 8-10
  - TALK, 10-9, 10-14
  - TX EMPTY, 9-25
  - TXENA, 9-22
  - TXRDY, 9-6, 9-25
  - TXWAKE, 9-14, 9-15, 9-22
  - V, 3-5
  - VPPS, 6-13
  - W0, 6-13
  - W1W0, 6-4, 6-10
  - WD INPUT SELECT 0–2, 7-26
  - WD OVRFL INT ENA, 7-28
  - WD OVRFL INT FLAG, 7-28
  - WD OVRFL RST ENA, 7-29
  - WD OVRFL TAP SEL, 7-27
  - WUT, 9-14
  - Z, 3-5
  - Status Register (ST), 3-5, 5-2, 13-66
  - STSP, Store Stack Pointer Instruction, 13-26, 13-85
  - SUB, Subtract Instruction, 13-26, 13-86
  - subroutine instructions, 13-38, 13-39, 13-80, 13-88
  - subtraction instructions, 13-47, 13-51, 13-81, 13-82, 13-83, 13-86
  - SWAP, Swap Nibbles Instruction, 13-26, 13-87
  - symbols, used in this manual, 1-12
  - system configuration, 4-2
  - System Control and Configuration Register 0 (SCCR0), 4-2, 4-10
  - System Control and Configuration Register 1 (SCCR1), 4-2, 4-12
  - System Control and Configuration Register 2 (SCCR2), 4-2, 4-13
  - System Control registers, 4-10
  - system interface example, 4-22
- ## T
- TI EEPROM Programmer, 15-25
  - time base, 12-4
  - time slot, 12-16
  - Timer 1, 1-9, 7-2
    - capture, 7-6
    - clock prescaler, 7-11
    - compare, 7-6
    - compare register, 7-16
    - control registers, 7-24
    - counter duration, 7-12
    - counter resolution, 7-12
    - dual compare mode, 7-6, 7-9
    - edge detection, 7-13
    - external clock input, 7-11
    - general purpose timer, 7-7
    - halt, 7-23
    - interrupt flags, 7-18
    - interrupts, 7-3, 7-18
    - low-power modes, 7-23
    - operating modes, 7-6
    - pulse accumulation, 7-13
    - reset sources, 7-9
    - Standby, 7-23
  - T1EVT, 7-3
  - T1EVT Pin Data In bit (T1EVT DATA IN), 7-34

- T1EVT Pin Data Out bit (T1EVT DATA OUT), 7-34
- T1EVT Pin Function Select bit (T1EVT FUNCTION), 7-34
- T1IC/CR, 7-3
- T1IC/CR Pin Data Direction bit (T1IC/CR DATA DIR), 7-35
- T1IC/CR Pin Data In bit (T1IC/CR DATA IN), 7-35
- T1IC/CR Pin Data Out bit (T1IC/CR DATA OUT), 7-35
- T1IC/CR Pin Function Select bit (T1IC/CR FUNCTION), 7-35
- T1PWM, 7-3
- T1PWM Data Direction bit (T1PWM DATA DIR), 7-35
- T1PWM Function Select bit (T1PWM FUNCTION), 7-35
- T1PWM Pin Data In bit (T1PWM DATA IN), 7-36
- T1PWM Pin Data Out bit (T1PWM DATA OUT), 7-36
- watchdog counter memory map, 7-5
- watchdog counter overflow rates, 7-12
- Timer 1 Compare 1 Interrupt Enable bit (T1C1 INT ENA), 7-30
- Timer 1 Compare 1 Interrupt Flag (T1C1 INT FLAG), 7-31
- Timer 1 Compare 1 Reset Enable bit (T1C1 RST ENA), 7-33
- Timer 1 Compare 2 Interrupt Enable bit (T1C2 INT ENA), 7-30
- Timer 1 Compare 2 Interrupt Flag bit (T1C2 INT FLAG), 7-31
- Timer 1 Counter Control Register 1 (T1CTL1), 7-26
- Timer 1 Counter Control Register 2 (T1CTL2), 7-28
- Timer 1 Counter Control Register 3 (T1CTL3), 7-30
- Timer 1 Counter Control Register 4 (T1CTL4), 7-32
- Timer 1 Edge Detect Enable bit (T1EDGE DET ENA), 7-32
- Timer 1 Edge Interrupt Enable bit (T1EDGE INT ENA), 7-30
- Timer 1 Edge Interrupt Flag bit (T1EDGE INT FLAG), 7-31
- Timer 1 Edge Polarity bit (T1EDGE POLARITY), 7-33
- Timer 1 Event-Pin Data Direction bit (T1EVT DATA DIR), 7-34
- Timer 1 External Edge Output Enable bit (T1CR OUT ENA), 7-33
- Timer 1 External Reset Enable bit (T1CR RST ENA), 7-33
- Timer 1 Input Select bits (T1 INPUT SELECT 0-2), 7-26
- Timer 1 Interrupt Priority Control Register (T1PRI), 7-37
- Timer 1 Interrupt Priority Select bit (T1 PRIORITY), 7-37
- Timer 1 Mode Select bit (T1MODE), 7-33
- Timer 1 Output-Compare Output Enable 1 bit (T1C1 OUT ENA), 7-33
- Timer 1 Output-Compare Output Enable 2 bit (T1C2 OUT ENA), 7-33
- Timer 1 Overflow Interrupt Enable bit (T1 OVRFL INT ENA), 7-28
- Timer 1 Overflow Interrupt Flag (T1 OVRFL INT FLAG), 7-28
- Timer 1 Port Control Register 1 (T1PC1), 7-34
- Timer 1 Port Control Register 2 (T1PC2), 7-35
- Timer 1 Software Reset bit (T1 SW RESET), 7-28
- Timer 2, 1-9
  - 16-bit resettable up counter, 8-10
  - block diagram, 8-2
  - capture register, 8-11
  - capture/compare register, 8-12
  - clearing interrupt flags, 8-14
  - clock sources, 8-8
  - compare register, 8-11
  - control register 1 (T2CTL1), 8-18
  - control register 2 (T2CTL2), 8-19
  - control register 3 (T2CTL3), 8-21
  - control registers, 8-4, 8-16

- dual capture mode, 8-4, 8-6
- dual compare mode, 8-3, 8-6
- edge detection in dual capture mode, 8-10
- edge detection in dual compare mode, 8-9
- event counter mode, 8-8
- features, 8-3
- I/O pin functions, 8-13
- I/O pins, 8-2
- interrupt priority register 2 (T2PRI), 8-26
- interrupts, 8-14
- maximum counter duration, 8-8
- memory map, 8-4
- operating modes, 8-3, 8-5
- port control register 1 (T2PC1), 8-23
- port control register 2 (T2PC2), 8-24
- power-down modes, 8-15
- POWERDOWN/IDLE bit, 8-15
- pulse accumulator mode, 8-8
- T2 OVRFL INT FLAG bit, 8-10
- T2 SW RESET bit, 8-10
- T2C1 INT FLAG bit, 8-11
- T2C2 INT FLAG bit, 8-12
- T2EDGE1 DET ENA bit, 8-12
- T2EDGE1 INT FLAG bit, 8-12
- T2EDGE2 INT FLAG bit, 8-11
- T2EDGE2 POLARITY bit, 8-10
- T2IC1/CR pin, 8-12
- T2IC2/PWM pin, 8-11
- T2OVRFL INT ENA bit, 8-10
- Timer 2 Compare 1 Interrupt Enable (T2C1 INT ENA), 8-19
- Timer 2 Edge 1 Detect Enable (T2EDGE1 DET ENA), 8-12, 8-21
- Timer 2 Edge 1 Detect Output Enable (T2EDGE1 OUT ENA), 8-22
- Timer 2 Edge 1 Detect Reset Enable (T2EDGE1 RST ENA), 8-21
- Timer 2 Edge 1 Polarity Select (T2EDGE1 POLARITY), 8-22
- Timer 2 Edge 2 Interrupt Flag (T2EDGE2 INT FLAG), 8-20
- Timer 2 Edge 2 Polarity Select (T2EDGE2 POLARITY), 8-22
- Timer 2 Event Pin Data Direction (T2EVT DATA DIR), 8-23
- Timer 2 Event Pin Data In (T2EVT DATA IN), 8-23
- Timer 2 Event Pin Data Out (T2EVT DATA OUT), 8-23
- Timer 2 Event Pin Function Select (T2EVT FUNCTION), 8-23
- Timer 2 External Edge 1 Interrupt (T2EDGE1 INT ENA), 8-19
- Timer 2 External Edge 1 Interrupt (T2EDGE1 INT FLAG), 8-20
- Timer 2 External Edge 2 Detect Enable (T2EDGE2 DET ENA), 8-21
- Timer 2 External Edge 2 Interrupt Enable (T2EDGE2 INT ENA), 8-19
- Timer 2 IC1/CR Data Direction (T2IC1/CR DATA DIR), 8-24
- Timer 2 IC1/CR Data In (T2IC1/CR DATA IN), 8-24
- Timer 2 IC1/CR Data Out (T2IC1/CR DATA OUT), 8-24
- Timer 2 IC1/CR Function Select (T2IC1/CR FUNCTION), 8-24
- Timer 2 IC2/PWM Data Direction (T2IC2/PWM DATA DIR), 8-24
- Timer 2 IC2/PWM Data In (T2IC2/PWM DATA IN), 8-25
- Timer 2 IC2/PWM Data Out (T2IC2/PWM DATA OUT), 8-25
- Timer 2 IC2/PWM Function (T2IC2/PWM FUNCTION), 8-24
- Timer 2 Input Select bits (T2 INPUT SELECT 0, 1), 8-18
- Timer 2 Interrupt Priority Select (T2 PRIORITY), 8-26
- Timer 2 Mode Select (T2 MODE), 8-22
- Timer 2 Output Compare 1 Enable (T2C1 OUT ENA), 8-22
- Timer 2 Output Compare 1 Interrupt (T2C1 INT FLAG), 8-20
- Timer 2 Output Compare 1 Reset (T2C1 RST ENA), 8-22
- Timer 2 Output Compare 2 Enable (T2C2 OUT ENA), 8-22
- Timer 2 Output Compare 2 Interrupt Enable (T2C2 INT ENA), 8-19
- Timer 2 Output Compare 2 Interrupt Flag (T2C2 INT FLAG), 8-20

- Timer 2 Overflow Interrupt Enable (T2 OVRFL INT ENA), 8-18
- Timer 2 Overflow Interrupt Flag (T2 OVRFL INT FLAG), 8-18
- Timer 2 Software Reset bit (T2 SW RESET), 8-18
- Timer 2 module, 8-1
- timer, watchdog, 1-9
- TMS370 devices, 15-3
- TMS370 family devices summary, 2-1
- TMS370 family features, 1-3
- TMS370Cx1x features, 2-7
- TMS370Cx3x features, 2-7
- TMS370Cx5x features, 2-8
- TRAP, Trap to Subroutine Instruction, 13-88
- Trap n, Trap to Subroutine Instruction, 13-26
- trap vectors, 3-13
- TST
  - Test Instruction, 13-26
  - Test, Set Flags from Register Instruction, 13-89

## V

- vector addresses, interrupts, 5-6
- virtual timer definition, 12-22
- virtual timers, 12-10

## W

- WAIT input (WAIT) signal, 4-18
- WAIT pin, 4-4
- wait states, 4-4
- Watchdog, 12-32
- watchdog counter memory map, 7-5
- Watchdog Input Select bits (WD INPUT SELECT 0–2), 7-26
- Watchdog Overflow Interrupt Enable bit (WD OVRFL INT ENA), 7-28
- Watchdog Overflow Interrupt Flag (WD OVRFL INT FLAG), 7-28

- Watchdog Overflow Reset Enable bit (WD OVRFL RST ENA), 7-29
- Watchdog Overflow Tap Select bit (WD OVRFL TAP SEL), 7-27
- Watchdog Timer, 1-9, 7-19
  - control registers, 7-24
  - counter, 7-19
  - halt, 7-23
  - initialization example, 7-21
  - low-power modes, 7-23
  - non-watchdog mode, 7-22
  - overflow flag, 7-22
  - power-up reset, 7-21
  - reset frequency, 7-22
  - reset key, 7-20
  - standby, 7-23
  - Watchdog mode, 7-19
  - WD OVRFL INT FLAG, 7-20
  - WD OVRFL RST ENA, 7-19, 7-20, 7-21
  - WD OVRFL TAP SEL, 7-20, 7-22
  - WDRST, 7-20
- WD OVRFL INT ENA, 7-28
- WPR (register), 6-2
- Write Protect Override (WPO), 3-14
- write protecting Program EEPROM, 6-11
- Write Protection Override (WPO) mode, 6-3
- Write Protection Register (WPR), 6-3
- write-protection bits, 6-3
- Write0 (W0) bit, 6-13
- Write1/Write0 (W1W0) bit, 6-4, 6-10

## X

- XCHB, Exchange with Register B Instruction, 13-26, 13-90
- XDS, 1-2, 15-8
  - ordering information, 17-15
- XDS System, 15-8
- XOR, Exclusive OR Instruction, 13-26, 13-91

## Z

- Zero (Z) bit, 3-5

# TI Sales Offices

**ALABAMA:** Huntsville (205) 837-7530.  
**ARIZONA:** Phoenix (602) 995-1007; Tucson (602) 292-2640.  
**CALIFORNIA:** Irvine (714) 860-1200; Roseville (916) 786-9208; San Diego (619) 278-9601; Santa Clara (408) 980-9000; Torrance (213) 217-7010; Woodland Hills (818) 704-7759.  
**COLORADO:** Aurora (303) 368-8000.  
**CONNECTICUT:** Wallingford (203) 269-0074.  
**FLORIDA:** Altamonte Springs (305) 260-2116; Ft. Lauderdale (305) 973-8502; Tampa (813) 885-7411.  
**GEORGIA:** Norcross (404) 662-7900.  
**ILLINOIS:** Arlington Heights (312) 640-2925.  
**INDIANA:** Carmel (317) 573-6400; Ft. Wayne (219) 424-5174.  
**IOWA:** Cedar Rapids (319) 395-9550.  
**KANSAS:** Overland Park (913) 451-4511.  
**MARYLAND:** Columbia (301) 964-2003.  
**MASSACHUSETTS:** Waltham (617) 895-9100.  
**MICHIGAN:** Farmington Hills (313) 553-1569; Grand Rapids (616) 957-4200.  
**MINNESOTA:** Eden Prairie (612) 828-9300.  
**MISSOURI:** St. Louis (314) 569-7600.  
**NEW JERSEY:** Iselin (201) 750-1050.  
**NEW MEXICO:** Albuquerque (505) 345-2555.  
**NEW YORK:** East Syracuse (315) 463-9291; Melville (516) 454-6600; Pittsford (716) 365-7700; Poughkeepsie (914) 473-2900.  
**NORTH CAROLINA:** Charlotte (704) 527-0933; Raleigh (919) 876-2725.  
**OHIO:** Beachwood (216) 464-6100; Beaver Creek (613) 427-6200.  
**OREGON:** Beaverton (503) 643-6758.  
**PENNSYLVANIA:** Blue Bell (215) 825-9500.  
**PUERTO RICO:** Hato Rey (809) 753-8700.  
**TENNESSEE:** Johnson City (615) 461-2192.  
**TEXAS:** Austin (512) 250-7655; Houston (713) 778-6592; Richardson (214) 680-5082; San Antonio (512) 496-1779.  
**UTAH:** Murray (801) 266-8972.  
**WASHINGTON:** Redmond (206) 881-3080.  
**WISCONSIN:** Brookfield (414) 782-2899.  
**CANADA:** Nepean, Ontario (613) 726-1970; Richmond Hill, Ontario (416) 884-9181; St. Laurent, Quebec (514) 336-1860.

# TI Regional Technology Centers

**CALIFORNIA:** Irvine (714) 860-8105; Santa Clara (408) 748-2220.  
**GEORGIA:** Norcross (404) 662-7945.  
**ILLINOIS:** Arlington Heights (312) 640-2909.  
**MASSACHUSETTS:** Waltham (617) 895-9196.  
**TEXAS:** Richardson (214) 680-5066.  
**CANADA:** Nepean, Ontario (613) 726-1970.

# TI Distributors

**TI AUTHORIZED DISTRIBUTORS**  
**Arrow/Kierulff Electronics Group**  
**Arrow (Canada)**  
**Future Electronics (Canada)**  
**GRS Electronics Co., Inc.**  
**Hall-Mark Electronics**  
**Marshall Industries**  
**Newark Electronics**  
**Schweber Electronics**  
**Time Electronics**  
**Wyle Laboratories**  
**Zeus Components**

**- OBSOLETE PRODUCT ONLY -**  
**Rochester Electronics, Inc.**  
**Newburyport, Massachusetts**  
**(508) 462-9332**

**ALABAMA:** Arrow/Kierulff (205) 837-6955; Hall-Mark (205) 837-8700; Marshall (205) 881-9235; Schweber (205) 895-0480.  
**ARIZONA:** Arrow/Kierulff (602) 437-0750; Hall-Mark (602) 437-1200; Marshall (602) 496-0290; Schweber (602) 431-0030; Wyle (602) 866-2888.  
**CALIFORNIA:** Los Angeles/Orange County: Arrow/Kierulff (818) 701-7500, (714) 838-5422; Hall-Mark (818) 713-4500, (714) 665-4100; Marshall (818) 407-0101, (818) 459-5500, (714) 458-5395; Schweber (818) 880-9686; (714) 863-0200, (213) 320-8090; Wyle (818) 880-9000, (714) 863-9953; Zeus (714) 921-9000; (818) 889-3838; Sacramento: Hall-Mark (916) 624-3781; Marshall (916) 635-9700; Schweber (916) 364-0222; Wyle (916) 638-5282; San Diego: Arrow/Kierulff (619) 565-4800; Hall-Mark (619) 268-1201; Marshall (619) 578-9600; Schweber (619) 450-0454; Wyle (619) 565-9171; San Francisco Bay Area: Arrow/Kierulff (408) 745-6600; Hall-Mark (408) 432-0900; Marshall (408) 942-4600; Schweber (408) 432-7171; Wyle (408) 727-2500; Zeus (408) 998-5121.  
**COLORADO:** Arrow/Kierulff (303) 790-4444; Hall-Mark (303) 790-1662; Marshall (303) 451-8383; Schweber (303) 799-0258; Wyle (303) 457-9953.  
**CONNECTICUT:** Arrow/Kierulff (203) 265-7741; Hall-Mark (203) 271-2844; Marshall (203) 265-3822; Schweber (203) 264-4700.  
**FLORIDA:** Ft. Lauderdale: Arrow/Kierulff (305) 429-8200; Hall-Mark (305) 971-9280; Marshall (305) 977-4880; Schweber (305) 977-7511; Orlando: Arrow/Kierulff (407) 323-0252; Hall-Mark (407) 830-5855; Marshall (407) 767-8585; Schweber (407) 331-7555; Zeus (407) 365-3000; Tampa: Hall-Mark (813) 530-4543; Marshall (813) 576-1399; Schweber (813) 541-5100.  
**GEORGIA:** Arrow/Kierulff (404) 449-8252; Hall-Mark (404) 447-8000; Marshall (404) 923-5750; Schweber (404) 449-9170.  
**ILLINOIS:** Arrow/Kierulff (312) 250-0500; Hall-Mark (312) 860-3800; Marshall (312) 490-0155; Newark (312) 784-5100; Schweber (312) 364-3750.  
**INDIANA:** Indianapolis: Arrow/Kierulff (317) 243-9353; Hall-Mark (317) 872-8875; Marshall (317) 297-0483; Schweber (317) 843-1050.  
**IOWA:** Arrow/Kierulff (319) 395-7230; Schweber (319) 373-1417.  
**KANSAS:** Kansas City: Arrow/Kierulff (913) 541-9542; Hall-Mark (913) 888-4747; Marshall (913) 492-3121; Schweber (913) 492-2922.

**MARYLAND:** Arrow/Kierulff (301) 985-8002; Hall-Mark (301) 988-9800; Marshall (301) 235-9464; Schweber (301) 840-5900; Zeus (301) 997-1118.  
**MASSACHUSETTS:** Arrow/Kierulff (508) 658-0900; Hall-Mark (508) 667-0902; Marshall (508) 658-0810; Schweber (617) 275-5100; Time (617) 532-6200; Wyle (617) 273-7300; Zeus (617) 863-8800.  
**MICHIGAN:** Detroit: Arrow/Kierulff (313) 462-2290; Hall-Mark (313) 462-1205; Marshall (313) 525-5850; Newark (313) 987-0600; Schweber (313) 565-8100; Grand Rapids: Arrow/Kierulff (616) 243-0912.  
**MINNESOTA:** Arrow/Kierulff (612) 830-1800; Hall-Mark (612) 941-2600; Marshall (612) 559-2211; Schweber (612) 941-5280.  
**MISSOURI:** St. Louis: Arrow/Kierulff (314) 567-6888; Hall-Mark (314) 291-5350; Marshall (314) 291-4650; Schweber (314) 739-0520.  
**NEW HAMPSHIRE:** Arrow/Kierulff (603) 668-8968; Schweber (603) 625-2250.  
**NEW JERSEY:** Arrow/Kierulff (201) 538-0900, (609) 964-8000; GRS Electronics (609) 964-8560; Hall-Mark (201) 575-4415, (201) 882-9770, (609) 235-1900; Marshall (201) 882-0320, (609) 234-9190; Schweber (201) 227-7880.  
**NEW MEXICO:** Arrow/Kierulff (505) 243-4566.  
**NEW YORK:** Long Island: Arrow/Kierulff (516) 231-1009; Hall-Mark (516) 737-0600; Marshall (516) 273-2424; Schweber (516) 334-7474; Zeus (514) 937-7400; Rochester: Arrow/Kierulff (716) 427-0300; Hall-Mark (716) 425-3300; Marshall (716) 235-7620; Schweber (716) 424-2222; Syracuse: Marshall (607) 798-1611.  
**NORTH CAROLINA:** Arrow/Kierulff (919) 876-3132, (919) 725-8711; Hall-Mark (919) 872-0712; Marshall (919) 878-9882; Schweber (919) 876-0000.  
**OHIO:** Cleveland: Arrow/Kierulff (216) 248-3990; Hall-Mark (216) 349-4632; Marshall (216) 248-1788; Schweber (216) 464-2970; Columbus: Hall-Mark (614) 888-3313; Dayton: Arrow/Kierulff (513) 435-5563; Marshall (513) 898-4480; Schweber (513) 439-1800.  
**OKLAHOMA:** Arrow/Kierulff (918) 252-7537; Schweber (918) 622-8003.  
**OREGON:** Arrow/Kierulff (503) 645-6456; Marshall (503) 644-5050; Wyle (503) 640-6000.  
**PENNSYLVANIA:** Arrow/Kierulff (412) 856-7000, (215) 928-1800; GRS Electronics (215) 922-7037; Marshall (412) 963-0441; Schweber (215) 441-0600, (412) 963-6804.  
**TEXAS:** Austin: Arrow/Kierulff (512) 835-4180; Hall-Mark (512) 258-8848; Marshall (512) 837-1991; Schweber (512) 339-0089; Wyle (512) 934-9957; Dallas: Arrow/Kierulff (214) 380-6664; Hall-Mark (214) 553-4300; Marshall (214) 233-5200; Schweber (214) 661-5010; Wyle (214) 235-9953; Zeus (214) 783-7010; El Paso: Marshall (915) 593-0706; Houston: Arrow/Kierulff (713) 530-4700; Hall-Mark (713) 781-6100; Marshall (713) 895-9200; Schweber (713) 784-3600; Wyle (713) 879-9953.  
**UTAH:** Arrow/Kierulff (801) 973-6913; Hall-Mark (801) 972-1008; Marshall (801) 485-1551; Wyle (801) 974-9953.  
**WASHINGTON:** Arrow/Kierulff (206) 575-4420; Marshall (206) 486-5747; Wyle (206) 881-1150.  
**WISCONSIN:** Arrow/Kierulff (414) 792-0150; Hall-Mark (414) 797-7844; Marshall (414) 797-8400; Schweber (414) 784-9020.  
**CANADA:** Calgary: Future (403) 235-5325; Edmonton: Future (403) 438-2858; Montreal: Arrow Canada (514) 735-5511; Future (514) 694-7710; Ottawa: Arrow Canada (613) 226-6903; Future (613) 820-8313; Quebec City: Arrow Canada (418) 871-7500; Toronto: Arrow Canada (416) 672-7569; Future (416) 638-4771; Marshall (416) 674-2161; Vancouver: Arrow Canada (604) 291-2986; Future (604) 294-1166.



# Customer Response Center

TOLL FREE: (800) 232-3200  
 OUTSIDE USA: (214) 995-6611  
 (8:00 a.m. - 5:00 p.m. CST)

# TI Worldwide Sales Offices

**ALABAMA:** Huntsville: 500 Wynn Drive, Suite 514, Huntsville, AL 35805, (205) 837-7530.

**ARIZONA:** Phoenix: 8825 N. 23rd Ave., Phoenix, AZ 85021, (602) 995-1007. Tucson: 818 W. Miracle Mile, Suite 43, Tucson, AZ 85705, (602) 292-2640.

**CALIFORNIA:** Irvine: 17891 Cartwright Dr., Irvine, CA 92714, (714) 660-1200. Roseville: 1 Sierra Gate Plaza, Roseville, CA 95678, (916) 786-9208. San Diego: 4333 View Ridge Ave., Suite 100, San Diego, CA 92123, (619) 278-9601. Santa Clara: 5353 Betsy Ross Dr., Santa Clara, CA 95054, (408) 980-9000. Torrance: 690 Knox St., Torrance, CA 90502, (213) 217-7010. Woodland Hills: 21220 Erwin St., Woodland Hills, CA 91367, (818) 704-7759.

**COLORADO:** Aurora: 1400 S. Potomac Ave., Suite 101, Aurora, CO 80012, (303) 368-8000.

**CONNECTICUT:** Wallingford: 9 Barnes Industrial Park Rd., Barnes Industrial Park, Wallingford, CT 06492, (203) 269-0074.

**FLORIDA:** Altamonte Springs: 370 S. North Lake Blvd., Altamonte Springs, FL 32701, (305) 260-2116; Ft. Lauderdale: 2950 N.W. 62nd St., Ft. Lauderdale, FL 33309, (305) 973-8502; Tampa: 4903 George Rd., Suite 390, Tampa, FL 33634, (813) 885-7411.

**GEORGIA:** Norcross: 5515 Spalding Drive, Norcross, GA 30092, (404) 662-7900.

**ILLINOIS:** Arlington Heights: 515 W. Algonquin, Arlington Heights, IL 60005, (312) 640-2925.

**INDIANA:** Ft. Wayne: 2020 Inwood Dr., Ft. Wayne, IN 46815, (219) 424-5174; Carmel: 550 Congressional Dr., Carmel, IN 46032, (317) 573-6400.

**IOWA:** Cedar Rapids: 373 Collins Rd. NE, Suite 201, Cedar Rapids, IA 52402, (319) 395-9550.

**KANSAS:** Overland Park: 7300 College Blvd., Lightspan Park, Overland Park, KS 66210, (913) 451-4511.

**MARYLAND:** Columbia: 8815 Centre Park Dr., Columbia MD 21045, (301) 964-2003.

**MASSACHUSETTS:** Waltham: 950 Winter St., Waltham, MA 02154, (617) 895-9100.

**MICHIGAN:** Farmington Hills: 33737 W. 12 Mile Rd., Farmington Hills, MI 48018, (313) 553-1559. Grand Rapids: 3075 Orchard Vista Dr. S.E., Grand Rapids, MI 49506, (616) 957-4200.

**MINNESOTA:** Eden Prairie: 11000 W. 78th St., Eden Prairie, MN 55344 (612) 828-9300.

**MISSOURI:** St. Louis: 11816 Borman Drive, St. Louis, MO 63146, (314) 569-7600.

**NEW JERSEY:** Iselin: 485E U.S. Route 1 South, Parkway Towers, Iselin, NJ 08830 (201) 750-1050.

**NEW MEXICO:** Albuquerque: 2820-D Broadbent Pkwy NE, Albuquerque, NM 87107, (505) 345-2555.

**NEW YORK:** East Syracuse: 6365 Collamer Dr., East Syracuse, NY 13057, (315) 463-9291; Melville: 1895 Walt Whitman Rd., P.O. Box 2936, Melville, NY 11747, (516) 454-6600; Pittsford: 2851 Clover St., Pittsford, NY 14534, (716) 385-6770.

**Poughkeepsie:** 395 South Rd., Poughkeepsie, NY 12601, (914) 473-2900.

**NORTH CAROLINA:** Charlotte: 9 Woodlawn Green, Woodlawn Rd., Charlotte, NC 28210, (704) 527-0933; Raleigh: 2809 Highwoods Blvd., Suite 100, Raleigh, NC 27625, (919) 876-2725.

**OHIO:** Beachwood: 23775 Commerce Park Rd., Beachwood, OH 44122, (216) 484-6100; Beavercreek: 4200 Colonel Glenn Hwy, Beavercreek, OH 45431, (513) 427-6200.

**OREGON:** Beaverton: 6700 SW 105th St., Suite 110, Beaverton, OR 97005, (503) 643-6758.

**PENNSYLVANIA:** Blue Bell: 670 SENTRY Pkwy, Blue Bell, PA 19422, (215) 825-9500.

**Puerto Rico:** Hato Rey: Mercanti Plaza Bldg., Suite 505, Hato Rey, PR 00918, (809) 753-8700.

**TENNESSEE:** Johnson City: Erwin Hwy, P.O. Drawer 1255, Johnson City, TN 37605 (615) 461-2192.

**TEXAS:** Austin: 12501 Research Blvd., Austin, TX 78759, (512) 250-7655; Richardson: 1001 E. Campbell Rd., Richardson, TX 75081, (214) 680-5082; Houston: 9100 Southwest Fwy., Suite 250, Houston, TX 77074, (713) 778-6592; San Antonio: 1000 Central Parkway South, San Antonio, TX 78232, (512) 496-1779.

**UTAH:** Murray: 5201 South Green St., Suite 200, Murray, UT 84123, (801) 266-8972.

**WASHINGTON:** Redmond: 5010 148th NE, Bldg B, Suite 107, Redmond, WA 98052, (206) 881-3080.

**WISCONSIN:** Brookfield: 450 N. Sunny Slope, Suite 150, Brookfield, WI 53005, (414) 782-2899.

**CANADA:** Nepean: 3011 Moodie Drive, Mallorn Centre, Nepean, Ontario, Canada, K2H9C4, (613) 726-1970. Richmond Hill: 280 Centre St. E., Richmond Hill L4C1B1, Ontario, Canada (416) 884-9181; St. Laurent: Ville St. Laurent Quebec, 3460 Trans Canada Hwy., St. Laurent, Quebec, Canada H4S1R7, (514) 336-1860.

**ARGENTINA:** Texas Instruments Argentina ViaMonte 1119, 1053 Capital Federal, Buenos Aires, Argentina, 651/748-3699

**AUSTRALIA (& NEW ZEALAND):** Texas Instruments Australia Ltd.: 6-10 Talavera Rd., North Ryde (Sydney), New South Wales, Australia 2113, 2 + 887-1122; 5th Floor, 418 St. Kilda Road, Melbourne, Victoria, Australia 3004, 3 + 267-4677; 171 Philip Highway, Elizabeth, South Australia 5112, 6 + 255-2066.

**AUSTRIA:** Texas Instruments Ges.m.b.H., Industriestrasse B/16, A-2345 Brunn/Gebrige, 2236-846210.

**BELGIUM:** Texas Instruments N.V. Belgium S.A.: 11, Avenue Jules Bondetlaan 11, 1140 Brussels, Belgium, (02) 242-3080.

**BRAZIL:** Texas Instruments Electronicos do Brasil Ltda.: Rua Paes Leme, 524-7 Andar Pinheiros, 05424 So Paulo, Brazil, 0815-6166.

**DENMARK:** Texas Instruments A/S, Mairelandvej 46E, 2730 Herlev, Denmark, 2 - 91 74 00.

**FINLAND:** Texas Instruments Finland OY: Aherantantie 3, P.O. Box 81, ESPOO, Finland, (90) 0-461-422.

**FRANCE:** Texas Instruments France: Paris Office, BP 67 8-10 Avenue Morane-Saulnier, 78141 Velizy-Villacoublay cedex (1) 30 70 1003.

**Germany (Fed. Republic of Germany):** Texas Instruments Deutschland GmbH: Haggertystrasse 1, 8050 Freising, 8161 + 80-4591; Kurfuerstendamm 195/196, 1000 Berlin 15, 30 + 892-7365; Ill. Hagen 43/Kirchstrasse, 19, 4300 Essen, 201-24250; Kirchstrasse 2, 3000 Hannover 51, 511 + 648021; Maybachstrabe 11, 7302 Ostfildern 2-Neeligen, 711 + 34030.

**HONG KONG:** Texas Instruments Hong Kong Ltd., 8th Floor, World Shipping Ctr., 7 Canton Rd., Kowloon, Hong Kong, (852) 3-735123.

**IRELAND:** Texas Instruments (Ireland) Limited: 718 Harcourt Street, Stillorgan, County Dublin, Eire, 1 781677.

**ITALY:** Texas Instruments Italia S.p.A. Divisione Semiconduttori: Viale Europa, 40, 20093 Colonne Monese (Milano), (02) 253001; Via Castello della Magliana, 38, 00148 Roma, (06) 5222851; Via Amendola, 17, 40100 Bologna, (051) 554004.

**JAPAN:** Tokyo Marketing/Sales (Headquarters): Texas Instruments Japan Ltd., MS Shibaura Bldg., 9F, 4-13-23 Shibaura, Minato-ku, Tokyo 108, Japan, 03-769-8700. Texas Instruments Japan Ltd.: Nishio-Iwai Bldg. 5F, 30 Imabashi 3-chome, Higashi-ku, Osaka 541, Japan, 06-294-1881; Daini Toyota West Bldg. 7F, 10-27 Meikei 4-chome, Nakamura-ku, Nagoya 450, 052-553-8891; Daichi Seimei Bldg. 6F, 3-10 Oyama-cho, Kanazawa 920, Ishikawa-ken, 0762-23-5471; Daichi Olympej Tachikawa Bldg. 6F, 1-25-12 Akebono-cho, Tachikawa 190, Tokyo, 0425-27-6426; Matsumoto Showa Bldg. 6F, 2-11 Fukushi 1-chome, Matsumoto 390, Nagano-ken, 0263-33-1060; Yokohama Nishiguchi KN Bldg. 6F, 2-8-4 Kira-Saiwai-cho, Nishi-ku, Yokohama 220, 045-322-6741; Nihon Seimei Kyoto Yasaka Bldg. 5F, 843-2 Higashi Shiohokijohji, Nishiohino in Higashi-ru, Shiohokuji, Shimogyo-ku, Kyoto 600, 075-341-7713; 2597-1, Aza Harudai, Oaza Yasaka, Kitsu-ku, Oita-ken, 0978-6-3211; Miho Plant, 2350 Kihara Mihomura, Inashiki-gun 300-04, Ibaragi-ken, 0298-85-2541.

**KOREA:** Texas Instruments Korea Ltd., 28th Fl., Trade Tower, #159, Samsung-Dong, Kangnam-ku, Seoul, Korea 2 + 551-2810.

**MEXICO:** Texas Instruments de Mexico S.A.: Alfonso Reyes - 115, Col. Hipodromo Condesa, Mexico, D.F., Mexico 06120, 525/525-3860.

**MIDDLE EAST:** Texas Instruments: No. 13, 1st Floor Manana Bldg., Diplomatic Area, P.O. Box 26335, Manama Bahrain, Arabian Gulf, 973 + 274681.

**NETHERLANDS:** Texas Instruments Holland B.V., 19 Hogheijweg, 1100 AZ Amsterdam - Zuidost, Holland 20 + 5602911.

**NORWAY:** Texas Instruments Norway A/S: PB106, Refstad 0585, Oslo 5, Norway, 121 1550590.

**PEOPLES REPUBLIC OF CHINA:** Texas Instruments China Inc., Beijing Representative Office, 7-05 Cite Bldg., 19 Jiaungunwai Dajie, Beijing, China, (861) 5002255, Ext. 3750.

**PHILIPPINES:** Texas Instruments Asia Ltd.: 14th Floor, Ba- Lepanto Bldg., Paseo de Roxas, Makati, Metro Manila, Philippines, 817-60-31.

**PORTUGAL:** Texas Instruments Equipamento Electronico (Portugal), Lda.: Rua Eng. Frederico Ulrich, 2650 Moreira Da Maia, 4470 Maia, Portugal, 2-948-1003.

**SINGAPORE (+ INDIA, INDONESIA, MALAYSIA, THAILAND):** Texas Instruments Singapore (PTE) Ltd., Asia Pacific Division, 101 Thompson Rd. #23-01, United Square, Singapore 1130, 350-8100.

**SPAIN:** Texas Instruments Espana, S.A.: C/ Jose Lazaro Galidano No. 6, Madrid 28036, 1/458-14.58.

**SWEDEN:** Texas Instruments International Trade Corporation (Sverigeaffilaten): S-164-93, Stockholm, Sweden, 8 - 752-5900.

**SWITZERLAND:** Texas Instruments, Inc., Reidstrasse 6, CH-8953 Dietikon (Zuerich) Switzerland, 1-740 2220.

**TAIWAN:** Texas Instruments Supply Co., 9th Floor Bank Tower, 205 Tun Hwa N. Rd., Taipei, Taiwan, Republic of China, 2 + 713-9311.

**UNITED KINGDOM:** Texas Instruments Limited: Manton Lane, Bedford, MK41 7PA, England, 0234 270111.







